

Company Introduction	Section 1	1
Ordering Information	Section 2	2
Performance Data (Standard motor)	Section 3	3
Performance Data (UL motor)	Section 4	4
Performance Graphs	Section 5	5
Motor Dimensions	Section 6	6
Feedback Devices	Section 7	7
Brake Information	Section 8	8
Gearbox Motors	Section 9	9
Fan Blown motors	Section 10	10
Cable Assemblies	Section 11	11
Motor Selection	Section 12	12
Safety & Installation	Section 13	13
Conversion Tables	Section 14	14
Glossary		

Control Techniques Dynamics Limited

CT Dynamics is a British company renowned for its innovations in the industrial servo, aerospace and defence markets. Founded some 40 years ago it has developed a leading position by combining two of the UK's best servo companies: Moore Reed and the Powerotor Division of Evershed and Vignoles. CT Dynamics' experience in the field of servo and rotating components provides a strong base from which to develop cost effective solutions for a spectrum of applications from machine tools, mechanical handling, pick and place machinery - through to specialised mechanisms and actuators for the avionics industry.

CT Dynamics is a member of the Emerson group of the USA. This gives the company access to a vast engineering design resource in the USA, in the UK and in mainland Europe. As a result CT Dynamics offers continuous advances in product range, backed with the expertise and flexibility to meet the demands of your applications - now and in the future.

Introduction

The Unimotor range has been developed following extensive research and testing of thermal dynamic theories and practices.

This range is available in five frame sizes 75; 95; 115; 142 and 190mm, in a unique and instantly recognisable finned design that offers extra strength, rigidity and thermal performance. These are important features for high performance servo systems.

Designed to operate from switched-mode three-phase AC drive outputs with DC link volts up to 750V DC, this range employs a registered UL approved insulation system.

There are four basic motor types, each for different drives.

UM, SL and DM motors are for 400/440V nominal AC drive supply voltage.

EZ motors have identical mechanical construction and feedback options, but support a different winding to suit 220V nominal AC drives such as Unidrive LV and Epsilon /EN drives.

UM, SL and DM Motors

UM Motor

The UM motor has been primarily designed to operate with the Unidrive and Unidrive SP, but can be used with any suitable drive.

Feedback options include resolver; or incremental, sincos single-turn, sincos multi-turn optical encoders.

SL Motor

The SL version is a UM motor fitted with special **SLM technology** electronic feedback that operates with Control Techniques' M'Ax and MultiAx drives. This motor-drive combination offers extremely high resolution, for superb system speed control. High resolution is essential for many system applications where speed and position errors must be miniscule.

The feedback comprises of a special Sincos encoder and **SLM** electronics, both contained within the standard UM outline. The encoder has a memory programmed with all the essential motor characteristics necessary to automatically set all M'Ax parameters, giving an instant 'Plug and Play' capability.

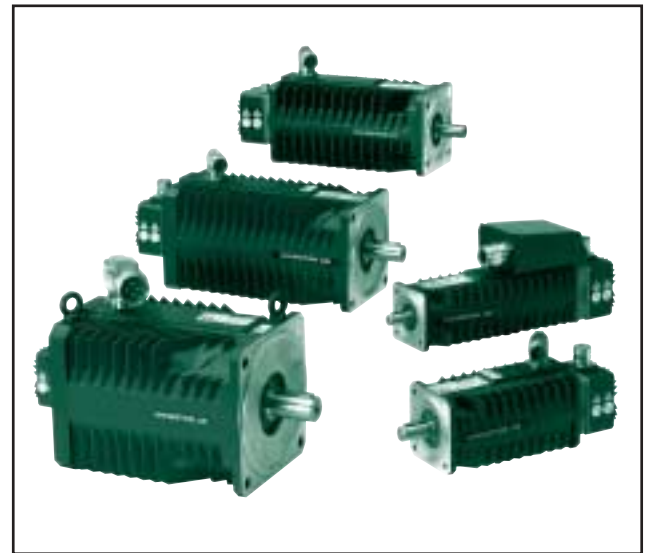

DM Motor

The DM motor is suitable for use with the DigitAx drive. The stator connections to U and V are interchanged to match the DigitAx.

Accessories

Other options

Gearboxes - motor torque can be extended by a good selection of factory-fitted gearboxes, available to order in a wide variety of options.

Forced air-cooling - customer-fitted fan blown boxes specially designed to fit the range of motors, can directly enhance motor performance. (Not suitable for SL).

Custom specials - a range of special adaptations e.g. shaft or feedback type are already designed and may be available where quantities justify.

Cable assemblies - ready made power and signal cables in lengths of 2-100 metres to connect motors to the appropriate drive.

Heat Transfer from Radially Finned Motor Housings

One of the most important features of an electric motor is its rated torque value per unit of motor volume. To maximise this value, the motor surface must lose heat as efficiently as possible. Additionally, servo motors must provide full torque at zero speed. It is not practical to use a shaft mounted fan for cooling so the motor must keep cool through a combination of natural convection, conduction through the front flange, and radiation.

For a motor to give a performance that requires minimal de-rating, it must be designed so that it can be mounted in a number of orientations. The Unimotor's finned design ensures that the motors can be mounted horizontally or vertically without significant effect on heat transfer. CT Dynamics' engineers derived the optimal fin thickness and spacing using a specially designed computational fluid dynamics (CFD) model.

Figure 1

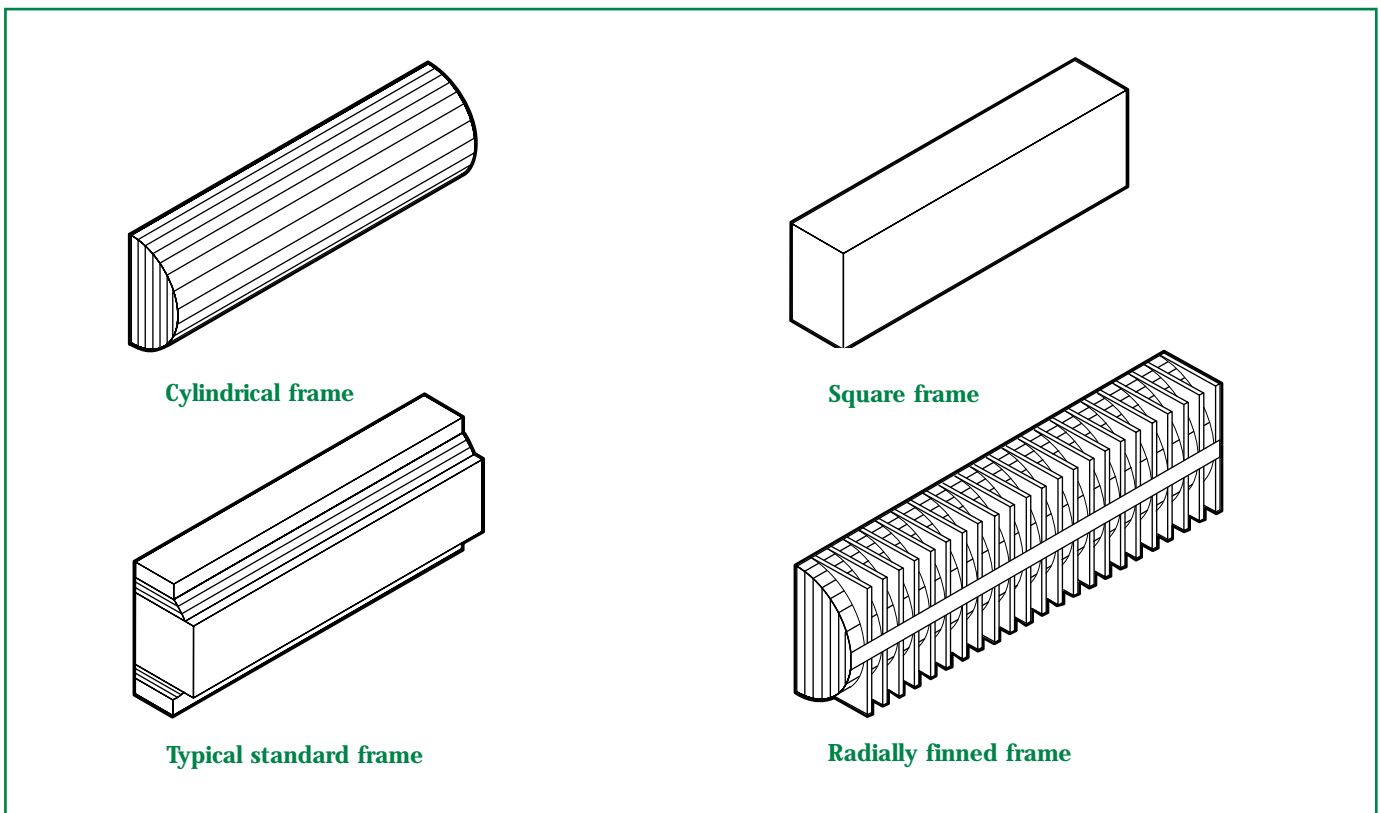

Figure 1. Naturally ventilated motors usually have a relatively smooth frame surface. The frame is cylindrical or square, or a combination of the two. The above illustrations show half cross sections of the various motor types as used in the CFD model

Adding fins to a surface increases the convective cooling - radiators are an everyday example. Axial fins are common in forced ventilated motors. CT Dynamics has taken this concept a stage further to develop the Unimotor range of servo motors.

1

Finned Motors - Designed for Horizontal and Vertical Orientation

Figures 2 and 3 show charts comparing the variation between h_c (heat transfer coefficient for convection) with ΔT for the finned motor design against traditional types. The heat transfer coefficient shows a massive 100% to 200% improvement over conventional housings.

Figure 2
95mm Diameter Frame

Figure 3
190mm Diameter Frame

Figure 4 compares the rated torque of a range of motors with and without radial finning. The figure takes account of the effect of any additional conductive cooling through the front flange and radiation. The additional convection cooling gives a sizeable increase in torque for the finned motor range.

Figure 4
142mm Diameter Frame

Key

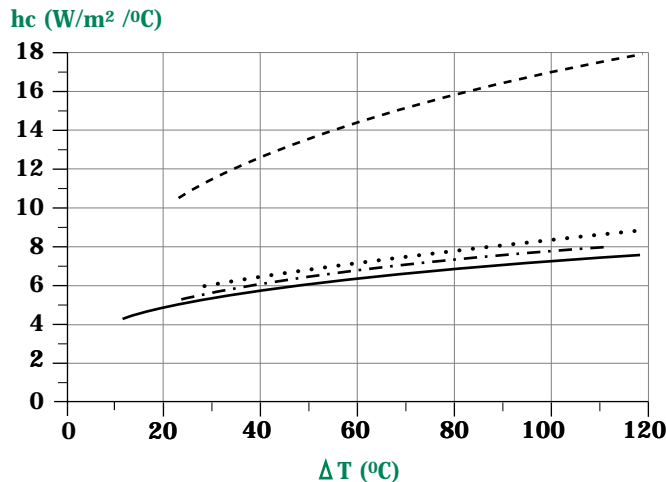
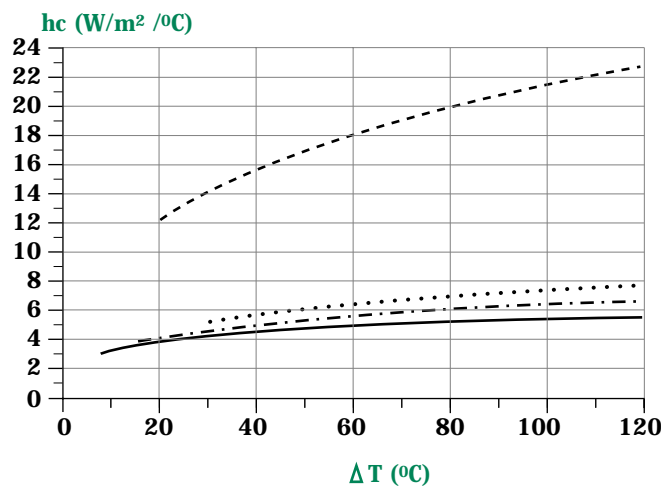
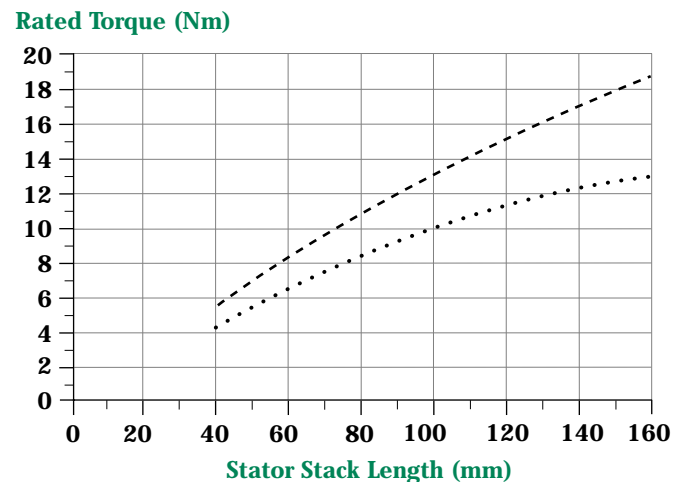
- Fined
- Standard
- . - . - . Square
- Cylindrical

Ordering Information

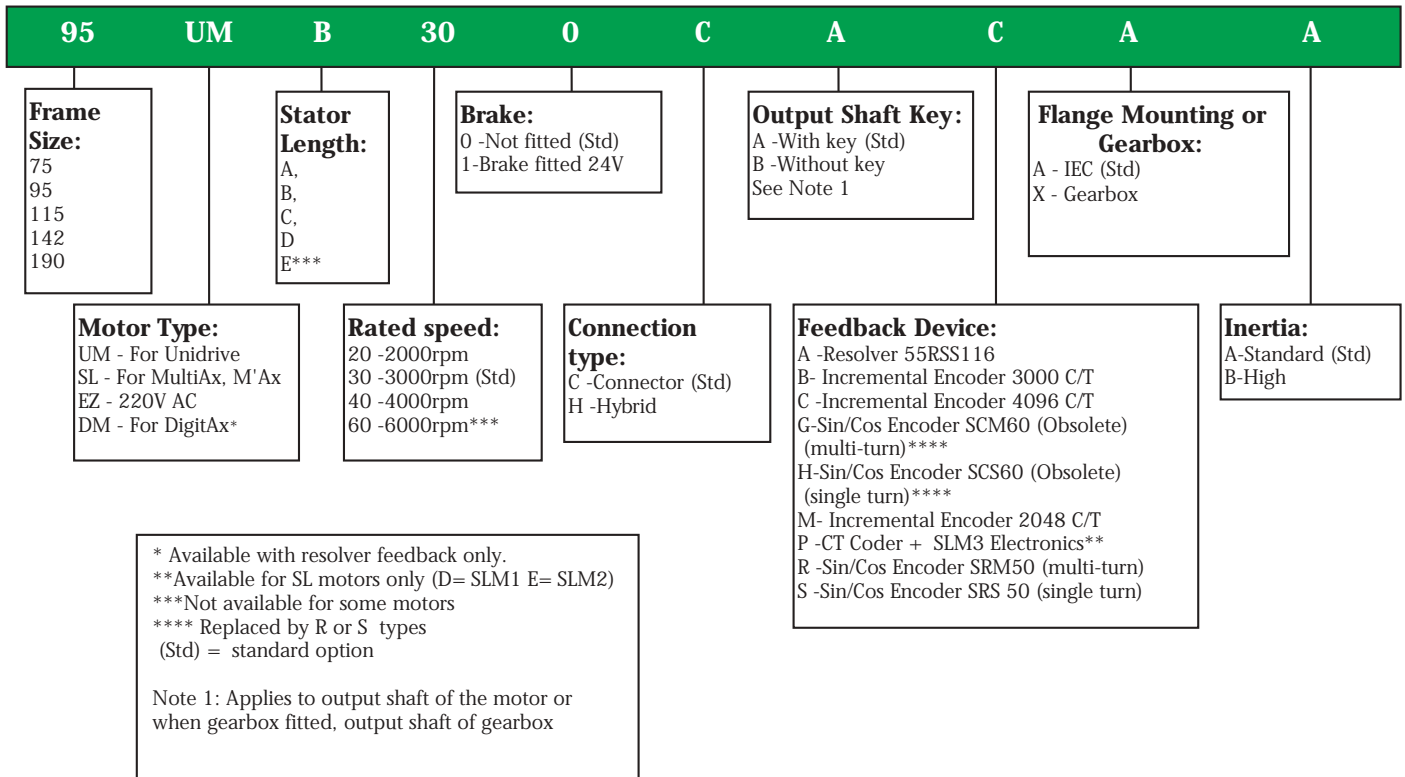
Use the information given in the illustration below to create an order code for the Unimotor. The details in the green band are an example of an order code. CT Dynamics recommends that you order the required mating connectors at the time of placing your order. For further details turn to the cables. See also the grid overleaf, which gives standard and optional features available for each motor. If you are unsure which motor you need see 'Selecting the Correct Motor'.



Standard & Optional Features

This chart shows the standard and optional features available with each motor.

Description	Order Ref.	Refers to	Unimotor Frame Size				
			75	95	115	142	190
Motor Type	UM	For drives 380-480 Vac	●	●	●	●	●
	EZ	For drives 200-240 Vac	■	■	■	■	■
	SL	For M'Ax drives, 380-480 Vac	●	●	●	●	●
	DM* ¹	For Digitax drive, 380-480 Vac	■	■	■	■	■
Stator Length	A		■	■	■	■	■
	B		■	■	■	■	■
	C		■	■	■	■	■
	D		■	■	■	■	■
	E		N/A	■	■	■	N/A
Rated Speed	10	1000 RPM	▲	▲	▲	▲	▲
	20	2000 RPM	■	■	■	■	■
	30	3000 RPM	●	●	●	●	●
	40	4000 RPM	■	■	■	■	▲
	60	6000 RPM	■	■	▲	▲	N/A
Brake	0	Non fitted	●	●	●	●	●
	1	Fitted 24V DC	■	■	■	■	■
Connection Type	C	Connector, rotatable	●	●	●	●	●
	H	Hybrid (Power terminal box)	▲	▲	▲	▲	▲
Output Shaft Key	A	With key	●	●	●	●	●
	B	Without key	■	■	■	■	■
	X	Special shaft or mechanical detail	▲	▲	▲	▲	▲
Feedback Device	C/M	Incremental encoder	●	●	●	●	●
	P	CT Coder (SL only)	■	■	■	■	■
	R	SIN/COS encoder SRM50 (Multi)	■	■	■	■	■
	S	SIN/COS encoder SRS50 (Single)	■	■	■	■	■
	A	Resolver 55RSS 116	■	■	■	■	■
Flange Mounting	A	IEC Flange (no gearbox)	●	●	●	●	●
	X	Gearbox	▲	▲	▲	▲	▲
Inertia	A	Standard	●	●	●	●	●
	B	High	■	■	■	■	■
CTD/IS/2000/01 c  US E215243		UL Insulation system	●	●	●	●	●
		UL recognised motor	■	■	■	■	■

Note:  US E215243 UL recognised motors to be requested at time of order.

Use the codes in the Order Ref. column to build your order code. Choose one reference from each of the description categories.

*¹ The DM Motor type has resolver feedback only.

- - Standard Feature
- - Standard Option
- ▲ - Limited Availability Option
- N/A - Not Available

Specification - UM, EZ, SL, DM (Standard Motors)

Standard motors have UL and CAN/CSA recognised Insulation System to class H, see 'Insulation Class'. The **CTD/IS/2000/01** insulation system number on the motor number plate, together with the  symbol, denotes this. Earlier motors may display this information on a separate label on the rear cover.

If the UL symbol  has "E215243" underneath, then this indicates full motor recognition. (Refer also section 4)

Physical

Insulation Class	Class H, BS EN 60034-1.
Insulation System	USR & CNR Class H Electrical Insulation System designated 'CTD/IS/2000/01'.
Degree of Balance	Rotor balanced to ISO 1940 (BS 6861) G 6.3 (half key convention to ISO 8821).
Temperature Monitoring	PTC thermistor, 170°C switch temperature.
Bearing System	Preloaded ball bearings, metal shielded, high temperature grease.
Electrical Connections	Connector or terminal box for power and brake; connector for feedback devices and thermistor.
Flange Mounting	IEC 60072-1 as standard / NEMA MG-7 optional.
Output Shaft	Plain shaft as standard. Output key is optional (to IEC 60072-1).

Environmental

Ingress Protection	Motor, excluding mounting face, and with mating connectors and cables fitted. Ingress protection : IP65S.
Operating Temperature	Specified performance at 0-40°C ambient.
Storage Temperature	-20°C to 70°C.
Insulation Class	H (180°C) Insulation system. The CTD/IS/2000/01 insulation system number on the motor number plate, together with the  symbol, denotes a UL recognised insulation system, file number E214439.
Temperature Rise (Winding)	For motors with resolver feedback, 125°C over ambient of 40°C Max. For motors with optical feedback, 100°C over ambient of 40°C Max.

Nameplate

Values shown for K_E , K_T and I_0 are nominal values relevant to motors at 20 degrees C. Stall/rated torque ($M_{0/N}$) and power (P_N) are for motors at continuous maximum ratings in a 40 degrees C ambient.



3ø, 8pole, PM Servomotor

- Indicates number of poles. This motor has 8 poles or 4 pole pairs.
- Electrical frequency = (rpm/60) x (number of pole pairs)

190UMD201CBAXA

- Motor type number – ref. Ordering information, Section 2, page 1.

Note that the X indicates that a gearbox is fitted – for gearbox details see gearbox label and section 9 of this manual.

VPWM 380 /480 Vac

- for use with a VPWM (Voltage Pulse Width Modulation) Drive with supply voltage as indicated.

Brake 24 Vdc; 1.1 A

Brake supply requirements

K_E (NOM) 147V/krpm

K_E ac Volts per 1000rpm with motor at 20°C

$M_{0/N}$ 78.0 /60.0 Nm

M_0 (Stall torque) = 78.0Nm; M_N (rated torque @ nominal speed rpm) = 60.0 Nm

P_N 12.6kW

P_N (Power @ nominal speed) = 12.6 kW

K_T 2.40 Nm/A; I_0 32.5A

K_T (Torque Constant) and I_0 (Maximum continuous stall current)

Values shown are for motor magnet temperatures at 20°C.

K_T maybe lower and I_0 higher for typical working conditions.

IP65S

Ingress Protection = IP65S (excludes front shaft seal)

Insulation Class $\text{\textcircled{H}}$

Windings are built to Class H standard (180°C) Motor will have further ambient and Δt restrictions. Refer below.

0-40°C / $\Delta 125^\circ\text{C}$

Ambient temperature range / (delta) winding temperature increase above ambient (at full rating)

T_{CW} 632s

Thermal Time-constant of copper winding with respect to iron laminations.

$n_{N/MAX}$ 2000 /3265 rpm

n_N (nominal speed) = 2000 rpm / n_{MAX} (maximum speed) = 3265 rpm (at maximum drive supply voltage [e.g. 480V and 240V] and no load or low torque)

Note: maximum speed given for motor includes limit of feedback device, but excludes drive limits.

f-b resolver

Feedback Device is a resolver.

Other Devices are as per the following table

Feedback Type	Name
Resolver	"resolver"
Incremental 4096	"4096ppr"
Incremental 1024	"1024ppr"
Incremental 2048	"2048ppr"
CT Coder & SLM3	"SLM3"
Sincos SRM50 1024	"SRM50"
Sincos SRS50 1024	"SRS50"



CE (Conformité Européenne) mark and reference number.

Note: A "Declaration of Incorporation" is contained within the Unimotor Installation Guide that accompanies each motor.

CTD/IS/2000/01

UL and CAN/CSA Recognition marking for the Motor
Insulation system USR and CNR Class 180(H)
electrical insulation system designated
"CTD/IS/2000/01".
The UL list number for this is E214439.

Note: USR - United States Standards Recognized.
CNR - Canadian National Standards Recognized in
accordance with CAN/CSA C22.2 No. 0-M91,
Appendix B.

Performance Definitions (Standard Motor)

A total of four different tables are shown in two groups of two. When referring to tables, please be sure to select the table relevant to requirements.

There are two voltage ranges:

1. UM, SL, DM motors for drives requiring 380-480Vac supply
2. EZ motors for drives requiring 200-240Vac supply

Each of these is sub-divided into two temperature ranges:

- a) $\Delta t = 100^{\circ}\text{C}$ for motors with encoders
- b) $\Delta t = 125^{\circ}\text{C}$ for motors with resolvers

Class H - UL and CSA recognised Insulation System

Class H is a classification of the temperature rating of the motor winding insulation system.

Class H rating has a maximum average winding (copper) wire temperature of 180°C .

All UM, DM, EZ and SL motors have identical insulation systems complying with class H temperature rating irrespective of Δt_{max} .

The Insulation System designated "CTD/IS/200/01" is recognised by the Underwriters Laboratories (UL, USA.) and CSA (Canadian Standards Authority) for voltage and material safety compliance.

Δt temperature

Δt temperature is the temperature difference between the copper wires of the motor winding and the ambient air temperature surrounding the motor.

Δt_{max} temperatures are allocated to CTD motors as follows:

$\Delta t_{\text{max}} = 100^{\circ}\text{C}$, is applicable to all motors fitted with optical encoder feedback due to their maximum operating temperature. $\Delta t_{\text{max}} = 100^{\circ}\text{C}$ is a little lower than a Class F winding rating for 40°C motor ambient air temperature. (Class F has 155°C max average winding temperature)

$\Delta t_{\text{max}} = 125^{\circ}\text{C}$, is applicable to UM and DM motors fitted with resolver feedback.

Rating corresponds to a Class H winding rating of 180°C
For this higher Δt_{max} , a larger winding current is possible, and hence a larger torque rating.

Winding Thermal Time Constant (t_c) seconds

The thermal time constant of the winding with respect to the stator temperature as referenced in the exponential temperature rise given by the formulae: -

Winding temperature at time t seconds = $T_0 + T_1(1 - e^{-t/t_c})$
Where T_0 is initial temperature, T_1 is final winding temperature and t_c = thermal time constant (seconds)

Note that temp = 63.2% of T_1 when $t = t_c$

A thermal protection trip is provided by the drive, based upon calculations using elapsed time, current measurement, and the parameter settings set by the user or directly from the motor map data.

UM, EZ and DM motor windings are ultimately protected by thermistor devices located in the winding overhangs. These thermistors must be connected to the appropriate drive inputs via the motor feedback signal connector. (For pin allocations of signal connectors, refer to section 7)

The improved thermal modelling of the SL motor by the M'Ax and MultiAx drive software renders the need for thermistors to be unnecessary.

Stall Torque

This is the maximum continuous torque within the Continuous Zone at zero or low speeds.

Maximum continuous torque ratings may be intermittently exceeded for short periods provided that winding Δt_{max} temperature is not exceeded.

As with rated torque, the ultimate limiting factor is winding temperature rise:

Δt_{max} = maximum winding temperature rise above ambient.
= 100°C or 125°C according to motor type

For stall conditions, the heating occurs in the copper windings due to I²R losses, plus some ac ripple current loss due to the drive switching frequency.

Peak Torque

Peak torque is the maximum torque that can be safely applied to the motor at any time, provided that the maximum Δt temperature limit is never exceeded.

Rated Torque

This is the continuously rated torque at full rated speed.

This will be less than stall torque, because as the motor turns, magnetic lines of flux move through the stator laminations creating additional iron losses that increase with speed, also, to a lesser extent, viscous friction losses are added.

Rated Speed

This is the normal maximum speed for the motor.

The motor speed can be controlled to any speed subject to voltage limits and drive constraints as shown by the Intermittent Zone of the graphs. (see "Speed Limit")

A higher speed motor has fewer winding turns, but requires a higher current to produce the same torque as a similar lower speed motor.

The induced motor voltage at rated speed and no load must be sufficiently less than the supply voltage, to allow for additional voltage across the resistance and inductance of windings as torque (approx = current) is applied.

Rated Power

This is the product of rated speed (radians/sec) and torque (Nm) expressed in Watts (W).

Twice the speed gives twice the output power at the same torque level.

Motor Efficiency

Defined as (power out) / (power in) and expressed as a percentage, motor efficiencies are typically > 95% at full power.

At no load and low torque levels, drive waveforms may distort due to poor resolution at low current, causing iron loss, low efficiency and an unexpected motor temperature rise.

Voltage Constant (Ke) Volt (rms)/krpm

This is the phase-phase rms voltage generated at the stator when the shaft is back-driven at 1000rpm with rotor at 20°C.

Torque Constant (Kt) Nm/A(rms)

As for a brushed motor, a brushless commutating motor delivers torque proportional to current, such that torque = Kt x current. Where Kt = 0.0165 x Ke (at 20°C).

Magnets used on all motors are affected by temperature, such that Kt and Ke reduce with increasing temperature of magnets. Kt and Ke reduce by 0.1% / °C for all 75 – 142 motors; and by 0.035% / °C for 190 motors. Temperature of magnets may be assumed to reach 87% of winding temperature.

Stall Current A rms

Stall Current = (Stall Torque) / Kt

Motor label and tables quote stall current for motor windings at 20°C.

Rated Current A rms

Rated Current = (Rated Torque) / Kt

Pole Pairs

75–142 motors have 6 poles = 3 pole pairs

190 motors have 8 poles = 4 pole pairs

UM & SL servo motor technical specifications		For 3 Phase VPWM Drives 380 - 480Vrms																							
		75				95				115				142				190							
All Speeds		A	B	C	D	A	B	C	D	E	A	B	C	D	E	A	B	C	D	E	A	B	C	D	
Continuous Stall Torque (Nm)		1.2	2.2	3.1	3.9	2.3	4.3	5.9	7.5	9.0	3.5	6.6	9.4	12.4	15.3	6.3	10.8	15.3	19.8	23.4	21.8	41.1	58.7	73.2	
Peak Torque nominal (Nm)		3.6	6.6	9.3	11.7	6.9	12.9	17.7	22.5	27.0	10.5	19.8	28.2	37.2	45.9	18.9	32.4	45.9	59.4	70.2	65.4	123	176	219	
High Inertia (kgcm ²)		1.2	1.6	2.1	2.5	3.5	4.5	5.6	6.7	7.8	9.7	12.0	14.3	16.6	18.8	21.6	28.0	34.3	40.7	47.0	93.5	141	188	235	
Standard Inertia (kgcm ²)		0.6	1.0	1.5	1.9	1.4	2.5	3.6	4.7	5.8	3.2	5.5	7.8	10.0	12.3	7.8	14.1	20.5	26.8	33.1	50.0	97.0	144	191	
Weight (kg)		3.0	3.7	4.4	5.1	5.0	6.1	7.2	8.3	9.5	6.5	8.2	9.9	11.6	13.2	10.9	13.2	15.5	17.8	20.5	26.0	33.0	40.0	48.0	
Winding Thermal Time Const.(sec)		81	74	94	100	172	168	183	221	228	175	185	198	217	241	213	217	275	301	365	240	242	319	632	
Maximum Cogging (Nmm)		0.02	0.03	0.04	0.05	0.03	0.06	0.08	0.10	0.13	0.06	0.10	0.14	0.18	0.21	0.09	0.16	0.23	0.30	0.35	0.30	0.54	0.72	0.99	
Rated Speed 2000 (rpm)		Kt (Nm/A) 2.40																							
		Ke (V/krpm) 147																							
Rated Torque (Nm)		1.1	2.1	3.0	3.8	2.2	4.0	5.5	6.9	8.2	3.2	6.1	8.7	10.8	14.0	5.9	10.3	14.6	18.4	21.3	20.0	36.9	50.4	54.7	
Stall Current (A)		0.5	1.0	1.3	1.7	1.0	1.8	2.5	3.2	3.8	1.5	2.8	4.0	5.2	6.4	2.7	4.5	6.4	8.3	9.8	9.1	17.2	24.5	30.5	
Rated Power(kW)		0.23	0.44	0.63	0.80	0.46	0.84	1.15	1.45	1.72	0.67	1.28	1.82	2.26	2.93	1.24	2.16	3.06	3.85	4.46	4.19	7.73	10.6	11.5	
R (ph-ph) (Ohms)		144	48.2	25.0	15.7	59.0	17.0	9.90	6.00	4.30	27.8	8.55	4.55	2.96	2.17	12.5	3.60	2.10	1.35	0.98	1.80	0.56	0.33	0.23	
L (ph-ph) (mH)		214	99.2	59.2	44.7	131	54.5	36.5	25.6	18.9	94.6	40.5	25.7	18.6	14.7	56.0	29.8	18.7	13.6	10.7	28.1	13.0	8.90	6.30	
Rated Speed 3000 (rpm)		Kt (Nm/A) 1.6																							
		Ke (V/krpm) 98.0																							
Rated Torque (Nm)		1.1	2.0	2.8	3.5	2.0	3.9	5.4	6.8	8.1	3.0	5.5	8.1	10.4	12.6	5.4	9.0	12.2	15.8	18.0	19.2	33.0	35.0	36.8	
Stall Current (A)		0.8	1.4	2.0	2.5	1.5	2.7	3.7	4.7	5.7	2.2	4.2	5.9	7.8	9.6	4.0	6.8	9.6	12.4	14.7	13.7	25.7	36.7	45.8	
Rated Power(kW)		0.35	0.63	0.88	1.10	0.63	1.23	1.70	2.14	2.54	0.94	1.73	2.54	3.27	3.96	1.70	2.83	3.83	4.96	5.65	6.03	10.4	11.0	11.6	
R (ph-ph) (Ohms)		60.8	20.1	10.5	7.5	24.5	6.80	4.00	2.50	2.00	12.6	3.86	2.02	1.40	1.10	5.63	1.72	0.94	0.61	0.44	0.79	0.30	0.14	0.09	
L (ph-ph) (mH)		98.4	41.8	27.6	19.7	57.9	24.3	15.5	10.9	8.50	43.1	18.6	11.4	8.60	7.40	31.0	13.3	8.30	6.10	4.80	13.2	6.11	3.60	2.46	
Rated Speed 4000 (rpm)		Kt (Nm/A) 1.20																							
		Ke (V/krpm) 73.5																							
Rated Torque (Nm)		1.0	1.7	2.3	2.9	1.8	3.0	4.0	4.9	5.7	2.5	4.7	6.3	7.5	8.7	3.6	7.0	8.9	10.7	12.2	12.2	21.1	22.2	N/A	
Stall Current (A)		1.0	1.9	2.6	3.3	2.0	3.6	5.0	6.3	7.5	3.0	5.5	7.9	10.4	12.8	5.3	9.0	12.8	16.5	19.5	19.5	35.0	36.7	N/A	
Rated Power(kW)		0.42	0.71	0.96	1.21	0.75	1.26	1.68	2.05	2.39	1.05	1.97	2.64	3.14	3.64	1.51	2.93	3.73	4.48	5.11	5.11	9.0	9.6	N/A	
R (ph-ph) (Ohms)		36.8	10.5	6.30	4.20	12.7	4.08	2.10	1.50	1.03	6.91	2.14	1.16	0.73	0.57	3.12	1.00	0.53	0.35	0.24	0.24	0.30	0.14	0.09	
L (ph-ph) (mH)		54.9	24.8	14.9	10.8	31.5	13.6	8.50	6.30	4.80	23.5	10.2	6.60	4.70	3.90	17.6	7.50	4.70	3.60	2.70	2.70	4.70	4.70	N/A	
Rated Speed 6000 (rpm)		Kt (Nm/A) 0.80																							
		Ke (V/krpm) 49.0																							
Rated Torque (Nm)		0.9	1.6	2.1	2.6	1.3	2.1	2.8	3.3	3.7	2.2	4.0	5.1	6.1	7.1	2.9	4.5	5.1	6.1	7.1	7.1	12.2	12.2	N/A	
Stall Current (A)		1.5	2.8	3.9	4.9	2.9	5.4	7.4	9.4	11.3	4.4	8.3	11.8	14.4	17.1	7.9	13.5	15.5	18.6	21.7	21.7	36.7	36.7	N/A	
Rated Power(kW)		0.57	1.01	1.32	1.63	0.82	1.32	1.76	2.07	2.32	1.38	2.51	3.20	3.81	4.41	1.82	2.83	3.63	4.43	5.11	5.11	9.0	9.6	N/A	
R (ph-ph) (Ohms)		15.0	5.00	2.66	1.90	5.45	1.82	1.05	0.62	0.48	3.10	0.97	0.50	0.30	0.20	1.42	0.46	0.26	0.16	0.10	0.10	0.14	0.14	N/A	
L (ph-ph) (mH)		24.0	10.6	6.80	4.80	14.1	6.00	3.80	2.70	2.10	15.5	4.81	2.94	2.04	1.64	7.72	3.44	2.24	1.64	1.24	1.24	2.04	2.04	N/A	

All data subject to +/-10% tolerance

Stall torque; rated torque and power relate to maximum continuous operation in a 40 °C ambient

Unimotors with Encoder Feedback
Δt = 100 degC

▲ Consult factory

▲ Not available

The information contained in this specification is for guidance only and does not form part of any contract.
CTD Dynamics Limited have an ongoing process of development and reserve the right to change the specification without notice.

UM & DM servo motor technical specifications

For 3 Phase VPWM Drives 380 - 480Vrms
v.18M (last updated: 11/2013)

Unimotors with Resolver Feedback
 $\Delta t = 125 \text{ degC}$

Stall torque, rated torque and power relate to maximum continuous operation in a 40 °C ambient

All data subject to +/-10% tolerance

All Speeds	75				95				115				142				190					
	A	B	C	D	A	B	C	D	A	B	C	D	A	B	C	D	A	B	C	D		
Continuous Stall Torque (Nm)	1.3	2.4	3.4	4.4	2.5	4.6	6.5	8.3	10.0	4.0	7.3	10.5	13.9	17.6	7.3	12.5	17.7	22.9	27.0	43.2	62.8	78.0
Peak Torque nominal (Nm)	3.6	6.6	9.3	11.7	6.9	12.9	17.7	22.5	27.0	10.5	19.8	28.2	37.2	45.9	18.9	32.4	45.9	59.4	70.2	123	176	219
High Inertia (kgcm ²)	1.2	1.6	2.1	2.5	3.5	4.5	5.6	6.7	7.8	9.7	12.0	14.3	16.6	18.8	21.6	28.0	34.3	40.7	47.0	93.5	141	188
Standard Inertia (kgcm ²)	0.6	1.0	1.5	1.9	1.4	2.5	3.6	4.7	5.8	3.2	5.5	7.8	10.0	12.3	7.8	14.1	20.5	26.8	33.1	50.0	97.0	144
Weight (kg)	3.0	3.7	4.4	5.1	5.0	6.1	7.2	8.3	9.5	6.5	8.2	9.9	11.6	13.2	10.9	13.2	15.5	17.8	20.5	26.0	33.0	40.0
Winding Thermal Time Const.(sec)	81	74	94	100	172	168	183	221	228	175	185	198	217	241	213	217	275	301	365	240	242	319
Maximum Cogging (Nmm)	0.02	0.03	0.04	0.05	0.03	0.06	0.08	0.10	0.13	0.06	0.10	0.14	0.18	0.21	0.09	0.16	0.23	0.30	0.35	0.30	0.54	0.72
Rated Speed 2000 (rpm)																						
Kt (Nm/A) 2.40																						
Ke (V/krpm) 147																						
Rated Torque (Nm)	1.2	2.3	3.3	4.2	2.3	4.3	6.0	7.6	9.1	3.7	6.8	9.8	12.3	16.6	6.8	12.0	17.0	21.4	24.9	20.8	39.0	53.0
Stall Current (A)	0.6	1.0	1.5	1.9	1.1	2.0	2.8	3.5	4.2	1.7	3.1	4.4	5.8	7.4	3.1	5.3	7.4	9.6	11.3	9.7	18.0	26.2
Rated Power(kW)	0.25	0.48	0.69	0.88	0.48	0.90	1.26	1.59	1.91	0.77	1.42	2.05	2.58	3.48	1.42	2.51	3.56	4.48	5.22	4.36	8.17	11.1
R (ph-ph) (Ohms)	144	48.2	25.0	15.7	59.0	17.0	9.90	6.00	4.30	27.8	8.55	4.55	2.96	2.17	12.5	3.60	2.10	1.35	0.98	1.80	0.56	0.33
L (ph-ph) (mH)	214	99.2	59.2	44.7	131	54.5	36.5	25.6	18.9	94.6	40.5	25.7	18.6	14.7	58.0	29.8	18.7	13.6	10.7	28.1	13.0	8.90
Rated Speed 3000 (rpm)																						
Kt (Nm/A) 1.60																						
Ke (V/krpm) 98.0																						
Rated Torque (Nm)	1.2	2.2	3.1	3.9	2.2	4.2	5.9	7.5	9.0	3.3	6.2	9.2	11.9	14.7	6.3	10.5	14.2	18.4	21.0	20.1	36.2	48.8
Stall Current (A)	0.9	1.5	2.2	2.8	1.6	2.9	4.1	5.2	6.3	2.5	4.6	6.6	8.7	11.0	4.6	7.9	11.1	14.4	16.9	14.5	27.0	39.3
Rated Power(kW)	0.38	0.69	0.97	1.23	0.69	1.32	1.85	2.36	2.83	1.04	1.95	2.89	3.74	4.62	1.98	3.30	4.46	5.78	6.60	6.31	11.4	12.0
R (ph-ph) (Ohms)	60.8	20.1	10.5	7.50	24.5	6.80	4.00	2.50	2.00	12.6	3.86	2.02	1.40	1.10	5.63	1.72	0.94	0.61	0.44	0.79	0.30	0.14
L (ph-ph) (mH)	98.4	41.8	27.6	19.7	57.9	24.3	15.5	10.9	8.50	43.1	18.6	11.4	8.60	7.40	31.0	13.3	8.30	6.10	4.80	13.2	6.11	3.60
Rated Speed 4000 (rpm)																						
Kt (Nm/A) 1.20																						
Ke (V/krpm) 73.5																						
Rated Torque (Nm)	1.1	1.9	2.6	3.3	2.0	3.2	4.4	5.5	6.6	2.9	5.4	7.3	8.6	10.0	4.2	8.2	10.4	12.5	14.2	13.2	24.5	32.5
Stall Current (A)	1.1	2.0	2.9	3.7	2.1	3.9	5.5	7.0	8.4	3.4	6.1	8.8	11.6	14.7	6.1	10.5	14.8	19.1	21.0	20.1	36.2	48.8
Rated Power(kW)	0.46	0.80	1.09	1.38	0.84	1.34	1.84	2.30	2.76	1.21	2.26	3.06	3.60	4.19	1.76	3.43	4.36	5.24	6.00	6.31	11.4	12.0
R (ph-ph) (Ohms)	36.8	10.5	6.30	4.20	12.7	4.08	2.10	1.50	1.03	6.91	2.14	1.16	0.73	0.57	3.12	1.00	0.53	0.35	0.25	0.79	0.30	0.14
L (ph-ph) (mH)	54.9	24.8	14.9	10.8	31.5	13.6	8.50	6.30	4.80	23.5	10.2	6.60	4.70	3.90	17.6	7.50	4.70	3.60	2.80	13.2	6.11	3.60
Rated Speed 6000 (rpm)																						
Kt (Nm/A) 0.80																						
Ke (V/krpm) 49.0																						
Rated Torque (Nm)	1.0	1.8	2.4	3.0	1.7	2.7	3.7	4.8	5.9	2.7	4.7	6.1	7.1	8.1	3.6	5.7	7.1	8.1	9.1	8.1	15.1	19.1
Stall Current (A)	1.7	3.0	4.3	5.5	3.2	5.8	8.2	10.4	12.5	5.0	9.2	13.2	16.1	19.1	9.2	15.7	19.1	22.1	25.1	22.1	40.1	53.1
Rated Power(kW)	0.63	1.13	1.51	1.88	1.07	1.70	2.32	3.02	3.71	1.70	2.95	3.83	4.62	5.41	2.26	3.58	4.36	5.24	6.00	6.31	11.4	12.0
R (ph-ph) (Ohms)	15.0	5.00	2.66	1.90	5.45	1.82	1.05	0.62	0.48	3.10	0.97	0.50	0.35	0.25	1.42	0.46	0.35	0.25	0.18	0.79	0.30	0.14
L (ph-ph) (mH)	24.0	10.6	6.80	4.80	14.1	6.00	3.80	2.70	2.10	15.5	4.81	2.94	2.10	1.70	7.72	3.44	2.80	2.10	1.60	13.2	6.11	3.60

The information contained in this specification is for guidance only and does not form part of any contract.

CTDynamics Limited have an ongoing process of development and reserve the right to change the specification without notice.

N/A Not available ▲ Consult factory

Motor Frame Size (mm)		75					95					115					142					190				
		A	B	C	D	E	A	B	C	D	E	A	B	C	D	E	A	B	C	D	E	A	B	C	D	E
Unimotors with Encoder Feedback $\Delta t = 100 \text{ degC}$		Stall torque; rated torque and power relate to maximum continuous operation in a 40 °C ambient																								
All Speeds		All data subject to $\pm 10\%$ tolerance																								
Continuous Stall Torque (Nm)		1.2	2.2	3.1	3.9	4.3	5.9	7.5	9.0	9.4	12.4	15.3	6.3	10.8	15.3	19.8	23.4	21.8	41.1	58.7	73.2					
Peak Torque nominal (Nm)		3.6	6.6	9.3	11.7	6.9	12.9	17.7	22.5	27.0	10.5	18.9	21.6	28.0	34.3	40.7	47.0	65.4	123	176	219					
High Inertia (kgcm^2)		1.2	1.6	2.1	2.5	3.5	4.5	5.6	6.7	7.8	9.7	12.0	14.3	16.6	18.8	21.6	26.8	33.1	50.0	97.0	144					
Standard Inertia (kgcm^2)		0.6	1.0	1.5	1.9	1.4	2.5	3.6	4.7	5.8	3.2	5.5	7.8	10.0	12.3	14.1	20.5	26.8	33.1	50.0	97.0					
Weight (kg)		3.0	3.7	4.4	5.1	5.0	6.1	7.2	8.3	9.5	6.5	8.2	9.9	11.6	13.2	15.5	17.8	20.5	33.0	40.0	48.0					
Winding Thermal Time Const.(sec)		81	74	94	100	172	168	183	221	228	175	185	198	217	241	213	217	275	301	365	240					
Maximum Cogging (Nm)		0.02	0.03	0.04	0.05	0.03	0.06	0.08	0.10	0.13	0.06	0.10	0.14	0.18	0.21	0.09	0.16	0.23	0.30	0.35	0.30					
Rated Speed 2000 (rpm)		Kt (Nm/A) 1.40 Ke (V/krpm) 85.5																								
Rated Torque (Nm)		1.1	2.1	3.0	3.8	2.2	4.0	5.5	6.9	8.2	3.2	6.1	8.7	10.8	14.0	5.9	10.3	14.6	20.0	36.9	50.4					
Continuous Stall Current (A)		0.9	1.6	2.3	2.8	1.7	3.1	4.3	5.4	6.5	2.6	4.8	6.8	8.9	11.0	4.6	7.8	11.0	15.7	29.5	42.1					
Rated Power (kW)		0.23	0.44	0.63	0.80	0.46	0.84	1.15	1.45	1.72	0.67	1.28	1.82	2.26	2.93	1.24	2.16	3.06	4.19	7.73	10.6					
R (ph-ph) (Ohms)		45.8	15.3	8.52	5.72	19.4	6.24	3.16	2.31	1.71	9.09	2.83	1.51	0.99	0.82	4.28	1.33	0.76	0.45	0.32	0.50					
L (ph-ph) (mH)		98.8	43.4	27.9	20.2	59.2	25.8	16.0	12.6	10.1	47.3	20.6	13.1	9.54	7.86	33.7	15.1	10.3	6.96	5.58	7.98					
Rated Speed 3000 (rpm)		Kt (Nm/A) 0.93 Ke (V/krpm) 57.0																								
Rated Torque (Nm)		1.1	2.0	2.8	3.5	2.0	3.9	5.4	6.8	8.1	3.0	5.5	8.1	10.4	12.6	5.4	9.0	12.2	15.8	33.0	N/A					
Continuous Stall Current (A)		1.3	2.4	3.4	4.2	2.5	4.7	6.4	8.1	9.7	3.8	7.1	10.2	13.4	16.5	6.8	11.7	16.5	21.3	44.2	N/A					
Rated Power (kW)		0.35	0.63	0.88	1.10	0.63	1.23	1.70	2.14	2.54	0.94	1.73	2.54	3.27	3.96	1.70	2.83	3.83	4.96	6.03	10.4					
R (ph-ph) (Ohms)		18.9	6.26	3.50	2.38	8.03	2.68	1.57	1.03	0.77	4.01	1.30	0.73	0.47	0.37	1.90	0.59	0.31	0.20	0.25	0.08					
L (ph-ph) (mH)		42.5	18.4	11.9	8.82	25.6	12.0	7.91	5.60	4.65	20.1	9.16	6.07	4.26	3.49	15.0	6.85	4.20	1.94	3.98	1.87					
Rated Speed 4000 (rpm)		Kt (Nm/A) 0.72 Ke (V/krpm) 44.0																								
Rated Torque (Nm)		1.0	1.7	2.3	2.9	1.8	3.0	4.0	4.9	5.7	2.5	4.7	7.5	9.4	11.6	3.6	7.0	9.4	12.2	25.5	N/A					
Continuous Stall Current (A)		1.7	3.1	4.4	5.5	3.3	6.0	8.3	10.5	12.6	4.9	9.2	13.1	17.3	21.3	8.8	15.1	20.3	26.8	54.2	N/A					
Rated Power (kW)		0.42	0.71	0.96	1.21	0.75	1.26	1.68	2.05	2.39	1.05	1.97	2.64	3.14	3.83	1.51	2.93	3.96	5.19	6.03	10.4					
R (ph-ph) (Ohms)		10.2	3.39	1.92	1.48	5.15	1.64	0.92	0.62	0.43	2.62	0.82	0.44	0.29	0.20	1.20	0.36	0.20	0.15	0.25	0.08					
L (ph-ph) (mH)		24.6	10.8	7.14	5.42	15.5	6.77	4.61	3.46	2.54	12.6	5.48	3.57	2.53	1.94	9.45	4.08	2.60	1.87	3.98	1.87					
Rated Speed 6000 (rpm)		Kt (Nm/A) 0.47 Ke (V/krpm) 28.5																								
Rated Torque (Nm)		0.9	1.6	2.1	2.6	1.3	2.1	2.8	3.3	4.0	2.2	4.0	6.3	7.5	9.4	2.9	5.4	7.2	9.4	19.2	N/A					
Continuous Stall Current (A)		2.6	4.8	6.7	8.4	5.0	9.3	12.7	16.2	20.7	7.6	14.2	21.3	28.0	35.4	13.6	25.1	33.1	42.1	84.2	N/A					
Rated Power (kW)		0.57	1.01	1.32	1.63	0.82	1.32	1.76	2.07	2.41	1.38	2.51	3.83	4.59	5.62	1.82	3.46	4.61	5.96	7.41	12.6					
R (ph-ph) (Ohms)		4.49	1.49	0.95	0.65	2.01	0.67	0.35	0.26	0.19	0.96	0.30	0.16	0.10	0.07	0.49	0.16	0.10	0.07	0.12	0.04					
L (ph-ph) (mH)		10.7	4.73	3.10	2.33	6.41	3.01	1.77	1.40	1.01	4.80	2.09	1.38	0.94	0.70	3.96	1.64	1.01	0.64	1.01	0.40					

N/A Not available
▲ Consult factory
The information contained in this specification is for guidance only and does not form part of any contract.
CTD Dynamics Limited have an ongoing process of development and reserve the right to change the specification without notice.

EZ servo motor technical specifications		For 3 Phase VPWM Drives 200 - 240Vrms																																						
		75					95					115					142					190																		
All Speeds		Frame Length					A					B					C					D																		
Unimotors with Resolver Feedback $\Delta t = 125 \text{ degC}$		Stall torque; rated torque and power relate to maximum continuous operation in a 40 °C ambient All data subject to +/-10% tolerance																																						
Continuous Stall Torque (Nm)		1.3	2.4	3.4	4.4	4.4	2.5	4.6	6.5	8.3	10.0	4.0	7.3	10.5	13.9	17.6	7.3	12.5	17.7	22.9	27.0	32.2	37.2	45.9	27.0	32.2	37.2	45.9	27.0	32.2	37.2	45.9	27.0	32.2	37.2	45.9				
Peak Torque nominal (Nm)		3.6	6.6	9.3	11.7	6.9	12.9	17.7	22.5	27.0	10.5	19.8	28.2	37.2	45.9	18.9	32.4	45.9	59.4	70.2	59.4	70.2	85.4	123	176	219	235	235	235	235	235	235	235	235	235	235				
High Inertia (kg $\cdot\text{cm}^2$)		1.2	1.6	2.1	2.5	3.5	4.5	5.6	6.7	7.8	9.7	12.0	14.3	16.6	18.8	21.6	28.0	34.3	40.7	47.0	47.0	50.0	50.0	50.0	50.0	50.0	50.0	50.0	50.0	50.0	50.0	50.0	50.0	50.0	50.0	50.0	50.0			
Standard Inertia (kg $\cdot\text{cm}^2$)		0.6	1.0	1.5	1.9	1.4	2.5	3.6	4.7	5.8	3.2	5.5	7.8	10.0	12.3	7.8	14.1	20.5	26.8	33.1	33.1	33.1	33.1	33.1	33.1	33.1	33.1	33.1	33.1	33.1	33.1	33.1	33.1	33.1	33.1	33.1	33.1	33.1		
Weight (kg)		3.0	3.7	4.4	5.1	5.0	6.1	7.2	8.3	9.5	6.5	8.2	9.9	11.6	13.2	10.9	13.2	15.5	17.8	20.5	20.5	20.5	20.5	20.5	20.5	20.5	20.5	20.5	20.5	20.5	20.5	20.5	20.5	20.5	20.5	20.5	20.5	20.5	20.5	
Winding Thermal Time Const.(sec)		81	74	94	100	172	168	183	221	228	175	185	198	217	241	213	217	275	301	365	365	365	365	365	365	365	365	365	365	365	365	365	365	365	365	365	365	365	365	
Maximum Cogging (Nm)		0.02	0.03	0.04	0.05	0.04	0.03	0.06	0.08	0.10	0.13	0.06	0.10	0.14	0.18	0.21	0.09	0.16	0.23	0.30	0.35	0.35	0.35	0.35	0.35	0.35	0.35	0.35	0.35	0.35	0.35	0.35	0.35	0.35	0.35	0.35	0.35	0.35	0.35	
Rated Speed 2000 (rpm)		Kt (Nm/A) 1.40 Ke (V/krpm) 85.5																																						
Rated Torque (Nm)		1.2	2.3	3.3	4.2	2.3	4.3	6.0	7.6	9.1	6.8	9.8	12.3	16.6	6.8	12.0	17.0	21.4	24.9	24.9	24.9	24.9	24.9	24.9	24.9	24.9	24.9	24.9	24.9	24.9	24.9	24.9	24.9	24.9	24.9	24.9	24.9	24.9		
Stall Current (A)		1.0	1.8	2.5	3.2	1.8	3.3	4.7	6.0	7.2	2.9	5.3	7.6	10.0	12.7	5.3	9.0	12.7	16.5	19.4	19.4	19.4	19.4	19.4	19.4	19.4	19.4	19.4	19.4	19.4	19.4	19.4	19.4	19.4	19.4	19.4	19.4	19.4	19.4	
Rated Power (kW)		0.25	0.48	0.69	0.88	0.48	0.90	1.26	1.59	1.91	0.77	1.42	2.05	2.58	3.48	1.42	2.51	3.56	4.48	5.22	5.22	5.22	5.22	5.22	5.22	5.22	5.22	5.22	5.22	5.22	5.22	5.22	5.22	5.22	5.22	5.22	5.22	5.22	5.22	
R (ph-ph) (Ohms)		45.8	15.3	8.52	5.72	19.4	6.2	3.16	2.31	1.71	9.09	2.83	1.51	0.99	0.82	4.28	1.33	0.76	0.45	0.32	0.32	0.32	0.32	0.32	0.32	0.32	0.32	0.32	0.32	0.32	0.32	0.32	0.32	0.32	0.32	0.32	0.32	0.32	0.32	
L (ph-ph) (mH)		98.8	43.4	27.9	20.2	59.2	25.8	16.0	12.6	10.1	47.3	20.6	13.1	9.54	7.86	33.7	15.1	10.30	6.96	5.58	5.58	5.58	5.58	5.58	5.58	5.58	5.58	5.58	5.58	5.58	5.58	5.58	5.58	5.58	5.58	5.58	5.58	5.58	5.58	
Rated Speed 3000 (rpm)		Kt (Nm/A) 0.93 Ke (V/krpm) 57.0																																						
Rated Torque (Nm)		1.2	2.2	3.1	3.9	2.2	4.2	5.9	7.5	9.0	3.3	6.2	9.2	11.9	14.7	6.3	10.5	14.2	17.0	21.4	21.4	21.4	21.4	21.4	21.4	21.4	21.4	21.4	21.4	21.4	21.4	21.4	21.4	21.4	21.4	21.4	21.4	21.4	21.4	
Stall Current (A)		1.4	2.6	3.7	4.8	2.7	5.0	7.0	9.0	10.8	4.3	7.9	11.3	15.0	19.0	7.9	13.5	19.1	23.0	28.0	28.0	28.0	28.0	28.0	28.0	28.0	28.0	28.0	28.0	28.0	28.0	28.0	28.0	28.0	28.0	28.0	28.0	28.0	28.0	
Rated Power (kW)		0.38	0.69	0.97	1.23	0.69	1.32	1.85	2.36	2.83	1.04	1.95	2.89	3.74	4.62	1.98	3.30	4.46	5.22	6.06	6.06	6.06	6.06	6.06	6.06	6.06	6.06	6.06	6.06	6.06	6.06	6.06	6.06	6.06	6.06	6.06	6.06	6.06	6.06	6.06
R (ph-ph) (Ohms)		18.9	6.26	3.50	2.38	8.03	2.68	1.57	1.03	0.77	4.01	1.30	0.73	0.47	0.37	1.90	0.59	0.31	0.20	0.15	0.15	0.15	0.15	0.15	0.15	0.15	0.15	0.15	0.15	0.15	0.15	0.15	0.15	0.15	0.15	0.15	0.15	0.15	0.15	0.15
L (ph-ph) (mH)		42.5	18.4	11.9	8.82	25.6	12.0	7.91	5.60	4.65	20.1	9.16	6.07	4.26	3.49	15.0	6.85	4.20	2.73	2.73	2.73	2.73	2.73	2.73	2.73	2.73	2.73	2.73	2.73	2.73	2.73	2.73	2.73	2.73	2.73	2.73	2.73	2.73	2.73	2.73
Rated Speed 4000 (rpm)		Kt (Nm/A) 0.72 Ke (V/krpm) 44.0																																						
Rated Torque (Nm)		1.1	1.9	2.6	3.3	2.0	3.2	4.4	5.5	6.6	2.9	5.4	7.3	8.6	10.2	4.2	8.2	10.2	12.5	15.0	15.0	15.0	15.0	15.0	15.0	15.0	15.0	15.0	15.0	15.0	15.0	15.0	15.0	15.0	15.0	15.0	15.0	15.0	15.0	15.0
Stall Current (A)		1.9	3.4	4.8	6.2	3.5	6.5	9.1	11.6	14.0	5.6	10.2	14.7	19.4	24.9	10.2	17.5	24.9	30.6	36.0	36.0	36.0	36.0	36.0	36.0	36.0	36.0	36.0	36.0	36.0	36.0	36.0	36.0	36.0	36.0	36.0	36.0	36.0	36.0	36.0
Rated Power (kW)		0.46	0.80	1.09	1.38	0.84	1.34	1.84	2.30	2.76	1.21	2.26	3.06	3.60	4.29	1.76	3.43	4.48	5.22	6.06	6.06	6.06	6.06	6.06	6.06	6.06	6.06	6.06	6.06	6.06	6.06	6.06	6.06	6.06	6.06	6.06	6.06	6.06	6.06	6.06
R (ph-ph) (Ohms)		10.2	3.39	1.92	1.48	5.15	1.64	0.92	0.62	0.43	2.62	0.82	0.44	0.29	0.20	1.20	0.36	0.20	0.14	0.10	0.10	0.10	0.10	0.10	0.10	0.10	0.10	0.10	0.10	0.10	0.10	0.10	0.10	0.10	0.10	0.10	0.10	0.10	0.10	0.10
L (ph-ph) (mH)		24.6	10.8	7.14	5.42	15.5	6.77	4.61	3.46	2.54	12.6	5.48	3.57	2.53	2.09	9.45	4.08	2.53	1.76	1.40	1.40	1.40	1.40	1.40	1.40	1.40	1.40	1.40	1.40	1.40	1.40	1.40	1.40	1.40	1.40	1.40	1.40	1.40	1.40	1.40
Rated Speed 6000 (rpm)		Kt (Nm/A) 0.47 Ke (V/krpm) 28.5																																						
Rated Torque (Nm)		1.0	1.8	2.4	3.0	1.7	2.7	3.7	4.8	5.8	2.7	4.7	6.6	8.1	9.7	3.6	6.2	8.1	10.2	12.5	12.5	12.5	12.5	12.5	12.5	12.5	12.5	12.5	12.5	12.5	12.5	12.5	12.5	12.5	12.5	12.5	12.5	12.5	12.5	12.5
Stall Current (A)		2.8	5.2	7.4	9.5	5.4	9.9	14.0	17.9	21.8	8.6	15.7	21.8	28.0	34.3	15.7	24.9	34.3	42.9	52.2	52.2	52.2	52.2	52.2	52.2	52.2	52.2	52.2	52.2	52.2	52.2	52.2	52.2	52.2	52.2	52.2	52.2	52.2	52.2	52.2
Rated Power (kW)		0.63	1.13	1.51	1.88	1.07	1.70	2.32	3.02	3.60	1.70	2.95	4.08	5.06	6.06	2.26	4.48	6.06	7.29	8.64	8.64	8.64	8.64	8.64	8.64	8.64	8.64	8.64	8.64	8.64	8.64	8.64	8.64	8.64	8.64	8.64	8.64	8.64	8.64	8.64
R (ph-ph) (Ohms)		4.49	1.49	0.95	0.65	2.01	0.67	0.35	0.26	0.18	0.96	0.30	0.18	0.12	0.09	0.49	0.14	0.08	0.05	0.04	0.04	0.04	0.04	0.04	0.04	0.04	0.04	0.04	0.04	0.04	0.04	0.04	0.04	0.04	0.04	0.04	0.04	0.04	0.04	0.04
L (ph-ph) (mH)		10.7	4.73	3.10	2.33	6.41	3.01	1.77	1.40	1.02	4.80	2.09	1.40	1.02	0.76	3.96	1.76	1.02	0.76	0.58	0.58	0.58	0.58	0.58	0.58	0.58	0.58	0.58	0.58	0.58	0.58	0.58	0.58	0.58	0.58	0.58	0.58	0.58	0.58	0.58

The information contained in this specification is for guidance only and does not form part of any contract.
CTDynamics Limited have an ongoing process of development and reserve the right to change the specification without notice.

▲ Consult factory

N/A Not available

Specification - UM, EZ, SL, DM (Full UL recognition)

The UL symbol  together with "E215243" file number indicates full motor recognition by Underwriters Laboratory (UL) in USA and by Canadian Standards Authority (CSA) in Canada.

Note: Hybrid motors with terminal power connections and certain special motor variants are not offered with full UL recognition.

Physical

Insulation Class	Class H, BS EN 60034-1.
Insulation System	USR & CNR Class H Electrical Insulation System designated 'CTD/1S/2000/01'.
Degree of Balance	Rotor balanced to ISO 1940 (BS 6861) G 6.3 (half key convention to ISO 8821).
Temperature Monitoring	PTC thermistor, 170°C switch temperature.
Bearing System	Preloaded ball bearings, metal shielded, high temperature grease.
Electrical Connections	Connector or terminal box for power and brake; connector for feedback devices and thermistor.
Flange Mounting	IEC 60072-1 as standard / NEMA MG-7 optional.
Output Shaft	Plain shaft as standard. Output key is optional (to IEC 60072-1).

Environmental

Ingress Protection	Motor, excluding mounting face, and with mating connectors and cables fitted. Ingress protection : IP65S.
Operating Temperature	Specified performance at 0-40°C ambient.
Storage Temperature	-20°C to 70°C.
Insulation Class	H (180°C) Insulation system. The CTD/IS/2000/01 insulation system number on the motor number plate, together with the  symbol, denotes a UL recognised insulation system, file number E214439.
Temperature Rise (Winding)	For motors with resolver feedback 125°C over ambient of 40°C Max. For motors with optical feedback 100°C over ambient of 40°C Max.

Nameplate

Values shown for K_E ; K_T , I_0 , stall/rated torque ($M_{0/N}$) and power (P_N) are for motor at full maximum rating in a 40 degrees C ambient.

$K_{E(NOM)}$ is the motor's back e.m.f. at 20 degrees C.



3ø, 8pole, PM Servomotor

- Indicates number of poles. This motor has 8 poles or 4 pole pairs.
- Electrical frequency = (rpm/60) x (number of pole pairs)

190UMD201CBAXA

- Motor type number – ref. Ordering information, Section 2, page 1.

Note that the X indicates that a gearbox is fitted – for gearbox details see gearbox label and section 7 of this manual.

VPWM 380 /480 Vac

- for use with a VPWM (Voltage Pulse Width Modulation) Drive with supply voltage as indicated.

Brake 24 Vdc; 1.1 A

Brake supply requirements

$K_E (NOM)$ 147V/krpm

K_E ac Volts per 1000rpm with motor at 20°C

$M_{0/N}$ 78.0 /60.0 Nm

M_0 (Stall torque) = 78.0Nm; M_N (rated torque @ nominal speed rpm) = 60.0 Nm

P_N 12.6kW

P_N (Power @ nominal speed) = 12.6 kW

$K_T (HOT)$ 2.24 Nm/A; $I_0 (HOT)$ 34.8 A

K_T (Torque Constant) at maximum operating temperature = 2.24 Nm/A

$I_0 (HOT)$ (Stall Current at maximum operating temperature) = 34.8 A

IP65S

Ingress Protection = IP65S (excludes front shaft seal)

Insulation Class $\text{\textcircled{H}}$

Windings are built to Class H standard (180°C) Motor will have further ambient and Δt restrictions. Refer below.

0-40°C / $\Delta 125^\circ\text{C}$

Ambient temperature range / (delta) winding temperature increase above ambient (at full rating)

T_{CW} 632s

Thermal Time-constant of copper winding with respect to iron laminations.

n_N / MAX 2000 /3265 rpm

n_N (nominal speed) = 2000 rpm / n_{MAX} (maximum speed) = 3265 rpm (at maximum drive supply voltage and no load or low torque)

Note: maximum speed given for motor includes limit of feedback device, but excludes drive limits.

f-b resolver

Feedback Device is a resolver.

Other Devices are as per the following table

Feedback Type	Name
Resolver	"resolver"
Incremental 4096	"4096ppr"
Incremental 1024	"1024ppr"
Incremental 2048	"2048ppr"
CT Coder & SLM3	"SLM3"
Sincos SRM50 1024	"SRM50"
Sincos SRS50 1024	"SRS50"



CE (Conformité Européenne) mark and reference number.

Note: A "Declaration of Incorporation" is contained within the Unimotor Installation Guide that accompanies each motor.

CTD/IS/2000/01

UL and CAN/CSA Recognition marking for the Motor Insulation system USR and CNR Class 180(H) electrical insulation system designated "CTD/IS/2000/01".

The UL list number for this is E214439

Note: USR - United States Standards Recognized.

CNR - Canadian National Standards Recognized in accordance with CAN/CSA C22.2 No. 0-M91, Appendix B.



UL and CAN/CSA recognition marking for the Unimotor types UM; SL; EZ; DM.

This UL File number signifies recognition for the complete motor

Note: Unimotors with Hybrid boxes for motor power connection and "S" special designated motors are not UL recognised and for these motors this mark will be excluded.

Performance Definitions

Specifications differ for the UL motor only by presentation of the performance data in the tables and upon the motor label. Magnetic characteristics vary with motor temperature and the parameters shown are for worst case full rating in a 40 degrees C ambient, whereas for standard motors it has been conventional to quote nominal values for Kt and current. However, it should be noted that stall and rated torque have always been depicted as for worst case for both standard and now UL motor versions.

A total of four different tables are shown in two groups of two. When referring to tables, please be sure to select the table relevant to requirements.

There are two voltage ranges:

3. UM, SL, DM motors for drives requiring 380-480Vac supply
4. EZ motors for drives requiring 200-240Vac supply

Each of these is sub-divided into two temperature ranges:

- c) $\Delta t = 100^{\circ}\text{C}$ for motors with encoders
- d) $\Delta t = 125^{\circ}\text{C}$ for motors with resolvers

Class H - UL and CSA recognised Insulation System

Class H is a classification of the temperature rating of the motor winding insulation system.

Class H rating has a maximum average winding (copper) wire temperature of 180°C .

All UM, DM, EZ and SL motors have identical insulation systems complying with class H temperature rating irrespective of Δt_{max} .

The Insulation System designated "CTD/IS/2000/01" is recognised by the Underwriters Laboratories (UL, USA.) and CSA (Canadian Standards Authority) for voltage and material safety compliance.

Δt temperature

Δt temperature is the temperature difference between the copper wires of the motor winding and the ambient air temperature surrounding the motor.

Δt_{max} temperatures are allocated to CTD motors as follows:

$\Delta t_{\text{max}} = 100^{\circ}\text{C}$, is applicable to all motors fitted with optical encoder feedback due to their maximum operating temperature. $\Delta t_{\text{max}} = 100^{\circ}\text{C}$ is a little lower than a Class F winding rating for 40°C motor ambient air temperature. (Class F has 155°C max average winding temperature)

$\Delta t_{\text{max}} = 125^{\circ}\text{C}$, is applicable to UM and DM motors fitted with resolver feedback.

Rating corresponds to a Class H winding rating of 180°C . For this higher Δt_{max} , a larger winding current is possible, and hence a larger torque rating.

Winding Thermal Time Constant (tc) seconds

The thermal time constant of the winding with respect to the stator temperature as referenced in the exponential temperature rise given by the formulae: -

Winding temperature at time t seconds = $T_0 + T_1(1 - e^{-t/t_c})$

Where T_0 is initial temperature, T_1 is final winding temperature and t_c = thermal time constant (seconds)

Note that temp = 63.2% of T_1 when $t = t_c$

A thermal protection trip is provided by the drive, based upon calculations using elapsed time, current measurement, and the parameter settings set by the user or directly from the motor map data.

UM, EZ and DM motor windings are ultimately protected by thermistor devices located in the winding overhangs. These thermistors must be connected to the appropriate drive inputs via the motor feedback signal connector. (For pin allocations of signal connectors, refer to section 7)

The improved thermal modelling of the SL motor by the M'Ax and MultiAx drive software renders the need for thermistors to be unnecessary.

Stall Torque

This is the maximum continuous torque within the Continuous Zone at zero or low speeds.

Maximum continuous torque ratings may be intermittently exceeded for short periods provided that winding Δt_{max} temperature is not exceeded.

As with rated torque, the ultimate limiting factor is winding temperature rise:

Δt_{max} = maximum winding temperature rise above ambient.
= 100°C or 125°C according to motor type

For stall conditions, the heating occurs in the copper windings due to I^2R losses, plus some ac ripple current loss due to the drive switching frequency.

Peak Torque

Peak torque is the maximum torque that can be safely applied to the motor at any time, provided that the maximum Δt temperature is never exceeded.

Rated Torque

This is the continuously rated torque at full rated speed.

This will be less than stall torque, because as the motor turns, magnetic lines of flux move through the stator laminations creating additional iron losses that increase with speed, also, to a lesser extent, viscous friction losses are added.

Rated Speed

This is the normal maximum speed for the motor.

The motor speed can be controlled to any speed subject to voltage limits and drive constraints as shown by the Intermittent Zone of the graphs. (see "Speed Limit")

A higher speed motor has fewer winding turns, but requires a higher current to produce the same torque as a similar lower speed motor.

The induced motor voltage at rated speed and no load must be sufficiently less than the supply voltage, to allow for additional voltage across the resistance and inductance of windings as torque (approx = current) is applied.

Rated Power

This is the product of rated speed (radians/sec) and torque (Nm) expressed in Watts (W).

Twice the speed gives twice the output power at the same torque level.

Motor Efficiency

Defined as (power out) / (power in) and expressed as a percentage, motor efficiencies are typically > 95% at full power.

At no load and low torque levels, drive waveforms may distort due to poor resolution at low current, causing iron loss, low efficiency and an unexpected motor temperature rise.

Voltage Constant (Ke) Volt (rms)/krpm

This is the phase-phase rms voltage generated at the stator when the shaft is back-driven at 1000rpm with rotor at 20°C.

Torque Constant (Kt) Nm/A(rms)

As for a brushed motor, a brushless commutating motor delivers torque proportional to current, such that torque = $K_t \times$ current. Where $K_t = 0.0165 \times K_e$ (at 20°C).

Magnets used on all motors are affected by temperature, such that K_t and K_e reduce with increasing temperature of magnets. K_t and K_e reduce by 0.1% / °C for all 75 – 142 motors; and by 0.035% / °C for 190 motors. Temperature of magnets may be assumed to reach 87% of winding temperature.

Stall Current A rms

Stall Current = (Stall Torque) / K_t

Motor label and tables quote stall current when motor is at full power in maximum ambient.

Rated Current A rms

Rated Current = (Rated Torque) / K_t

Pole Pairs

75–142 motors have 6 poles = 3 pole pairs

190 motors have 8 poles = 4 pole pairs

UM & SL servo motor (UL recog.) technical specifications For 3 Phase VPWM Drives 380 - 480Vrms

v.1BM, last updated: 17/3/03

Unimotors with Encoder Feedback
 $\Delta t = 100 \text{ degC}, 40 \text{ degC ambient}$

Stall torque, stall current; Kt, Ke, rated torque and power relate to maximum continuous operation in a 40 °C ambient

All data subject to +/-10% tolerance



All Speeds	75				95				115				142				190							
	A	B	C	D	A	B	C	D	E	A	B	C	D	E	A	B	C	D						
Continuous Stall Torque (Nm)	1.2	2.2	3.1	3.9	2.3	4.3	5.9	7.5	9.0	3.5	6.6	9.4	12.4	15.3	6.3	10.8	15.3	19.8	23.4	21.8	41.1	58.7	73.2	
Peak Torque (Nm)	3.6	6.6	9.3	11.7	6.9	12.9	17.7	22.5	27.0	10.5	19.8	28.2	37.2	45.9	18.9	32.4	45.9	59.4	70.2	65.4	123	176	219	
High Inertia (kgcm ²)	1.2	1.6	2.1	2.5	3.5	4.5	5.6	6.7	7.8	9.7	12.0	14.3	16.6	18.8	21.6	28.0	34.3	40.7	47.0	93.5	141	188	235	
Standard Inertia (kgcm ²)	0.6	1.0	1.5	1.9	1.4	2.5	3.6	4.7	5.8	3.2	5.5	7.8	10.0	12.3	7.8	14.1	20.5	26.8	33.1	50.0	97.0	144	191	
Weight (kg)	3.0	3.7	4.4	5.1	5.0	6.1	7.2	8.3	9.5	6.5	8.2	9.9	11.6	13.2	10.9	13.2	15.5	17.8	20.5	26.0	33.0	40.0	48.0	
Winding Thermal Time Const.(sec)	81	74	94	100	172	168	183	221	228	175	185	198	217	241	213	217	275	301	365	240	242	319	632	
Maximum Cogging (Nm)	0.02	0.03	0.04	0.05	0.03	0.06	0.08	0.10	0.13	0.06	0.10	0.14	0.18	0.21	0.09	0.16	0.23	0.30	0.35	0.30	0.54	0.72	0.99	
Rated Speed 2000 (rpm)																	Kt (Nm/A) 2.10				Kt (Nm/A) 2.26			
Ke(NOM) = 147 V/krpm																	Ke (V/krpm) 129				Ke (V/krpm) 138			
Rated Torque (Nm)	1.1	2.1	3.0	3.8	2.2	4.0	5.5	6.9	8.2	3.2	6.1	8.7	10.8	14.0	5.9	10.3	14.6	18.4	21.3	20.0	36.9	50.4		
Continuous Stall Current (A)	0.6	1.0	1.5	1.9	1.1	2.0	2.8	3.6	4.3	1.7	3.1	4.5	5.9	7.3	3.0	5.1	7.3	9.4	11.1	9.6	18.2	26.0		
Rated Power (kW)	0.23	0.44	0.63	0.80	0.46	0.84	1.15	1.45	1.72	0.67	1.28	1.82	2.26	2.93	1.24	2.16	3.06	3.85	4.46	4.19	7.73	10.6		
R (ph-ph) (Ohms)	144	48.2	25.0	15.7	59.0	17.0	9.90	6.00	4.30	27.8	8.55	4.55	2.96	2.17	12.5	3.60	2.10	1.35	0.98	1.80	0.56	0.33		
L (ph-ph) (mH)	214	99.2	59.2	44.7	131	54.5	36.5	25.6	18.9	94.6	40.5	25.7	18.6	14.7	58.0	29.8	18.7	13.6	10.7	28.1	13.0	8.90		
Rated Speed 3000 (rpm)																	Kt (Nm/A) 1.40				Kt (Nm/A) 1.51			
Ke(NOM) = 98 V/krpm																	Ke (V/krpm) 85.8				Ke (V/krpm) 92.3			
Rated Torque (Nm)	1.1	2.0	2.8	3.5	2.0	3.9	5.4	6.8	8.1	3.0	5.5	8.1	10.4	12.6	5.4	9.0	12.2	15.8	18.0	19.2	33.0	35.0		
Continuous Stall Current (A)	0.9	1.6	2.2	2.8	1.6	3.1	4.2	5.4	6.4	2.5	4.7	6.7	8.8	10.9	4.5	7.7	10.9	14.1	16.7	14.5	27.3	39.0		
Rated Power (kW)	0.35	0.63	0.88	1.10	0.63	1.23	1.70	2.14	2.54	0.94	1.73	2.54	3.27	3.96	1.70	2.83	3.83	4.96	5.65	6.03	10.4	11.0		
R (ph-ph) (Ohms)	60.8	20.1	10.5	7.5	24.5	6.80	4.00	2.50	2.00	12.6	3.86	2.02	1.40	1.10	5.63	1.72	0.94	0.61	0.44	0.79	0.30	0.14		
L (ph-ph) (mH)	98.4	41.8	27.6	19.7	57.9	24.3	15.5	10.9	8.50	43.1	18.6	11.4	8.60	7.40	31.0	13.3	8.30	6.10	4.80	13.2	6.11	3.60		
Rated Speed 4000 (rpm)																	Kt (Nm/A) 1.05				Kt (Nm/A) 1.13			
Ke(NOM) = 73.5 V/krpm																	Ke (V/krpm) 64.4				Ke (V/krpm) 69.2			
Rated Torque (Nm)	1.0	1.7	2.3	2.9	1.8	3.0	4.0	4.9	5.7	2.5	4.7	6.3	7.5	8.7	3.6	7.0	8.9	10.7	12.2	12.2	22.2	22.3		
Continuous Stall Current (A)	1.1	2.1	2.9	3.7	2.2	4.1	5.6	7.1	8.6	3.3	6.3	8.9	11.8	14.6	6.0	10.3	14.6	18.8	22.3	19.2	36.0	48.6		
Rated Power (kW)	0.42	0.71	0.96	1.21	0.75	1.26	1.68	2.05	2.39	1.05	1.97	2.64	3.14	3.64	1.51	2.93	3.73	4.48	5.11	5.11	9.48	11.6		
R (ph-ph) (Ohms)	36.8	10.5	6.30	4.20	12.7	4.08	2.10	1.03	0.73	6.91	2.14	1.16	0.73	0.57	3.12	1.00	0.53	0.35	0.24	0.44	0.30	0.14		
L (ph-ph) (mH)	54.9	24.8	14.9	10.8	31.5	13.6	8.50	6.30	4.80	23.5	10.2	6.60	4.70	3.90	17.6	7.50	4.70	3.60	2.70	13.2	6.11	3.60		
Rated Speed 6000 (rpm)																	Kt (Nm/A) 0.70				Kt (Nm/A) 0.70			
Ke(NOM) = 49.0 V/krpm																	Ke (V/krpm) 42.9				Ke (V/krpm) 42.9			
Rated Torque (Nm)	0.9	1.6	2.1	2.6	1.3	2.1	2.8	3.3	3.7	2.2	4.0	5.1	5.1	5.1	2.9	4.5	4.5	4.5	4.5	4.5	8.5	8.5		
Continuous Stall Current (A)	1.7	3.1	4.4	5.6	3.3	6.1	8.4	10.7	12.8	5.0	9.4	13.4	13.4	9.0	15.4	15.4	15.4	15.4	15.4	30.0	30.0			
Rated Power (kW)	0.57	1.01	1.32	1.63	0.82	1.32	1.76	2.07	2.32	1.38	2.51	3.20	3.20	1.82	2.83	2.83	2.83	2.83	2.83	5.66	5.66			
R (ph-ph) (Ohms)	15.0	5.00	2.66	1.90	5.45	1.82	1.05	0.62	0.48	3.1	0.97	0.50	0.50	1.42	0.46	0.46	0.46	0.46	0.46	0.92	0.92			
L (ph-ph) (mH)	24.0	10.6	6.80	4.80	14.1	6.00	3.80	2.70	2.10	15.54	4.81	2.94	2.94	7.72	3.44	3.44	3.44	3.44	3.44	6.88	6.88			

N/A Not available ▲ Consult factory

The information contained in this specification is for guidance only and does not form part of any contract. CTDynamics Limited have an ongoing process of development and reserve the right to change the specification without notice.

UM & DM servo motor (UL recog.) technical specifications For 3 Phase VPWM Drives 380 - 480Vrms

v. 19M, last updated: 11/20/03

Unimotors with Resolver Feedback
 $\Delta t = 125 \text{ degC}$, 40 degC ambient



Stall torque; stall current; Kt; Ke; rated torque and power relate to maximum continuous operation in a 40 °C ambient

All data subject to +/-10% tolerance

All Speeds	75			95			115			142			190																																																																																																															
	A	B	C	D	E	A	B	C	D	E	A	B	C	D	E	A	B	C	D																																																																																																									
Continuous Stall Torque (Nm)	1.3	2.4	3.4	4.4	2.5	4.6	6.5	8.3	10.0	4.0	7.3	10.5	13.9	17.6	7.3	12.5	17.7	22.9	27.0																																																																																																									
Peak Torque (Nm)	3.6	6.6	9.3	11.7	6.9	12.9	17.7	22.5	27.0	10.5	19.8	28.2	37.2	45.9	18.9	32.4	45.9	59.4	70.2																																																																																																									
High Inertia (kgcm ²)	1.2	1.6	2.1	2.5	3.5	4.5	5.6	6.7	7.8	9.7	12.0	14.3	16.6	18.8	21.6	28.0	34.3	40.7	47.0																																																																																																									
Standard Inertia (kgcm ²)	0.6	1.0	1.5	1.9	1.4	2.5	3.6	4.7	5.8	3.2	5.5	7.8	10.0	12.3	7.8	14.1	20.5	26.8	33.1																																																																																																									
Weight (kg)	3.0	3.7	4.4	5.1	5.0	6.1	7.2	8.3	9.5	6.5	8.2	9.9	11.6	13.2	10.9	13.2	15.5	17.8	20.5																																																																																																									
Winding Thermal Time Const. (sec)	81	74	94	100	172	168	183	221	228	175	185	198	217	241	213	217	275	301	365																																																																																																									
Maximum Cogging (Nm)	0.02	0.03	0.04	0.05	0.03	0.06	0.08	0.10	0.13	0.06	0.10	0.14	0.18	0.21	0.09	0.16	0.23	0.30	0.35																																																																																																									
Rated Speed 2000 (rpm) Ke(NOM) = 147 V/krpm	<table border="1"> <thead> <tr> <th colspan="3">Kt (Nm/A) 2.06</th> <th colspan="3">Ke (V/krpm) 126</th> </tr> </thead> <tbody> <tr> <td>Rated Torque (Nm)</td><td>1.2</td><td>2.3</td><td>3.3</td><td>4.2</td><td>2.3</td><td>4.3</td><td>6.0</td><td>7.6</td><td>9.1</td><td>3.7</td><td>6.8</td><td>9.8</td><td>12.3</td><td>16.6</td><td>6.8</td><td>12.0</td><td>17.0</td><td>21.4</td><td>24.9</td> </tr> <tr> <td>Continuous Stall Current (A)</td><td>0.6</td><td>1.2</td><td>1.7</td><td>2.1</td><td>1.2</td><td>2.2</td><td>3.2</td><td>4.0</td><td>4.9</td><td>1.9</td><td>3.6</td><td>5.1</td><td>6.8</td><td>8.6</td><td>3.6</td><td>6.1</td><td>8.6</td><td>11.1</td><td>13.1</td> </tr> <tr> <td>Rated Power (kW)</td><td>0.25</td><td>0.48</td><td>0.69</td><td>0.88</td><td>0.48</td><td>0.90</td><td>1.26</td><td>1.59</td><td>1.91</td><td>0.77</td><td>1.42</td><td>2.05</td><td>2.58</td><td>3.48</td><td>1.42</td><td>2.51</td><td>3.56</td><td>4.48</td><td>5.22</td> </tr> <tr> <td>R (ph-ph) (Ohms)</td><td>144</td><td>48.2</td><td>25.0</td><td>15.7</td><td>59.0</td><td>17.0</td><td>9.0</td><td>6.00</td><td>4.30</td><td>27.8</td><td>8.55</td><td>4.55</td><td>2.96</td><td>2.17</td><td>12.5</td><td>3.60</td><td>2.10</td><td>1.35</td><td>0.98</td> </tr> <tr> <td>L (ph-ph) (mH)</td><td>214</td><td>99.2</td><td>59.2</td><td>44.7</td><td>131</td><td>54.5</td><td>36.5</td><td>25.6</td><td>18.9</td><td>94.6</td><td>40.5</td><td>25.7</td><td>18.6</td><td>14.7</td><td>58.0</td><td>29.8</td><td>18.7</td><td>13.6</td><td>10.7</td> </tr> </tbody> </table>																		Kt (Nm/A) 2.06			Ke (V/krpm) 126			Rated Torque (Nm)	1.2	2.3	3.3	4.2	2.3	4.3	6.0	7.6	9.1	3.7	6.8	9.8	12.3	16.6	6.8	12.0	17.0	21.4	24.9	Continuous Stall Current (A)	0.6	1.2	1.7	2.1	1.2	2.2	3.2	4.0	4.9	1.9	3.6	5.1	6.8	8.6	3.6	6.1	8.6	11.1	13.1	Rated Power (kW)	0.25	0.48	0.69	0.88	0.48	0.90	1.26	1.59	1.91	0.77	1.42	2.05	2.58	3.48	1.42	2.51	3.56	4.48	5.22	R (ph-ph) (Ohms)	144	48.2	25.0	15.7	59.0	17.0	9.0	6.00	4.30	27.8	8.55	4.55	2.96	2.17	12.5	3.60	2.10	1.35	0.98	L (ph-ph) (mH)	214	99.2	59.2	44.7	131	54.5	36.5	25.6	18.9	94.6	40.5	25.7	18.6	14.7	58.0	29.8	18.7	13.6	10.7
Kt (Nm/A) 2.06			Ke (V/krpm) 126																																																																																																																									
Rated Torque (Nm)	1.2	2.3	3.3	4.2	2.3	4.3	6.0	7.6	9.1	3.7	6.8	9.8	12.3	16.6	6.8	12.0	17.0	21.4	24.9																																																																																																									
Continuous Stall Current (A)	0.6	1.2	1.7	2.1	1.2	2.2	3.2	4.0	4.9	1.9	3.6	5.1	6.8	8.6	3.6	6.1	8.6	11.1	13.1																																																																																																									
Rated Power (kW)	0.25	0.48	0.69	0.88	0.48	0.90	1.26	1.59	1.91	0.77	1.42	2.05	2.58	3.48	1.42	2.51	3.56	4.48	5.22																																																																																																									
R (ph-ph) (Ohms)	144	48.2	25.0	15.7	59.0	17.0	9.0	6.00	4.30	27.8	8.55	4.55	2.96	2.17	12.5	3.60	2.10	1.35	0.98																																																																																																									
L (ph-ph) (mH)	214	99.2	59.2	44.7	131	54.5	36.5	25.6	18.9	94.6	40.5	25.7	18.6	14.7	58.0	29.8	18.7	13.6	10.7																																																																																																									
Rated Speed 3000 (rpm) Ke(NOM) = 98 V/krpm	<table border="1"> <thead> <tr> <th colspan="3">Kt (Nm/A) 1.37</th> <th colspan="3">Ke (V/krpm) 84.0</th> </tr> </thead> <tbody> <tr> <td>Rated Torque (Nm)</td><td>1.2</td><td>2.2</td><td>3.1</td><td>3.9</td><td>2.2</td><td>4.2</td><td>5.9</td><td>7.5</td><td>9.0</td><td>3.3</td><td>6.2</td><td>9.2</td><td>11.9</td><td>14.7</td><td>6.3</td><td>10.5</td><td>14.2</td><td>18.4</td><td>21.0</td> </tr> <tr> <td>Continuous Stall Current (A)</td><td>0.9</td><td>1.8</td><td>2.5</td><td>3.2</td><td>1.8</td><td>3.4</td><td>4.7</td><td>6.1</td><td>7.3</td><td>2.9</td><td>5.3</td><td>7.7</td><td>10.1</td><td>12.8</td><td>5.3</td><td>9.1</td><td>12.9</td><td>16.7</td><td>19.7</td> </tr> <tr> <td>Rated Power (kW)</td><td>0.38</td><td>0.69</td><td>0.97</td><td>1.23</td><td>0.69</td><td>1.32</td><td>1.85</td><td>2.36</td><td>2.83</td><td>1.04</td><td>1.95</td><td>2.89</td><td>3.74</td><td>4.62</td><td>1.98</td><td>3.30</td><td>4.46</td><td>5.78</td><td>6.60</td> </tr> <tr> <td>R (ph-ph) (Ohms)</td><td>60.8</td><td>20.1</td><td>10.5</td><td>7.5</td><td>24.5</td><td>6.80</td><td>4.00</td><td>2.50</td><td>2.00</td><td>12.6</td><td>3.86</td><td>2.02</td><td>1.40</td><td>1.10</td><td>5.63</td><td>1.72</td><td>0.94</td><td>0.61</td><td>0.44</td> </tr> <tr> <td>L (ph-ph) (mH)</td><td>98.4</td><td>41.8</td><td>27.6</td><td>19.7</td><td>57.9</td><td>24.3</td><td>15.5</td><td>10.9</td><td>8.50</td><td>43.1</td><td>18.6</td><td>11.4</td><td>8.60</td><td>7.40</td><td>31.0</td><td>13.3</td><td>8.30</td><td>6.10</td><td>4.80</td> </tr> </tbody> </table>																		Kt (Nm/A) 1.37			Ke (V/krpm) 84.0			Rated Torque (Nm)	1.2	2.2	3.1	3.9	2.2	4.2	5.9	7.5	9.0	3.3	6.2	9.2	11.9	14.7	6.3	10.5	14.2	18.4	21.0	Continuous Stall Current (A)	0.9	1.8	2.5	3.2	1.8	3.4	4.7	6.1	7.3	2.9	5.3	7.7	10.1	12.8	5.3	9.1	12.9	16.7	19.7	Rated Power (kW)	0.38	0.69	0.97	1.23	0.69	1.32	1.85	2.36	2.83	1.04	1.95	2.89	3.74	4.62	1.98	3.30	4.46	5.78	6.60	R (ph-ph) (Ohms)	60.8	20.1	10.5	7.5	24.5	6.80	4.00	2.50	2.00	12.6	3.86	2.02	1.40	1.10	5.63	1.72	0.94	0.61	0.44	L (ph-ph) (mH)	98.4	41.8	27.6	19.7	57.9	24.3	15.5	10.9	8.50	43.1	18.6	11.4	8.60	7.40	31.0	13.3	8.30	6.10	4.80
Kt (Nm/A) 1.37			Ke (V/krpm) 84.0																																																																																																																									
Rated Torque (Nm)	1.2	2.2	3.1	3.9	2.2	4.2	5.9	7.5	9.0	3.3	6.2	9.2	11.9	14.7	6.3	10.5	14.2	18.4	21.0																																																																																																									
Continuous Stall Current (A)	0.9	1.8	2.5	3.2	1.8	3.4	4.7	6.1	7.3	2.9	5.3	7.7	10.1	12.8	5.3	9.1	12.9	16.7	19.7																																																																																																									
Rated Power (kW)	0.38	0.69	0.97	1.23	0.69	1.32	1.85	2.36	2.83	1.04	1.95	2.89	3.74	4.62	1.98	3.30	4.46	5.78	6.60																																																																																																									
R (ph-ph) (Ohms)	60.8	20.1	10.5	7.5	24.5	6.80	4.00	2.50	2.00	12.6	3.86	2.02	1.40	1.10	5.63	1.72	0.94	0.61	0.44																																																																																																									
L (ph-ph) (mH)	98.4	41.8	27.6	19.7	57.9	24.3	15.5	10.9	8.50	43.1	18.6	11.4	8.60	7.40	31.0	13.3	8.30	6.10	4.80																																																																																																									
Rated Speed 4000 (rpm) Ke(NOM) = 73.5 V/krpm	<table border="1"> <thead> <tr> <th colspan="3">Kt (Nm/A) 1.03</th> <th colspan="3">Ke (V/krpm) 63.0</th> </tr> </thead> <tbody> <tr> <td>Rated Torque (Nm)</td><td>1.1</td><td>1.9</td><td>2.6</td><td>3.3</td><td>2.0</td><td>3.2</td><td>4.4</td><td>5.5</td><td>6.6</td><td>2.9</td><td>5.4</td><td>7.3</td><td>8.6</td><td>10.0</td><td>4.2</td><td>8.2</td><td>10.4</td><td>12.5</td><td>14.2</td> </tr> <tr> <td>Continuous Stall Current (A)</td><td>1.3</td><td>2.3</td><td>3.3</td><td>4.3</td><td>2.4</td><td>4.5</td><td>6.3</td><td>8.1</td><td>9.7</td><td>3.9</td><td>7.1</td><td>10.2</td><td>13.5</td><td>17.1</td><td>7.1</td><td>12.2</td><td>17.2</td><td>22.3</td><td>25.3</td> </tr> <tr> <td>Rated Power (kW)</td><td>0.46</td><td>0.80</td><td>1.09</td><td>1.38</td><td>0.84</td><td>1.34</td><td>1.84</td><td>2.30</td><td>2.76</td><td>1.21</td><td>2.26</td><td>3.06</td><td>3.60</td><td>4.19</td><td>1.76</td><td>3.43</td><td>4.36</td><td>5.24</td><td>6.00</td> </tr> <tr> <td>R (ph-ph) (Ohms)</td><td>36.8</td><td>10.5</td><td>6.30</td><td>4.20</td><td>12.7</td><td>4.08</td><td>2.10</td><td>1.50</td><td>1.03</td><td>6.91</td><td>2.14</td><td>1.16</td><td>0.73</td><td>0.57</td><td>3.12</td><td>1.00</td><td>0.53</td><td>0.35</td><td>0.25</td> </tr> <tr> <td>L (ph-ph) (mH)</td><td>54.9</td><td>24.8</td><td>14.9</td><td>10.8</td><td>31.5</td><td>13.6</td><td>8.50</td><td>6.30</td><td>4.80</td><td>23.5</td><td>10.2</td><td>6.60</td><td>4.70</td><td>3.90</td><td>17.6</td><td>7.50</td><td>4.70</td><td>3.60</td><td>2.46</td> </tr> </tbody> </table>																		Kt (Nm/A) 1.03			Ke (V/krpm) 63.0			Rated Torque (Nm)	1.1	1.9	2.6	3.3	2.0	3.2	4.4	5.5	6.6	2.9	5.4	7.3	8.6	10.0	4.2	8.2	10.4	12.5	14.2	Continuous Stall Current (A)	1.3	2.3	3.3	4.3	2.4	4.5	6.3	8.1	9.7	3.9	7.1	10.2	13.5	17.1	7.1	12.2	17.2	22.3	25.3	Rated Power (kW)	0.46	0.80	1.09	1.38	0.84	1.34	1.84	2.30	2.76	1.21	2.26	3.06	3.60	4.19	1.76	3.43	4.36	5.24	6.00	R (ph-ph) (Ohms)	36.8	10.5	6.30	4.20	12.7	4.08	2.10	1.50	1.03	6.91	2.14	1.16	0.73	0.57	3.12	1.00	0.53	0.35	0.25	L (ph-ph) (mH)	54.9	24.8	14.9	10.8	31.5	13.6	8.50	6.30	4.80	23.5	10.2	6.60	4.70	3.90	17.6	7.50	4.70	3.60	2.46
Kt (Nm/A) 1.03			Ke (V/krpm) 63.0																																																																																																																									
Rated Torque (Nm)	1.1	1.9	2.6	3.3	2.0	3.2	4.4	5.5	6.6	2.9	5.4	7.3	8.6	10.0	4.2	8.2	10.4	12.5	14.2																																																																																																									
Continuous Stall Current (A)	1.3	2.3	3.3	4.3	2.4	4.5	6.3	8.1	9.7	3.9	7.1	10.2	13.5	17.1	7.1	12.2	17.2	22.3	25.3																																																																																																									
Rated Power (kW)	0.46	0.80	1.09	1.38	0.84	1.34	1.84	2.30	2.76	1.21	2.26	3.06	3.60	4.19	1.76	3.43	4.36	5.24	6.00																																																																																																									
R (ph-ph) (Ohms)	36.8	10.5	6.30	4.20	12.7	4.08	2.10	1.50	1.03	6.91	2.14	1.16	0.73	0.57	3.12	1.00	0.53	0.35	0.25																																																																																																									
L (ph-ph) (mH)	54.9	24.8	14.9	10.8	31.5	13.6	8.50	6.30	4.80	23.5	10.2	6.60	4.70	3.90	17.6	7.50	4.70	3.60	2.46																																																																																																									
Rated Speed 6000 (rpm) Ke(NOM) = 49.0 V/krpm	<table border="1"> <thead> <tr> <th colspan="3">Kt (Nm/A) 0.69</th> <th colspan="3">Ke (V/krpm) 42.0</th> </tr> </thead> <tbody> <tr> <td>Rated Torque (Nm)</td><td>1.0</td><td>1.8</td><td>2.4</td><td>3.0</td><td>1.7</td><td>2.7</td><td>3.7</td><td>4.8</td><td>5.9</td><td>2.7</td><td>4.7</td><td>6.1</td><td>7.3</td><td>8.6</td><td>3.6</td><td>5.7</td><td>7.3</td><td>8.9</td><td>10.4</td> </tr> <tr> <td>Continuous Stall Current (A)</td><td>1.9</td><td>3.5</td><td>5.0</td><td>6.4</td><td>3.6</td><td>6.7</td><td>9.5</td><td>12.1</td><td>14.6</td><td>5.8</td><td>10.7</td><td>15.3</td><td>19.9</td><td>25.3</td><td>10.7</td><td>18.2</td><td>24.3</td><td>31.1</td><td>37.9</td> </tr> <tr> <td>Rated Power (kW)</td><td>0.63</td><td>1.13</td><td>1.51</td><td>1.88</td><td>1.07</td><td>1.70</td><td>2.32</td><td>3.02</td><td>3.71</td><td>1.70</td><td>2.95</td><td>3.83</td><td>4.74</td><td>5.67</td><td>2.26</td><td>3.58</td><td>4.56</td><td>5.54</td><td>6.42</td> </tr> <tr> <td>R (ph-ph) (Ohms)</td><td>15.0</td><td>5.00</td><td>2.66</td><td>1.90</td><td>5.45</td><td>1.82</td><td>1.05</td><td>0.62</td><td>0.48</td><td>3.10</td><td>0.97</td><td>0.50</td><td>0.33</td><td>0.25</td><td>1.42</td><td>0.46</td><td>0.27</td><td>0.18</td><td>0.14</td> </tr> <tr> <td>L (ph-ph) (mH)</td><td>24.0</td><td>10.6</td><td>6.80</td><td>4.80</td><td>14.1</td><td>6.00</td><td>3.80</td><td>2.70</td><td>2.10</td><td>15.5</td><td>4.81</td><td>2.94</td><td>2.00</td><td>1.50</td><td>7.72</td><td>2.34</td><td>1.44</td><td>1.00</td><td>0.70</td> </tr> </tbody> </table>																		Kt (Nm/A) 0.69			Ke (V/krpm) 42.0			Rated Torque (Nm)	1.0	1.8	2.4	3.0	1.7	2.7	3.7	4.8	5.9	2.7	4.7	6.1	7.3	8.6	3.6	5.7	7.3	8.9	10.4	Continuous Stall Current (A)	1.9	3.5	5.0	6.4	3.6	6.7	9.5	12.1	14.6	5.8	10.7	15.3	19.9	25.3	10.7	18.2	24.3	31.1	37.9	Rated Power (kW)	0.63	1.13	1.51	1.88	1.07	1.70	2.32	3.02	3.71	1.70	2.95	3.83	4.74	5.67	2.26	3.58	4.56	5.54	6.42	R (ph-ph) (Ohms)	15.0	5.00	2.66	1.90	5.45	1.82	1.05	0.62	0.48	3.10	0.97	0.50	0.33	0.25	1.42	0.46	0.27	0.18	0.14	L (ph-ph) (mH)	24.0	10.6	6.80	4.80	14.1	6.00	3.80	2.70	2.10	15.5	4.81	2.94	2.00	1.50	7.72	2.34	1.44	1.00	0.70
Kt (Nm/A) 0.69			Ke (V/krpm) 42.0																																																																																																																									
Rated Torque (Nm)	1.0	1.8	2.4	3.0	1.7	2.7	3.7	4.8	5.9	2.7	4.7	6.1	7.3	8.6	3.6	5.7	7.3	8.9	10.4																																																																																																									
Continuous Stall Current (A)	1.9	3.5	5.0	6.4	3.6	6.7	9.5	12.1	14.6	5.8	10.7	15.3	19.9	25.3	10.7	18.2	24.3	31.1	37.9																																																																																																									
Rated Power (kW)	0.63	1.13	1.51	1.88	1.07	1.70	2.32	3.02	3.71	1.70	2.95	3.83	4.74	5.67	2.26	3.58	4.56	5.54	6.42																																																																																																									
R (ph-ph) (Ohms)	15.0	5.00	2.66	1.90	5.45	1.82	1.05	0.62	0.48	3.10	0.97	0.50	0.33	0.25	1.42	0.46	0.27	0.18	0.14																																																																																																									
L (ph-ph) (mH)	24.0	10.6	6.80	4.80	14.1	6.00	3.80	2.70	2.10	15.5	4.81	2.94	2.00	1.50	7.72	2.34	1.44	1.00	0.70																																																																																																									

The information contained in this specification is for guidance only and does not form part of any contract.
 CTD Dynamics Limited have an ongoing process of development and reserve the right to change the specification without notice.

▲ Consult factory

N/A Not available

EZ servo motor (UL recog.) technical specifications For 3 Phase VPWM Drives 200 - 240Vrms

Unimotors with Encoder Feedback $\Delta t = 100 \text{ degC}$, 40 degC ambient

Stall torque; stall current; Kt; Ke; rated torque and power relate to maximum continuous operation in a 40 °C ambient

All data subject to +/-10% tolerance

All Speeds	75					95					115					142					190									
	A	B	C	D	E	A	B	C	D	E	A	B	C	D	E	A	B	C	D	E	A	B	C	D	E					
Continuous Stall Torque (Nm)	1.2	2.2	3.1	3.9	4.3	5.9	6.6	9.4	12.4	15.3	19.8	21.6	28.2	37.2	45.9	59.4	63.3	80.8	108	132	153	166	188	216	234	218	241	260	280	301
Peak Torque (Nm)	3.6	6.6	9.3	11.7	12.9	17.7	19.8	28.2	37.2	45.9	59.4	63.3	80.8	108	132	153	166	188	216	234	218	241	260	280	301	218	241	260	280	301
High Inertia (kgcm ²)	1.2	1.6	2.1	2.5	3.5	4.5	5.6	6.7	7.8	9.7	12.0	14.3	16.6	18.8	21.6	25.0	28.0	34.3	40.7	47.0	50.0	55.0	63.1	73.2	83.2	65.4	70.2	79.5	91.0	103.0
Standard Inertia (kgcm ²)	0.6	1.0	1.5	1.9	1.4	2.5	3.6	4.7	5.8	7.2	8.2	9.9	11.6	13.2	15.5	17.8	20.5	26.8	33.1	39.4	40.0	44.0	50.0	58.0	67.0	50.0	55.0	63.1	73.2	83.2
Weight (kg)	3.0	3.7	4.4	5.1	5.0	6.1	7.2	8.3	9.5	11.6	13.2	15.5	17.8	20.5	23.4	26.8	30.1	36.5	44.0	50.0	50.0	55.0	63.1	73.2	83.2	65.4	70.2	79.5	91.0	103.0
Winding Thermal Time Const.(sec)	81	74	94	100	172	168	183	221	228	275	282	301	365	440	500	500	550	631	732	832	832	910	1030	1190	1320	1190	1320	1530	1780	2030
Maximum Cogging (Nm)	0.02	0.03	0.04	0.05	0.03	0.06	0.08	0.10	0.13	0.16	0.21	0.28	0.36	0.44	0.50	0.50	0.55	0.63	0.73	0.83	0.83	0.91	1.03	1.19	1.32	1.19	1.32	1.53	1.78	2.03
Rated Speed 2000 (rpm) Ke(Nm/A) = 85.5 V/krpm	1.1	2.1	3.0	3.8	2.2	4.0	5.5	6.9	8.2	3.2	6.1	8.7	10.8	14.0	17.5	21.3	23.4	28.2	37.2	45.9	59.4	63.3	80.8	108	132	153	166	188	216	234
Rated Torque (Nm)	1.0	1.8	2.5	3.2	1.9	3.5	4.8	6.1	7.4	2.9	5.4	7.7	10.1	12.5	15.5	19.1	21.3	26.8	33.1	40.0	40.0	44.0	50.0	58.0	67.0	50.0	55.0	63.1	73.2	83.2
Continuous Stall Current (A)	0.23	0.44	0.63	0.80	0.46	0.84	1.15	1.45	1.72	0.67	1.28	1.82	2.26	2.93	3.66	4.46	4.96	5.94	7.32	8.96	11.16	12.48	15.16	18.16	21.56	21.8	24.1	28.0	33.1	38.6
Rated Power (kW)	45.8	15.3	8.52	5.72	19.4	6.2	3.16	2.31	1.71	9.09	2.83	1.51	0.99	0.82	4.28	1.33	0.76	0.45	0.32	0.50	0.15	0.10	0.10	0.10	0.10	0.10	0.10	0.10	0.10	0.10
R (ph-ph) (Ohms)	98.8	43.4	27.9	20.2	59.2	25.8	16.0	12.6	10.1	47.3	20.6	13.1	9.54	7.86	33.7	15.1	10.3	6.96	5.58	3.32	2.73	2.73	2.73	2.73	2.73	2.73	2.73	2.73	2.73	2.73
L (ph-ph) (mH)	1.1	2.0	2.8	3.5	2.0	3.9	5.4	6.8	8.1	3.0	5.5	8.1	10.4	12.6	15.5	19.1	21.3	26.8	33.1	40.0	40.0	44.0	50.0	58.0	67.0	50.0	55.0	63.1	73.2	83.2
Rated Speed 3000 (rpm) Ke(Nm/A) = 57 V/krpm	1.1	2.0	2.8	3.5	2.0	3.9	5.4	6.8	8.1	3.0	5.5	8.1	10.4	12.6	15.5	19.1	21.3	26.8	33.1	40.0	40.0	44.0	50.0	58.0	67.0	50.0	55.0	63.1	73.2	83.2
Rated Torque (Nm)	1.5	2.7	3.8	4.8	2.8	5.3	7.2	9.2	11.0	4.3	8.1	11.5	15.2	18.8	24.3	29.8	33.1	40.0	49.6	60.0	73.2	83.2	103.0	119.0	132.0	119.0	132.0	153.0	178.0	203.0
Continuous Stall Current (A)	0.35	0.63	0.88	1.10	0.63	1.23	1.70	2.14	2.54	0.94	1.73	2.54	3.27	3.96	4.96	5.94	6.44	7.82	9.66	11.76	14.4	16.16	19.6	23.6	28.0	28.0	31.1	36.5	43.6	50.0
Rated Power (kW)	18.9	6.26	3.50	2.38	8.03	2.68	1.57	1.03	0.77	4.01	1.30	0.73	0.47	0.37	1.90	0.59	0.31	0.20	0.14	0.20	0.20	0.20	0.20	0.20	0.20	0.20	0.20	0.20	0.20	0.20
R (ph-ph) (Ohms)	42.5	18.4	11.9	8.82	25.6	12.0	7.91	5.60	4.65	20.1	9.16	6.07	4.26	3.49	15.0	6.85	4.20	2.94	2.36	1.87	1.87	1.87	1.87	1.87	1.87	1.87	1.87	1.87	1.87	1.87
L (ph-ph) (mH)	1.0	1.7	2.3	2.9	1.8	3.0	4.0	4.9	5.7	2.5	4.7	6.3	7.5	9.0	11.1	13.2	15.5	19.1	23.4	28.2	33.1	39.4	47.0	55.0	63.1	63.1	70.2	80.8	93.0	106.0
Rated Speed 4000 (rpm) Ke(Nm/A) = 44.0 V/krpm	1.0	1.7	2.3	2.9	1.8	3.0	4.0	4.9	5.7	2.5	4.7	6.3	7.5	9.0	11.1	13.2	15.5	19.1	23.4	28.2	33.1	39.4	47.0	55.0	63.1	63.1	70.2	80.8	93.0	106.0
Rated Torque (Nm)	1.9	3.5	4.9	6.2	3.7	6.8	9.4	11.9	14.3	5.6	10.5	14.9	19.7	24.3	30.0	36.5	43.6	53.0	64.0	77.0	93.0	108	132	155	181	181	203	236	280	325
Continuous Stall Current (A)	0.42	0.71	0.96	1.21	0.75	1.26	1.68	2.05	2.39	1.05	1.97	2.64	3.14	3.83	4.70	5.66	6.63	8.08	9.86	11.96	14.4	16.6	20.0	23.6	28.0	28.0	31.1	36.5	43.6	50.0
Rated Power (kW)	10.2	3.39	1.92	1.48	5.15	1.64	0.92	0.62	0.43	2.62	0.82	0.44	0.29	0.20	1.00	0.36	0.20	0.14	0.10	0.08	0.08	0.08	0.08	0.08	0.08	0.08	0.08	0.08	0.08	0.08
R (ph-ph) (Ohms)	24.6	10.8	7.14	5.42	15.50	6.77	4.61	3.46	2.54	12.6	5.48	3.57	2.53	2.03	9.45	4.08	2.53	1.78	1.44	1.11	0.88	0.73	0.63	0.55	0.48	0.48	0.48	0.48	0.48	0.48
L (ph-ph) (mH)	1.0	1.7	2.3	2.9	1.8	3.0	4.0	4.9	5.7	2.5	4.7	6.3	7.5	9.0	11.1	13.2	15.5	19.1	23.4	28.2	33.1	39.4	47.0	55.0	63.1	63.1	70.2	80.8	93.0	106.0
Rated Speed 6000 (rpm) Ke(Nm/A) = 28.5 V/krpm	0.9	1.6	2.1	2.6	1.3	2.1	2.8	3.3	3.8	2.2	4.0	5.4	6.6	8.1	9.9	12.0	14.3	17.8	21.6	26.8	33.1	39.4	47.0	55.0	63.1	63.1	70.2	80.8	93.0	106.0
Rated Torque (Nm)	2.9	5.4	7.6	9.6	5.6	10.6	14.5	18.4	22.3	8.6	16.2	22.3	28.2	35.0	42.9	51.8	61.7	75.0	90.0	108.0	129.0	151.0	181.0	216.0	260.0	260.0	295.0	350.0	420.0	500.0
Continuous Stall Current (A)	0.57	1.01	1.32	1.63	0.82	1.32	1.76	2.07	2.40	1.38	2.51	3.32	4.13	5.04	6.16	7.50	8.96	10.96	13.20	15.84	19.20	23.04	28.00	33.60	40.80	40.80	46.80	55.20	66.00	79.20
Rated Power (kW)	4.49	1.49	0.95	0.65	2.01	0.67	0.35	0.26	0.18	0.96	0.30	0.16	0.10	0.07	0.36	0.12	0.07	0.05	0.04	0.03	0.03	0.03	0.03	0.03	0.03	0.03	0.03	0.03	0.03	0.03
R (ph-ph) (Ohms)	10.7	4.73	3.10	2.33	6.41	3.01	1.77	1.40	1.00	4.80	2.09	1.32	0.93	0.73	3.96	1.78	1.11	0.78	0.60	0.45	0.33	0.26	0.22	0.19	0.16	0.16	0.16	0.16	0.16	0.16
L (ph-ph) (mH)	1.0	1.7	2.3	2.9	1.8	3.0	4.0	4.9	5.7	2.5	4.7	6.3	7.5	9.0	11.1	13.2	15.5	19.1	23.4	28.2	33.1	39.4	47.0	55.0	63.1	63.1	70.2	80.8	93.0	106.0

N/A Not available ▲ Consult factory
 The information contained in this specification is for guidance only and does not form part of any contract.
 CTDynamics Limited have an ongoing process of development and reserve the right to change the specification without notice.

EZ servo motor (UL recog.) technical specifications		For 3 Phase VPWM Drives 200 - 240Vrms																																							
		75					95					115					142					190																			
Unimotors with Resolver Feedback Δt = 125 degC, 40 degC ambient		All data subject to ±1-10% tolerance																																							
Stall torque; stall current; Kt; Ke; rated torque and power relate to maximum continuous operation in a 40 °C ambient		v.19M, last updated: 11/20/03																																							
Motor Frame Size (mm)		A				B				C				D				E				A				B				C				D				E			
Frame Length		A				B				C				D				E				A				B				C				D				E			
Continuous Stall Torque (Nm)	1.3	2.4	3.4	4.4	2.5	4.6	6.5	8.3	10.0	4.0	7.3	10.5	13.9	17.6	7.3	12.5	17.7	22.9	27.0	23.2	43.2	62.8	78.0	23.2	43.2	62.8	78.0	23.2	43.2	62.8	78.0										
Peak Torque (Nm)	3.6	6.6	9.3	11.7	6.9	12.9	17.7	22.5	27.0	10.5	19.8	28.2	37.2	45.9	18.9	32.4	45.9	59.4	70.2	65.4	123	176	219	65.4	123	176	219	65.4	123	176	219										
High Inertia (kgcm ²)	1.2	1.6	2.1	2.5	3.5	4.5	5.6	6.7	7.8	9.7	12.0	14.3	16.6	18.8	21.6	28.0	34.3	40.7	47.0	93.5	141	188	235	93.5	141	188	235	93.5	141	188	235										
Standard Inertia (kgcm ²)	0.6	1.0	1.5	1.9	1.4	2.5	3.6	4.7	5.8	3.2	5.5	7.8	10.0	12.3	7.8	14.1	20.5	26.8	33.1	50.0	97.0	144	191	50.0	97.0	144	191	50.0	97.0	144	191										
Weight (kg)	3.0	3.7	4.4	5.1	5.0	6.1	7.2	8.3	9.5	6.5	8.2	9.9	11.6	13.2	10.9	13.2	15.5	17.8	20.5	26.0	33.0	40.0	48.0	26.0	33.0	40.0	48.0	26.0	33.0	40.0	48.0										
Winding Thermal Time Const.(sec)	81	74	94	100	172	168	183	221	228	175	185	198	217	241	213	217	275	301	365	240	242	319	632	240	242	319	632	240	242	319	632										
Maximum Cogging (Nm)	0.02	0.03	0.04	0.05	0.03	0.06	0.08	0.10	0.13	0.06	0.10	0.14	0.18	0.21	0.09	0.16	0.23	0.30	0.35	0.30	0.54	0.72	0.99	0.30	0.54	0.72	0.99	0.30	0.54	0.72	0.99										
Rated Speed 2000 (rpm)	Kt (Nm/A) 1.20																																								
Ke(NOM) = 85.5 V/krpm	Ke (V/krpm) 73.3																																								
Rated Torque (Nm)	1.2	2.3	3.3	4.2	2.3	4.3	6.0	7.6	9.1	3.7	6.8	9.8	12.3	16.6	6.8	12.0	17.0	21.4	24.9	20.8	39.0	53.0	20.8	39.0	53.0	20.8	39.0	53.0	20.8	39.0	53.0										
Continuous Stall Current (A)	1.1	2.0	2.8	3.7	2.1	3.8	5.4	6.9	8.4	3.3	6.1	8.8	11.6	14.7	6.1	10.5	14.8	19.1	22.6	17.8	33.1	48.2	17.8	33.1	48.2	17.8	33.1	48.2	17.8	33.1	48.2										
Rated Power (kW)	0.25	0.48	0.69	0.88	0.48	0.90	1.26	1.59	1.91	0.77	1.42	2.05	2.58	3.48	1.42	2.51	3.56	4.48	5.22	4.36	8.17	11.1	4.36	8.17	11.1	4.36	8.17	11.1	4.36	8.17	11.1										
R (ph-ph) (Ohms)	45.8	15.3	8.52	5.72	19.4	6.2	3.16	2.31	1.71	9.09	2.83	1.51	0.99	0.82	4.28	1.33	0.76	0.45	0.32	0.50	0.15	0.10	0.50	0.15	0.10	0.50	0.15	0.10	0.50	0.15	0.10										
L (ph-ph) (mH)	98.8	43.4	27.9	20.2	59.2	25.8	16.0	12.6	10.1	47.3	20.6	13.1	9.54	7.86	33.7	15.1	10.30	6.96	5.58	7.98	3.32	2.73	7.98	3.32	2.73	7.98	3.32	2.73	7.98	3.32	2.73										
Rated Speed 3000 (rpm)	Kt (Nm/A) 0.80																																								
Ke(NOM) = 57 V/krpm	Ke (V/krpm) 48.8																																								
Rated Torque (Nm)	1.2	2.2	3.1	3.9	2.2	4.2	5.9	7.5	9.0	3.3	6.2	9.2	11.9	14.7	6.3	10.5	14.2	▲	N/A	20.1	36.2	N/A	N/A	20.1	36.2	N/A	N/A	20.1	36.2	N/A	N/A										
Continuous Stall Current (A)	1.6	3.0	4.3	5.5	3.1	5.8	8.2	10.4	12.5	5.0	9.2	13.2	17.4	22.1	9.2	15.7	22.2	▲	N/A	26.7	49.7	N/A	N/A	26.7	49.7	N/A	N/A	26.7	49.7	N/A	N/A										
Rated Power (kW)	0.38	0.69	0.97	1.23	0.69	1.32	1.85	2.36	2.83	1.04	1.95	2.89	3.74	4.62	1.98	3.30	4.46	▲	N/A	6.31	11.4	N/A	N/A	6.31	11.4	N/A	N/A	6.31	11.4	N/A	N/A										
R (ph-ph) (Ohms)	18.9	6.26	3.50	2.38	8.03	2.68	1.57	1.03	0.77	4.01	1.30	0.73	0.47	0.37	1.90	0.59	0.31	▲	N/A	0.25	0.08	N/A	N/A	0.25	0.08	N/A	N/A	0.25	0.08	N/A	N/A										
L (ph-ph) (mH)	42.5	18.4	11.9	8.82	25.6	12.0	7.91	5.60	4.65	20.1	9.16	6.07	4.26	3.49	15.0	6.85	4.20	▲	N/A	3.98	1.87	N/A	N/A	3.98	1.87	N/A	N/A	3.98	1.87	N/A	N/A										
Rated Speed 4000 (rpm)	Kt (Nm/A) 0.62																																								
Ke(NOM) = 44.0 V/krpm	Ke (V/krpm) 37.7																																								
Rated Torque (Nm)	1.1	1.9	2.6	3.3	2.0	3.2	4.4	5.5	6.6	2.9	5.4	7.3	8.6	N/A	4.2	8.2	N/A	N/A	N/A	20.1	36.2	N/A	N/A	20.1	36.2	N/A	N/A	20.1	36.2	N/A	N/A										
Continuous Stall Current (A)	2.1	3.9	5.5	7.1	4.1	7.5	10.6	13.5	16.2	6.5	11.9	17.1	22.6	N/A	11.9	20.3	N/A	N/A	N/A	26.7	49.7	N/A	N/A	26.7	49.7	N/A	N/A	26.7	49.7	N/A	N/A										
Rated Power (kW)	0.46	0.80	1.09	1.38	0.84	1.34	1.84	2.30	2.76	1.21	2.26	3.06	3.60	N/A	1.76	3.43	N/A	N/A	N/A	6.31	11.4	N/A	N/A	6.31	11.4	N/A	N/A	6.31	11.4	N/A	N/A										
R (ph-ph) (Ohms)	10.2	3.39	1.92	1.48	5.15	1.64	0.92	0.62	0.43	2.62	0.82	0.44	0.29	N/A	1.20	0.36	N/A	N/A	N/A	0.25	0.08	N/A	N/A	0.25	0.08	N/A	N/A	0.25	0.08	N/A	N/A										
L (ph-ph) (mH)	24.6	10.8	7.14	5.42	15.5	6.77	4.61	3.46	2.54	12.6	5.48	3.57	2.53	N/A	9.45	4.08	N/A	N/A	N/A	3.98	1.87	N/A	N/A	3.98	1.87	N/A	N/A	3.98	1.87	N/A	N/A										
Rated Speed 6000 (rpm)	Kt (Nm/A) 0.40																																								
Ke(NOM) = 28.5 V/krpm	Ke (V/krpm) 24.4																																								
Rated Torque (Nm)	1.0	1.8	2.4	3.0	1.7	2.7	3.7	4.8	▲	2.7	4.7	▲	N/A	N/A	3.6	▲	N/A	N/A	N/A	20.1	36.2	N/A	N/A	20.1	36.2	N/A	N/A	20.1	36.2	N/A	N/A										
Continuous Stall Current (A)	3.3	6.0	8.5	11.0	6.3	11.5	16.3	20.8	▲	10.0	18.3	▲	N/A	N/A	18.3	▲	N/A	N/A	N/A	26.7	49.7	N/A	N/A	26.7	49.7	N/A	N/A	26.7	49.7	N/A	N/A										
Rated Power (kW)	0.63	1.13	1.51	1.88	1.07	1.70	2.32	3.02	▲	1.70	2.95	▲	N/A	N/A	2.26	▲	N/A	N/A	N/A	6.31	11.4	N/A	N/A	6.31	11.4	N/A	N/A	6.31	11.4	N/A	N/A										
R (ph-ph) (Ohms)	4.49	1.49	0.95	0.65	2.01	0.67	0.35	0.26	▲	0.96	0.30	▲	N/A	N/A	0.49	▲	N/A	N/A	N/A	0.25	0.08	N/A	N/A	0.25	0.08	N/A	N/A	0.25	0.08	N/A	N/A										
L (ph-ph) (mH)	10.7	4.73	3.10	2.33	6.41	3.01	1.77	1.40	▲	4.80	2.09	▲	N/A	N/A	3.96	▲	N/A	N/A	N/A	3.98	1.87	N/A	N/A	3.98	1.87	N/A	N/A	3.98	1.87	N/A	N/A										

▲ Consult factory
 N/A Not available
 The information contained in this specification is for guidance only and does not form part of any contract.
 CT Dynamics Limited have an ongoing process of development and reserve the right to change the specification without notice.

How To Use Torque-Speed Curves

The performance graphs contained in this section are applicable to both standard and UL motors. Each torque-speed graph depicts limits of operation for a given motor.

Limits of operation are shown for three categories; -

1. Continuous (or RMS)
2. Intermittent (short term)
3. Speed limit

Circumstances often require de-rating of motor or drive, see "Motor De-rating" and "Test conditions"

Continuous or RMS Torque Limit (1)

Two levels of continuous operation are shown, one for encoder motors where the maximum permitted winding temperature rise $\Delta t = 100^{\circ}\text{C}$; and one for resolver motors where $\Delta t = 125^{\circ}\text{C}$.

RMS means Root Mean Square (see section 12) and gives the effective continuous torque compatible with repetitive torque sequences. (Most servo applications will have a repeatable sequence of events, e.g. accelerate, run, decelerate, and pause).

Continuous / RMS torque level must be in the area depicted Continuous Zone, otherwise the motor will exceed the Δt limit and may overheat.

Intermittent / Peak Torque Limit (2)

Above the Continuous zone is an Intermittent Zone where the motor may be safely operated for short periods of time. Operation within the Intermittent Zone is permissible provided that $\Delta t < 100^{\circ}\text{C}$ or $\Delta t < 125^{\circ}\text{C}$, in accordance with the motor type rating.

Maximum peak torque is the upper limit of the Intermittent Zone and is given by :-

$$\text{Peak Torque (max)} = 3 \times \text{Stall Torque rating for } \Delta t = 100^{\circ}\text{C}.$$

Maximum Δt limit must not be exceeded at any time.

Periods of a motor's operating sequence may include frequent excursions into the Intermittent Zone. A very common reason for this is for fast acceleration and deceleration where torque levels approaching peak torque may be required.

Speed Limit (3)

To the right of the graph is a sloping line depicting the maximum motor speed for a 400V drive supply. For EZ motors, this line corresponds to 230V drive supply.

This speed limit line is dependent upon the motor winding; the winding current and frequency, and the voltage supply to the drive.

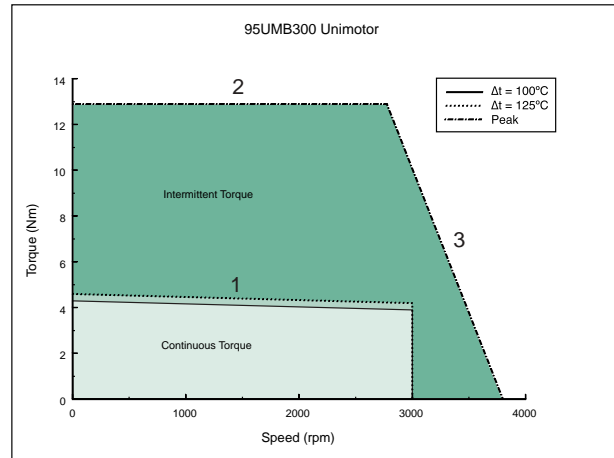

How to use Torque-Speed Graphs

- (1) Continuous torque limit
- (2) Peak torque limit
- (3) Speed limit

If, at 400V supply, the speed is increased beyond the limit shown, the motor sinusoidal waveform shall have insufficient voltage and will clip and distort, causing inefficiency and higher temperatures. If the distortion is increased further, the drive may lose control of the motor and trip.

For higher supply voltages, motor speed limit increases, and for lower supply voltages, motor speed limit decreases.

Motors With 4096 ppr Encoders - Unidrive inhibits Speed demands $> 3660\text{rpm}^*$

Motors With 2048 ppr Encoders - Unidrive inhibits Speed demands $> 7320\text{rpm}^*$

* Applicable Unidrive 3.1.7 s/w onwards

Caution: Because of the high voltages generated, motors should never be back-driven at speeds $>$ quoted maximum speed.

Plotting an Operating Point

To estimate whether a motor is the correct choice for a given system, it is necessary to calculate or measure the RMS torque and the RMS speed for a given system in its normal continual stop/ start sequenced mode. This Operating Point may be marked on the torque-speed graph.

If RMS torque is below motor rated torque there will be no need to consider RMS speed.

If this point lies well within the Continuous Zone, then the motor is suitable for the application.

The permitted duration of the excursion into the intermittent area will depend upon the winding thermal time-constant of the motor and the immediate previous thermal history of events (i.e. the motor winding temperature at the beginning of the excursion). In certain circumstances the duration of the

excursion). In certain circumstances the duration of the excursion can be many minutes because the winding thermal time-constant for larger motors may be quite long. The drive is equipped with suitable software to estimate the thermal effects of the motors activities, based on current and time. It is therefore important that the drive has the correct thermal time-constant value entered as a parameter.

When sizing a motor based upon load calculations for a system, it is advisable to allow for a contingency factor of at least 15%.

All motor performance data is subject to a tolerance of +/- 10%.

Motor De-rating

The performance data shown corresponds to 40°C maximum ambient (surrounding air temperature) and the drive switching frequencies shown in table 1.

Motor type	Switching Frequency
75A to 142E	12kHz
190A to 190D	9kHz

Table 1. Switching Frequencies for Performance Data

Drive supply: 415V, 3 phase nominal.

The P.I.D. parameters are set so that the motor draws minimal current at no load. Differential Gain = 0. Proportional and Integral Gains are set for smooth running and minimised speed overshoot under fast acceleration.

A lower switching frequency other than as shown in Table 1 or any other adverse operating condition requires that the motor performance be de-rated.

Such circumstances include:

- Lower switching frequency setting of the drive, (i.e. < 12kHz for 75 – 142mm frame; < 9kHz for 190mm frame), see table 2.
 - ambient temperatures > 40°C
 - confined space / restricted natural air flow
 - inadequate thermal path for motor mounting
 - motor mounted to a gearbox
 - drive oversize for motor
- For motor switching frequency de-rating, see Table 2
- Most Unidrive nominal current ratings are reduced, for the higher switching frequencies, see Unidrive manuals for de-rating tables. As a consequence of this, there can be a cost optimisation for the choice of motor-drive match and

the choice of switching frequency.

Conversely, lower temperatures or forced air-cooling can improve continuous ratings only (not peak torque).

If heating effects justify, the Unidrive automatically halves the switching frequency (from 6, 9 or 12 kHz) to protect the IGBTs. This will increase motor dissipation and allowance should be made if such circumstance is likely.

When selecting an SP Unidrive to match a servo motor, use 'Heavy Duty' drive ratings, unless only a menial continuous function at < 50% of motor speed is required.

Switching frequency de-rating for UM MOTORS with respect to performance tables.

Table 2 Motor De-rate factor for drive switching frequency

Motor	12 kHz	9 kHz	6 kHz	4.5 kHz	3 kHz
75A	1	0.99	0.98	0.97	0.96
75B	1	0.99	0.97	0.96	0.95
75C	1	0.98	0.96	0.95	0.94
75D	1	0.98	0.95	0.94	0.93
95A	1	1.00	0.98	0.97	0.95
95B	1	0.99	0.97	0.95	0.93
95C	1	0.99	0.96	0.94	0.91
95D	1	0.98	0.95	0.92	0.89
95E	1	0.97	0.93	0.91	0.88
115A	1	0.99	0.97	0.96	0.94
115B	1	0.98	0.95	0.93	0.91
115C	1	0.97	0.93	0.91	0.89
115D	1	0.96	0.92	0.89	0.86
115E	1	0.95	0.90	0.87	0.84
142A	1	0.99	0.98	0.97	0.96
142B	1	0.98	0.96	0.94	0.91
142C	1	0.97	0.94	0.91	0.87
142D	1	0.97	0.91	0.88	0.84
142E	1	0.96	0.89	0.86	0.81
190A	N/A	1	0.99	0.99	0.98
190B	N/A	1	0.98	0.97	0.95
190C	N/A	1	0.97	0.94	0.91
190D	N/A	1	0.94	0.90	0.85

E.g For a 115 UMC 300 with resolver feedback run at 9kHz

Stall torque = $10.5 \times 0.97 = 10.2\text{Nm}$

Rated torque = $9.2 \times 0.97 = 8.9\text{Nm}$

Thermal Test conditions

The tests were carried at an ambient of 25°C.

The motor under test mounted on a thermally isolated aluminium plate of dimensions as per Table 3 below.

Motor type	Aluminium Heatsink plate
75 – 95 mm	250 x 250 x 15 mm
115 – 142 mm	350 x 350 x 20 mm
190 mm	500 x 500 x 20 mm

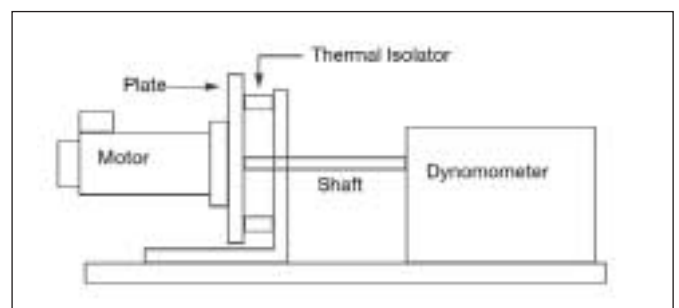
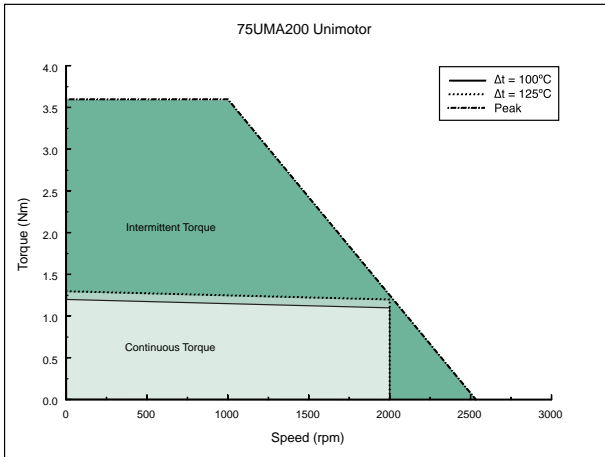

Table 3

5

75/2000 RPM

75UMA200 Unimotor



75UMD200 Unimotor

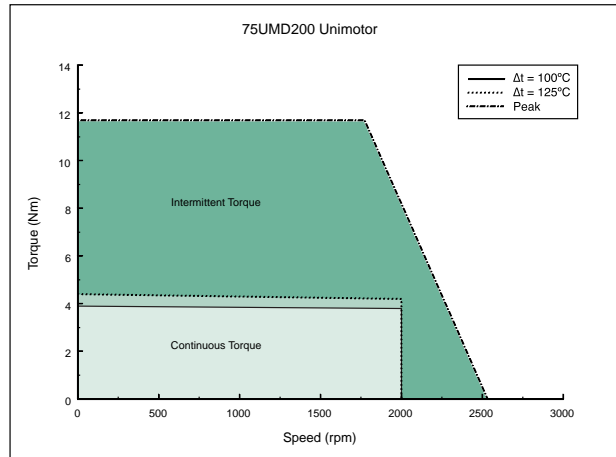

75UMB200 Unimotor

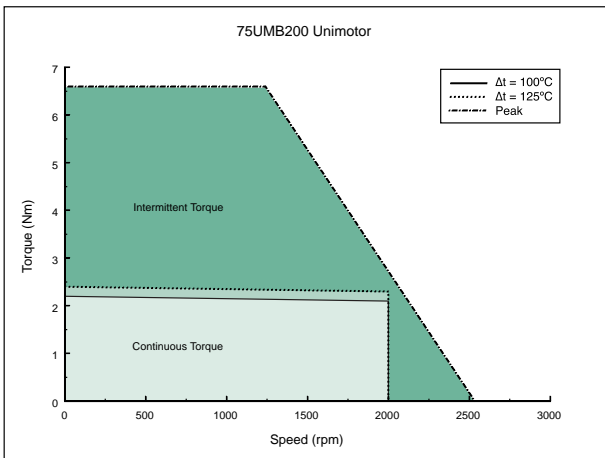

75UMC200 Unimotor

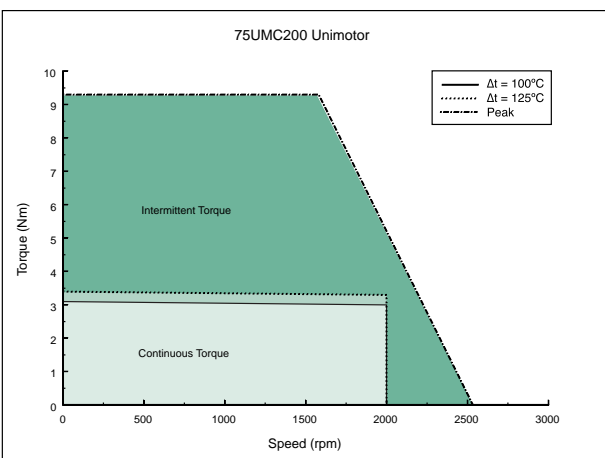

All graphs are at 40°C ambient and 400Vac drive supply
How to use torque-speed graphs see pages 2,3 & 4.

95/2000 RPM

95UMA200 Unimotor

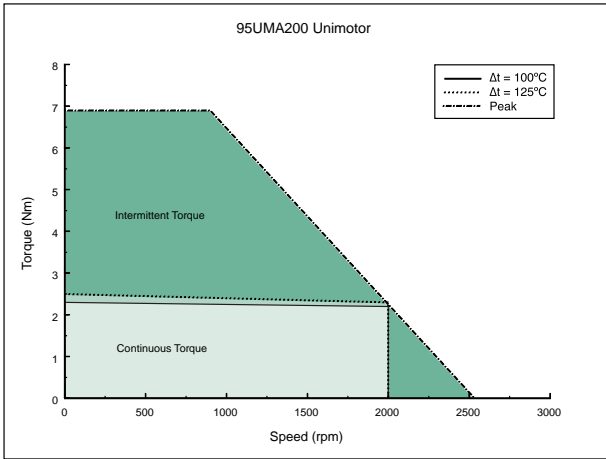

95UMD200 Unimotor

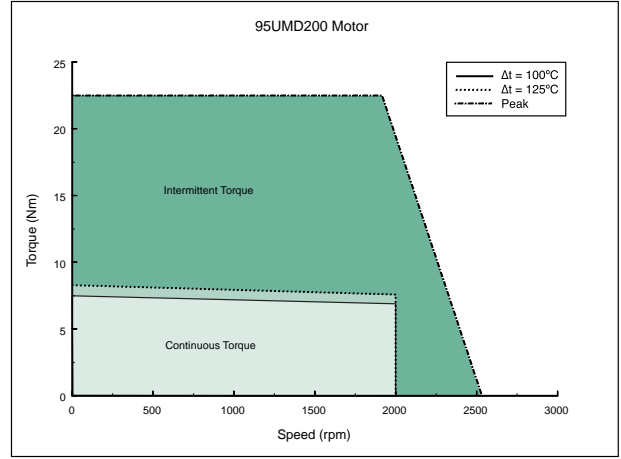

95UMB200 Unimotor

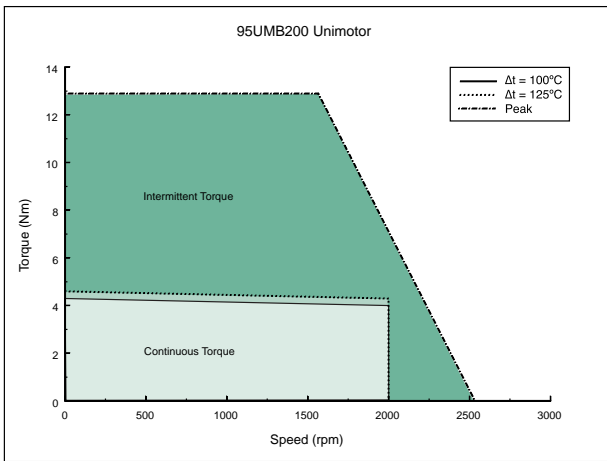

95UME200 Unimotor

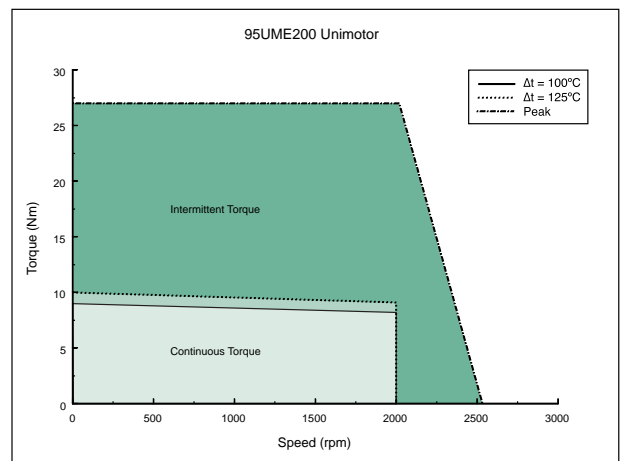

95UMC200 Unimotor

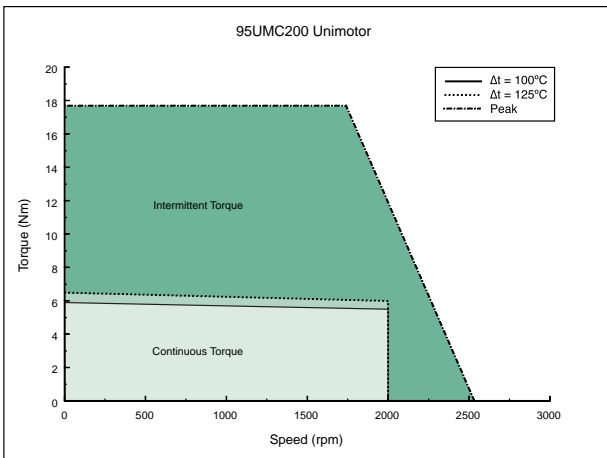

All graphs are at 40°C ambient and 400Vac drive supply
How to use torque-speed graphs see pages 2,3 & 4.

5

5-5

115/2000 RPM

115UMA200 Unimotor

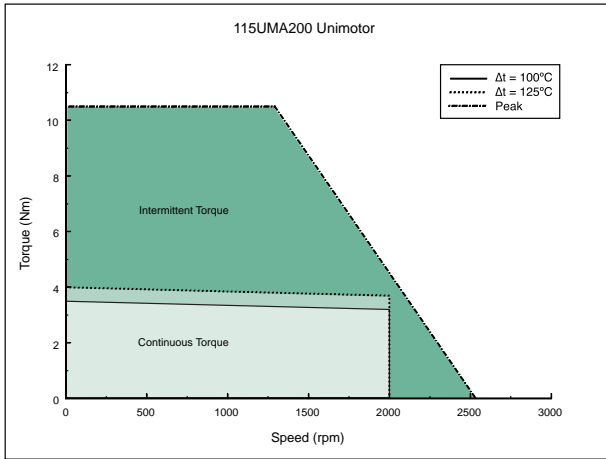

115UMD200 Unimotor

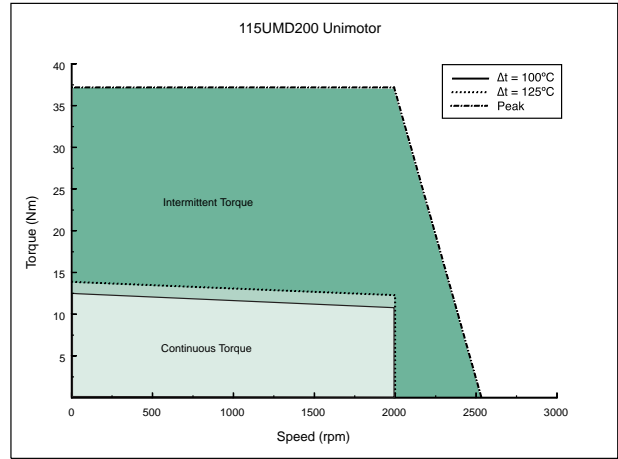

115UMB200 Unimotor

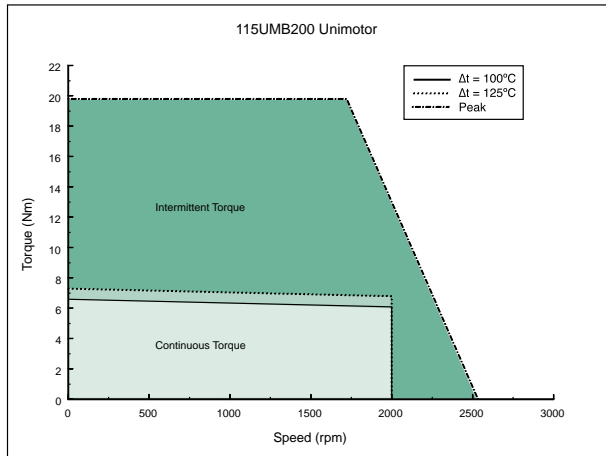

115UME200 Unimotor

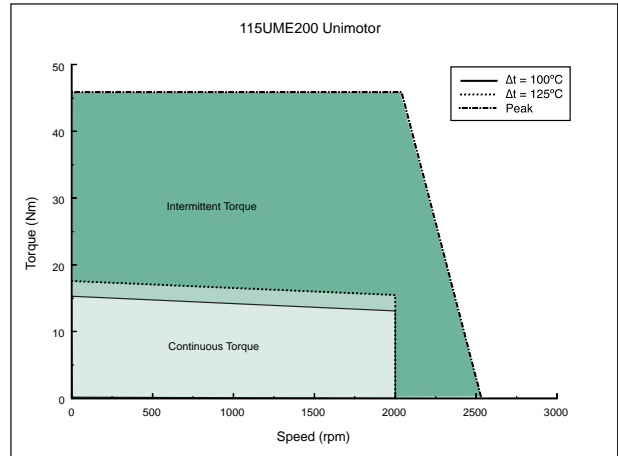

115UMC200 Unimotor

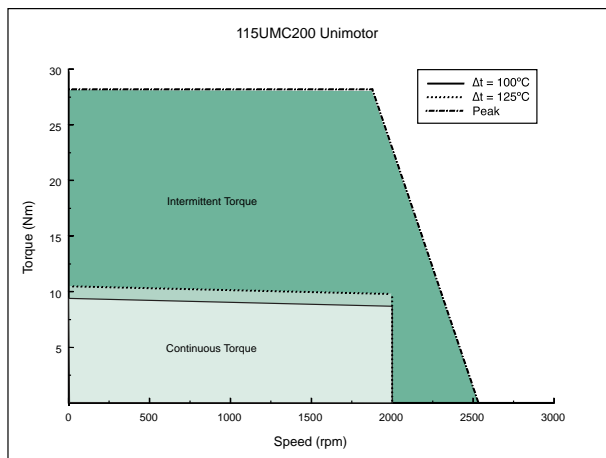

All graphs are at 40°C ambient and 400Vac drive supply
How to use torque-speed graphs see pages 2,3 & 4.

142/2000 RPM

142UMA200 Unimotor

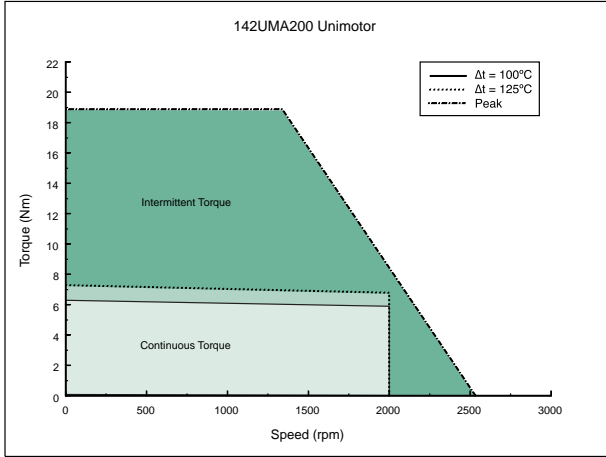

142UMD200 Unimotor

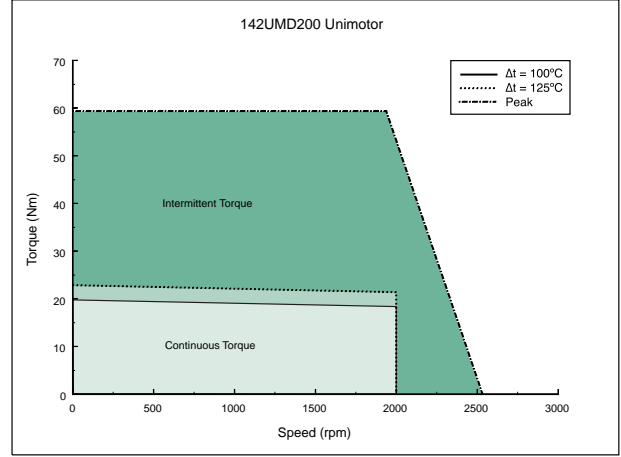

142UMB200 Unimotor

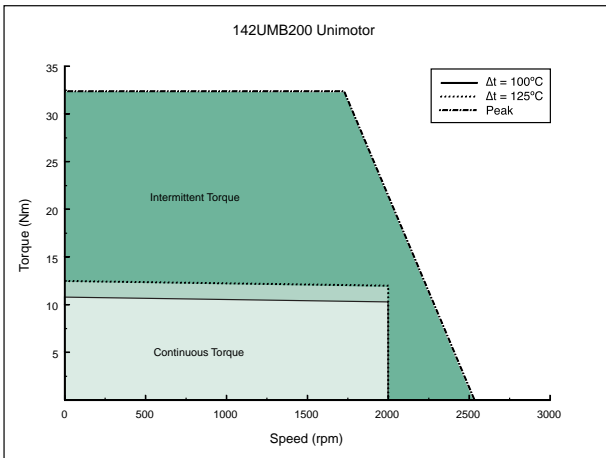

142UME200 Unimotor

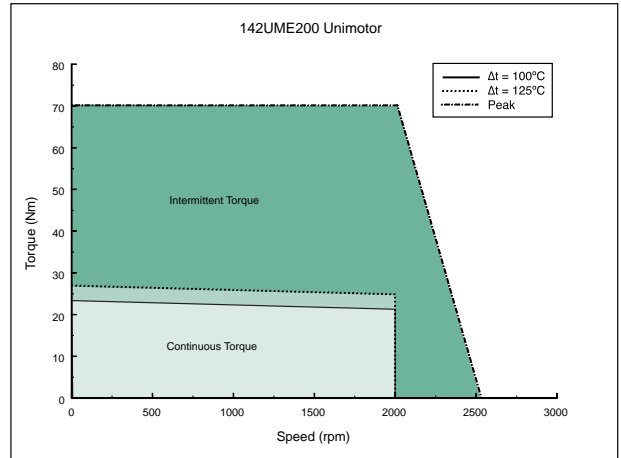

142UMC200 Unimotor

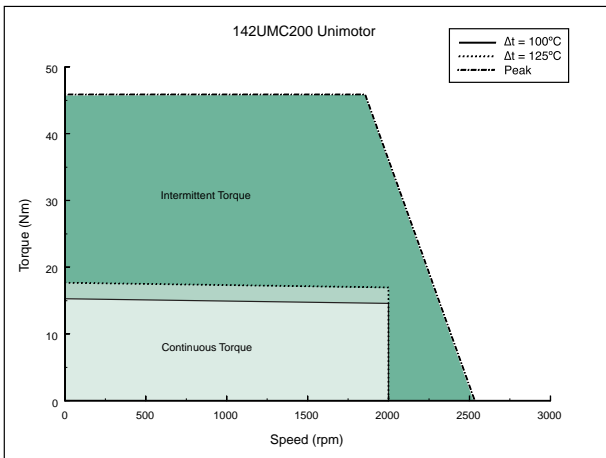

All graphs are at 40°C ambient and 400Vac drive supply
How to use torque-speed graphs see pages 2,3 & 4.

190/2000 RPM

190UMA200 Unimotor

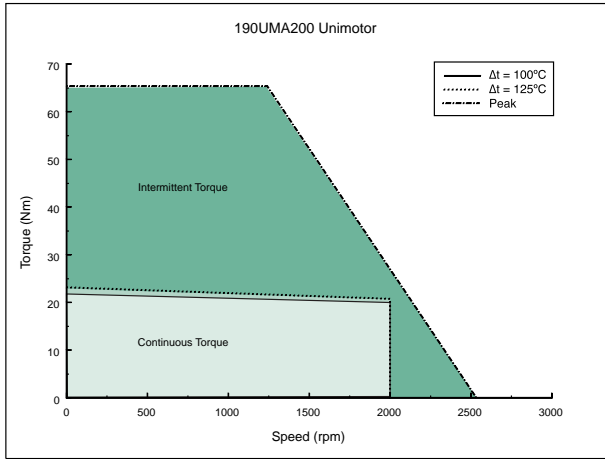

190UMD200 Unimotor

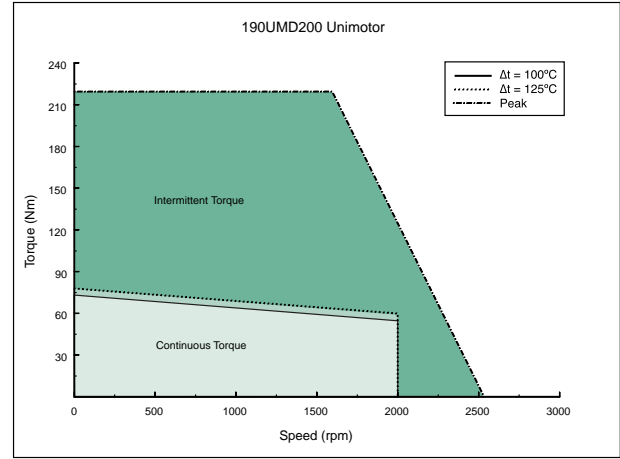

190UMB200 Unimotor

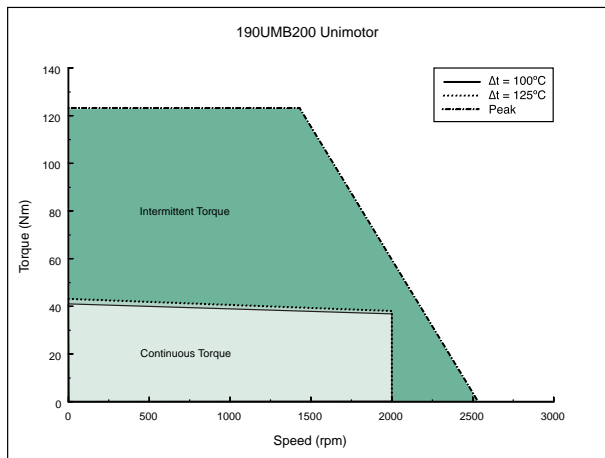

190UMC200 Unimotor

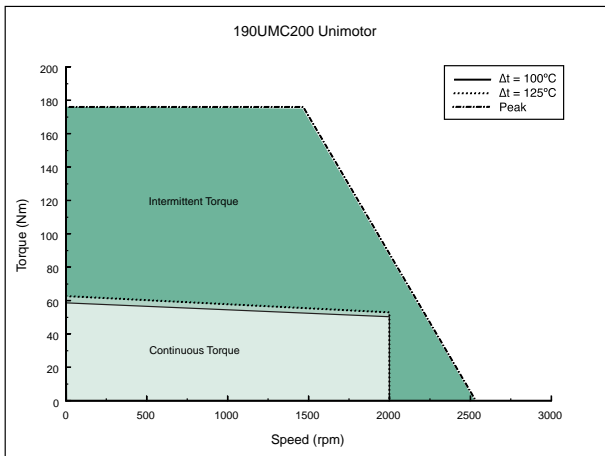

All graphs are at 40°C ambient and 400Vac drive supply
How to use torque-speed graphs see pages 2,3 & 4.

75/3000 RPM

75UMA300 Unimotor

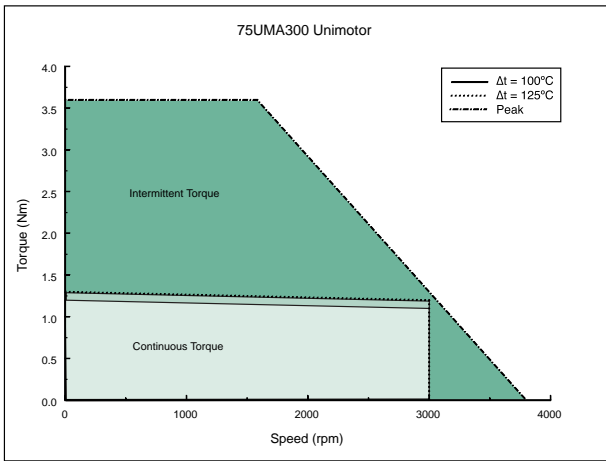

75UMD300 Unimotor

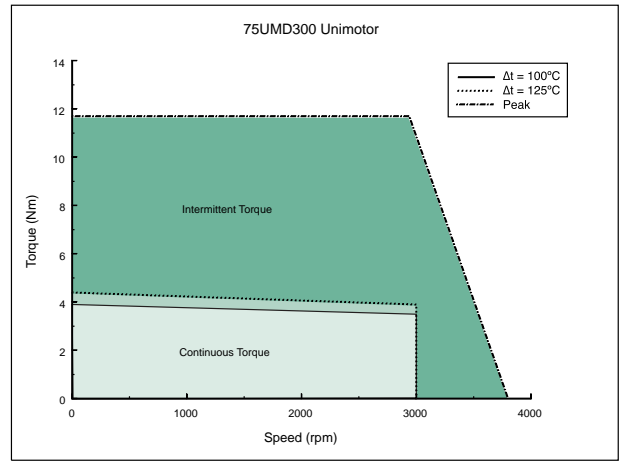

75UMB300 Unimotor

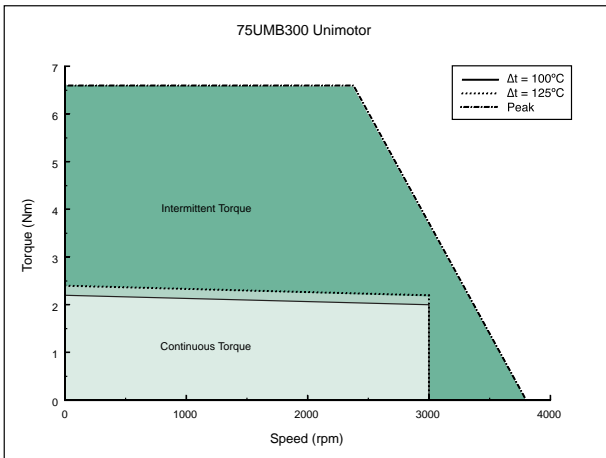

75UMC300 Unimotor

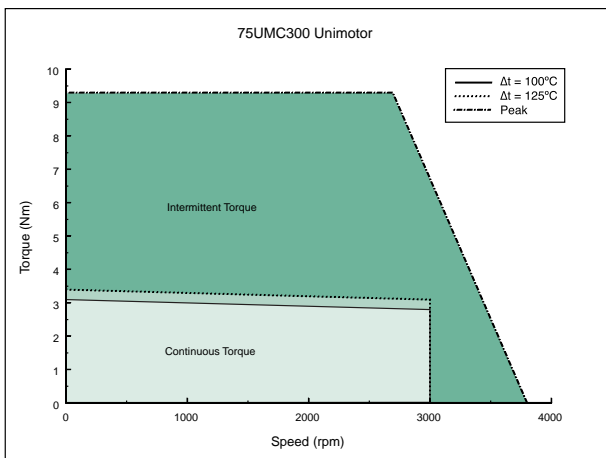

All graphs are at 40°C ambient and 400Vac drive supply
How to use torque-speed graphs see pages 2,3 & 4.

5

5-9

95/3000 RPM

95UMA300 Unimotor

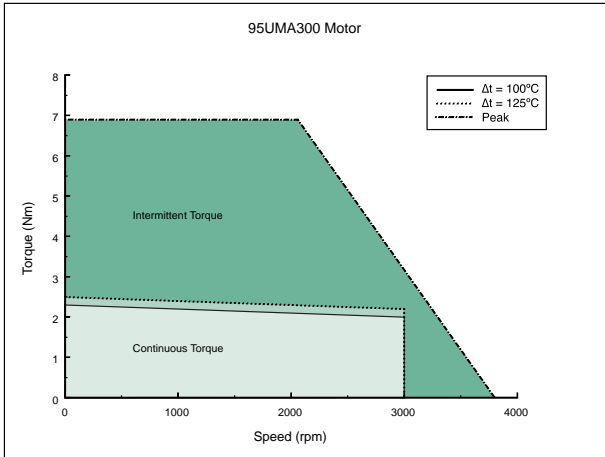

95UMD300 Unimotor

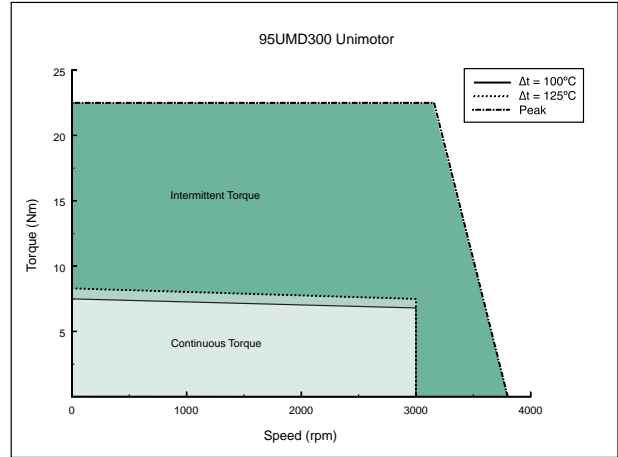

95UMB300 Unimotor

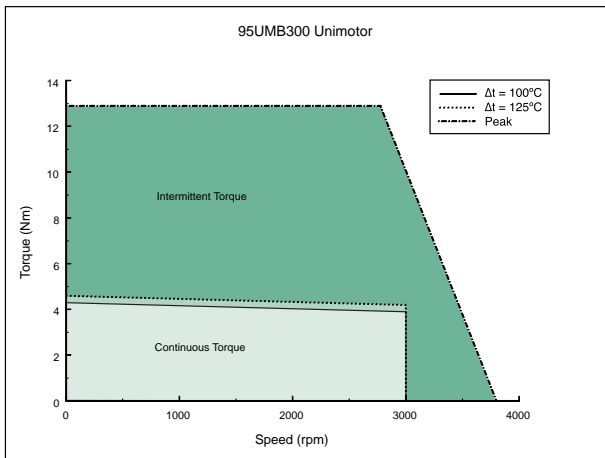

95UME300 Unimotor

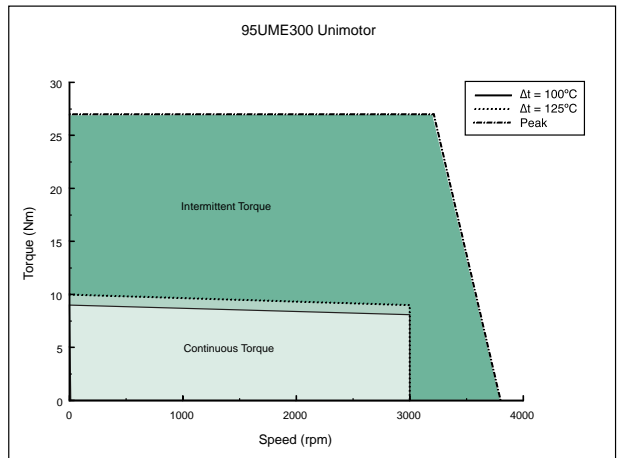

95UMC300 Unimotor

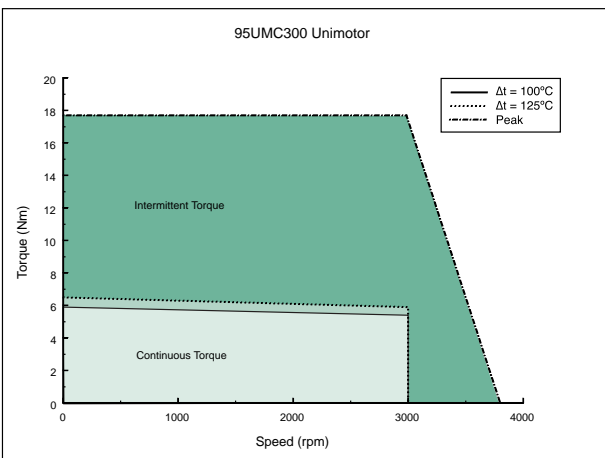

All graphs are at 40°C ambient and 400Vac drive supply
How to use torque-speed graphs see pages 2,3 & 4.

115/3000 RPM

115UMA300 Unimotor

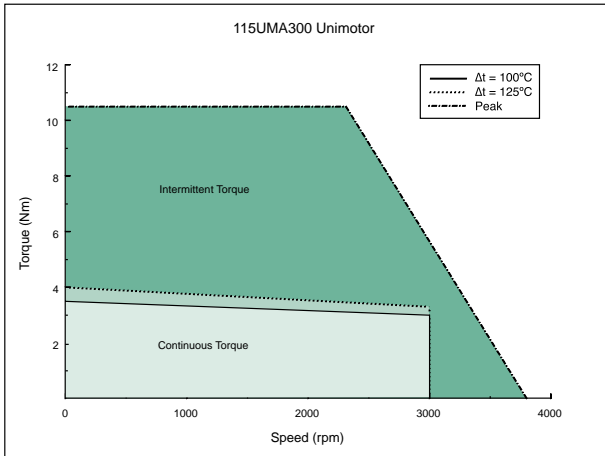

115UMD300 Unimotor

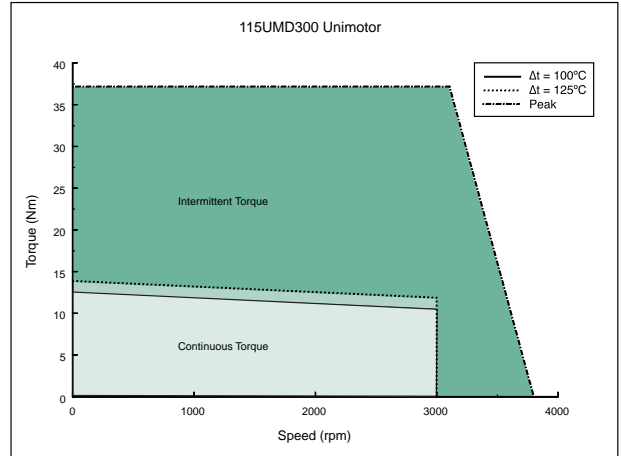

115UMB300 Unimotor

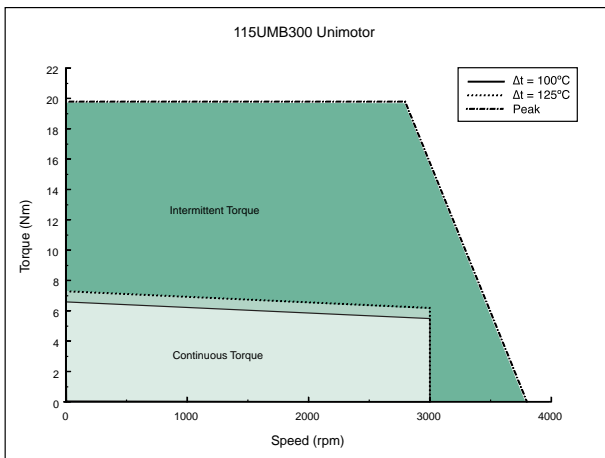

115UME300 Unimotor

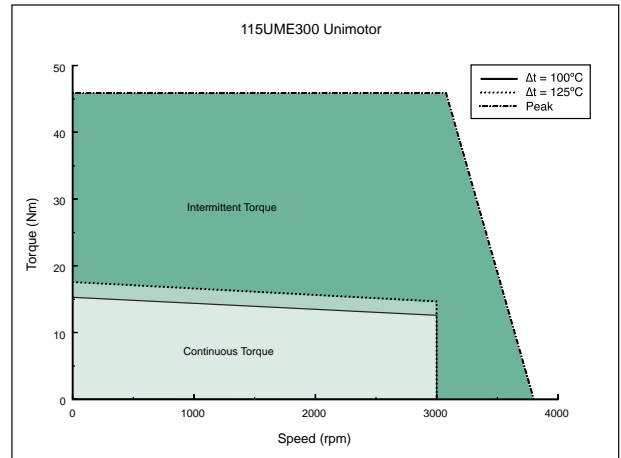

115UMC300 Unimotor

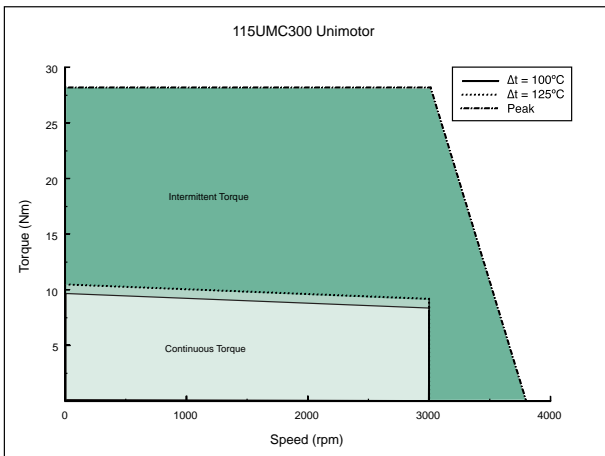

All graphs are at 40°C ambient and 400Vac drive supply
How to use torque-speed graphs see pages 2,3 & 4.

142/3000 RPM

142UMA300 Unimotor

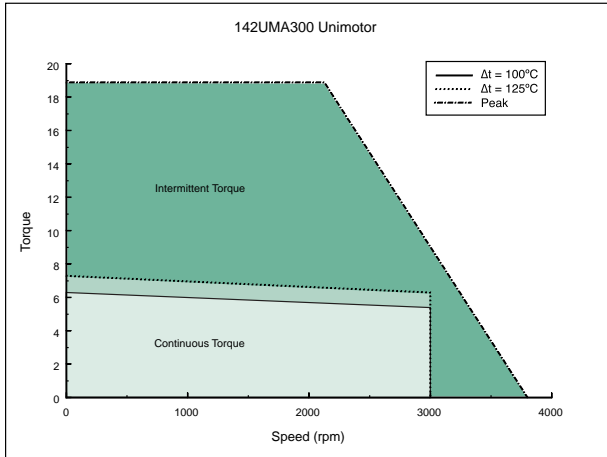

142UMD300 Unimotor

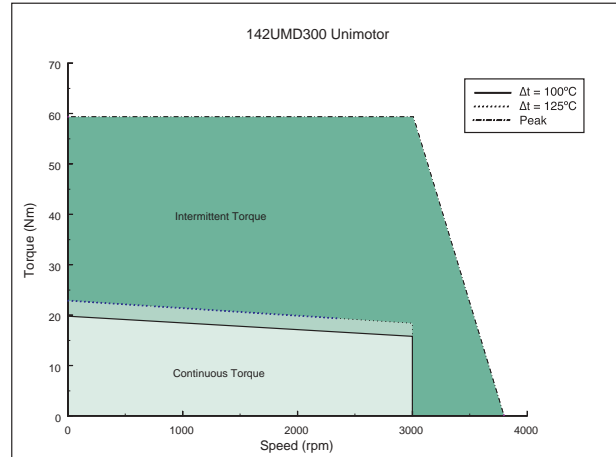

142UMB300 Unimotor

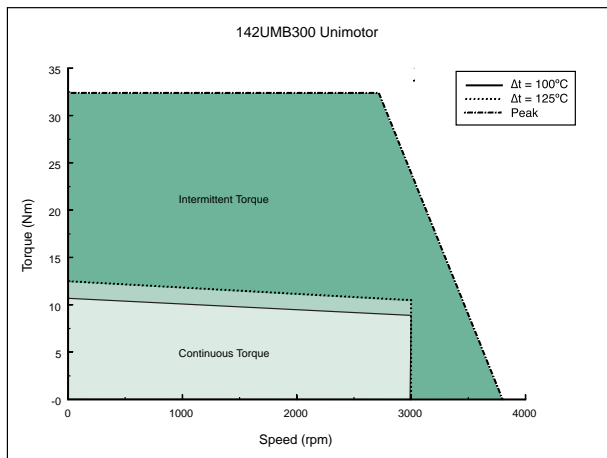

142UME300 Unimotor

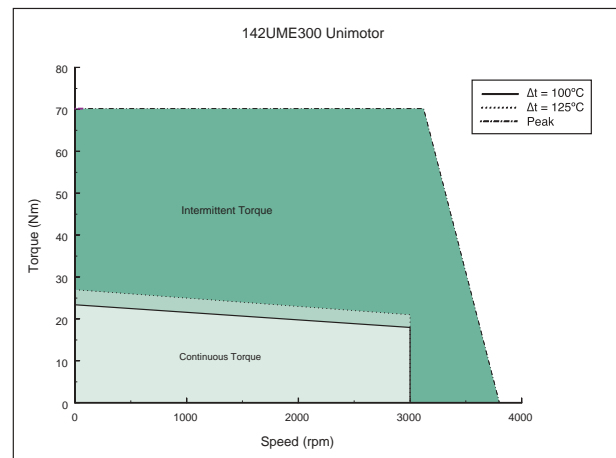

142UMC300 Unimotor

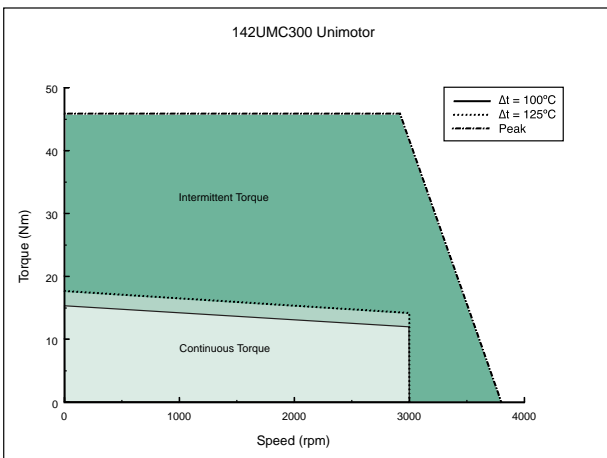

All graphs are at 40°C ambient and 400Vac drive supply
How to use torque-speed graphs see pages 2,3 & 4.

190/3000 RPM

190UMA300 Unimotor

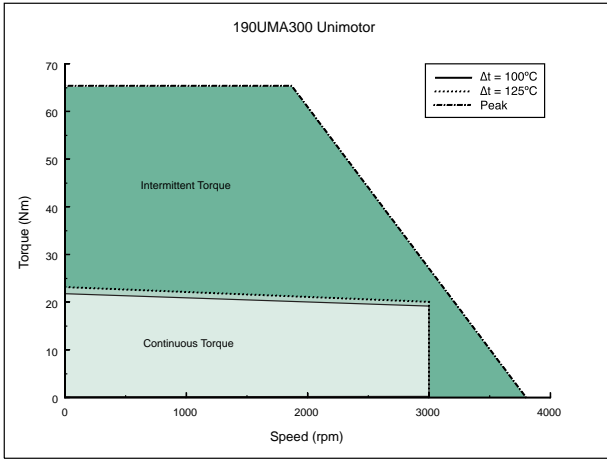

190UMD300 Unimotor

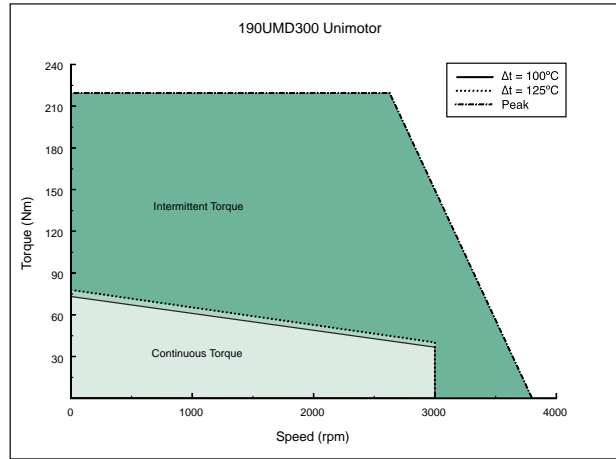

190UMB300 Unimotor

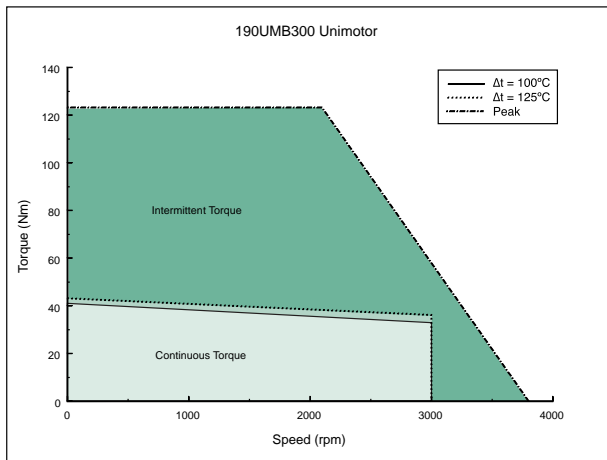

190UMC300 Unimotor

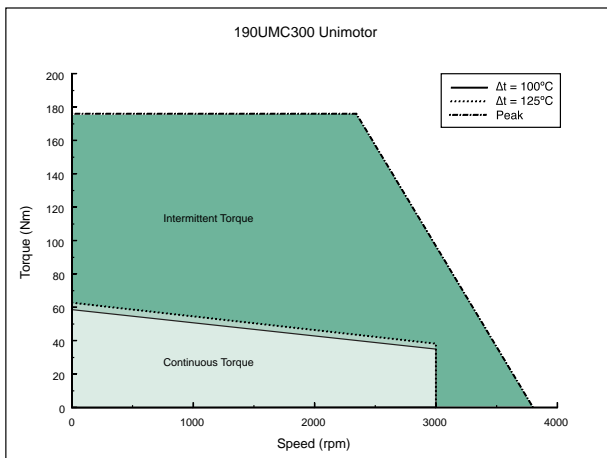

All graphs are at 40°C ambient and 400Vac drive supply
How to use torque-speed graphs see pages 2,3 & 4.

75/4000 RPM

75UMA400 Unimotor

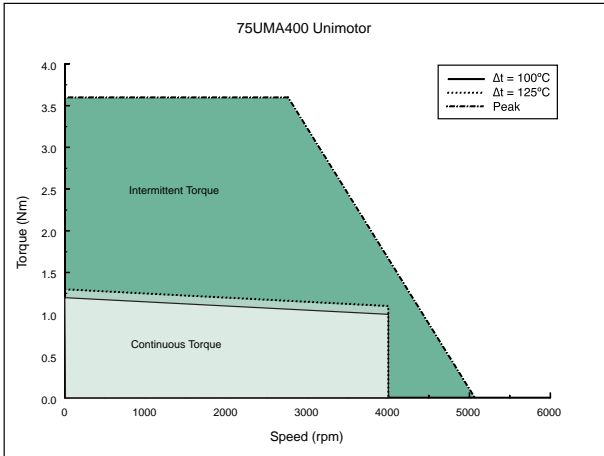

75UMD400 Unimotor

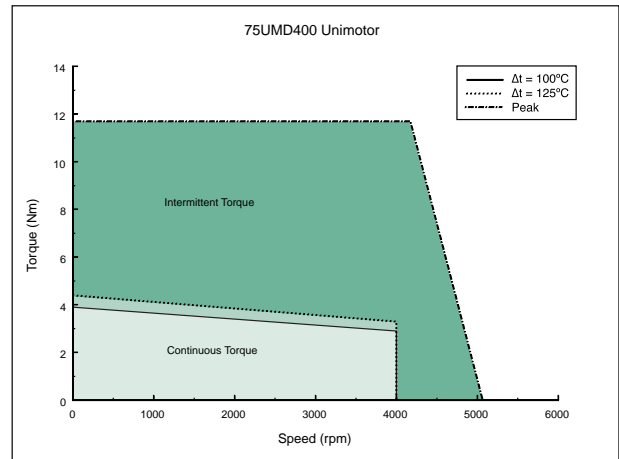

75UMB400 Unimotor

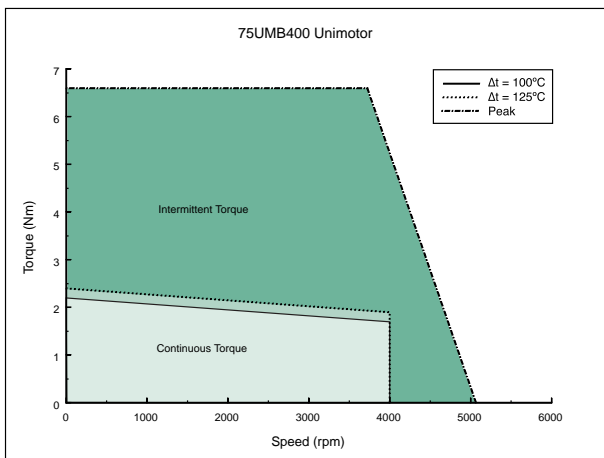

75UMC400 Unimotor

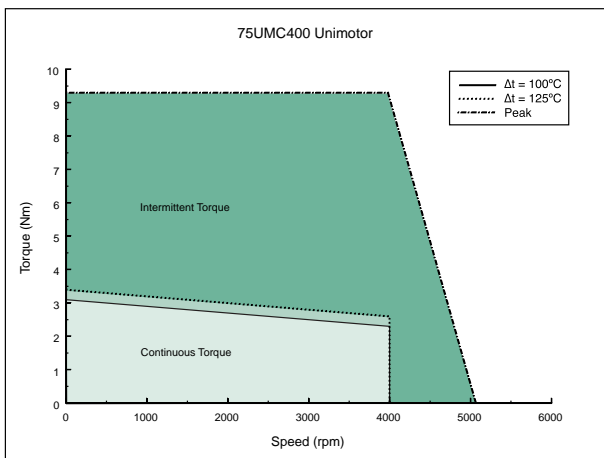

All graphs are at 40°C ambient and 400Vac drive supply
 How to use torque-speed graphs see pages 2,3 & 4.

95/4000 RPM

95UMA400 Unimotor

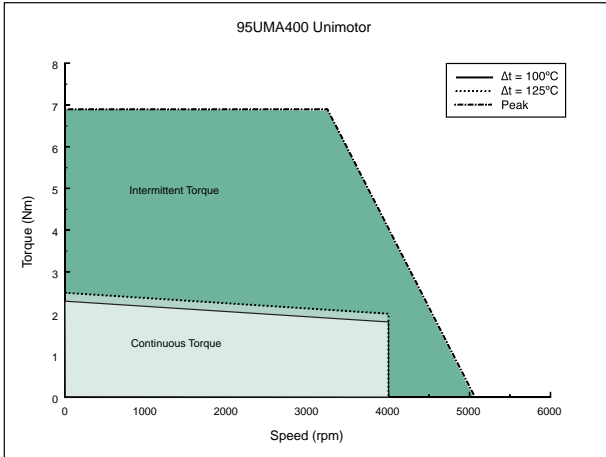

95UMD400 Unimotor

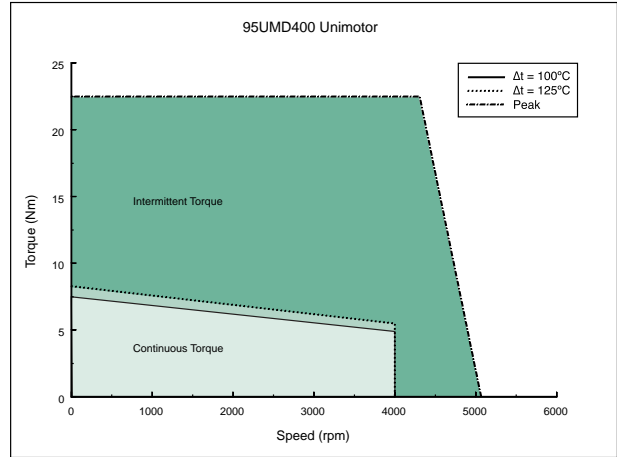

95UMB400 Unimotor

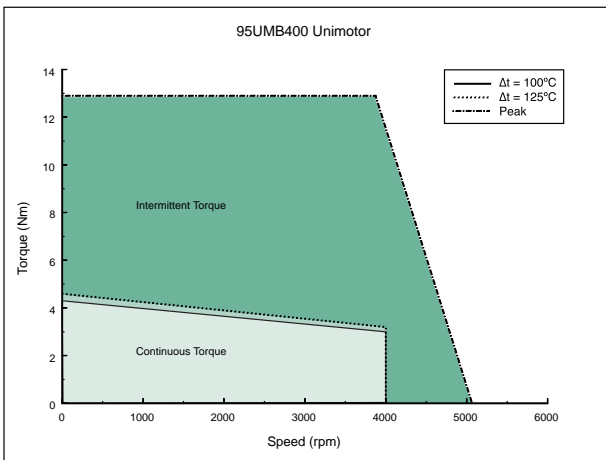

95UME400 Unimotor

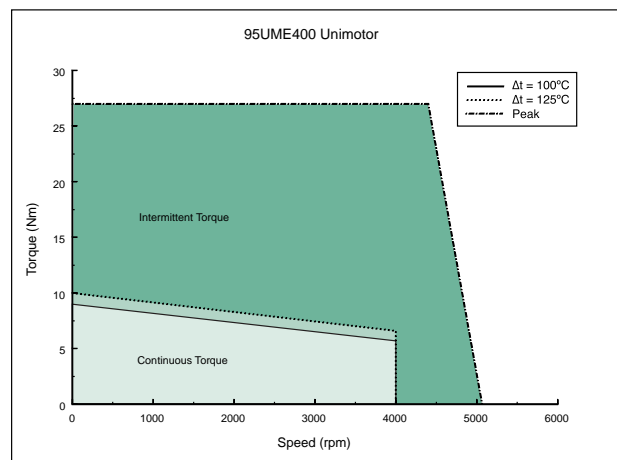

95UMC400 Unimotor

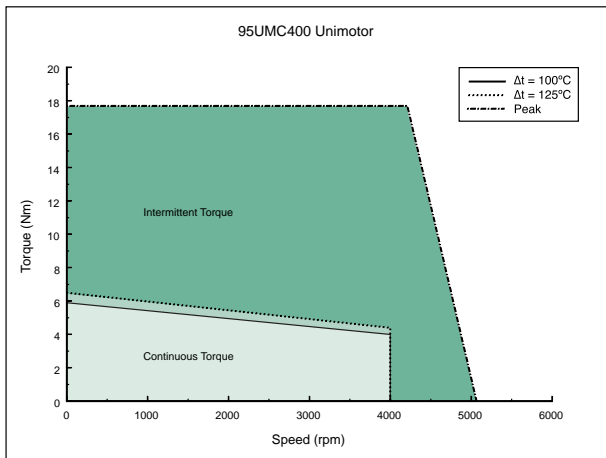

All graphs are at 40°C ambient and 400Vac drive supply
How to use torque-speed graphs see pages 2,3 & 4.

115/4000 RPM

115UMA400 Unimotor

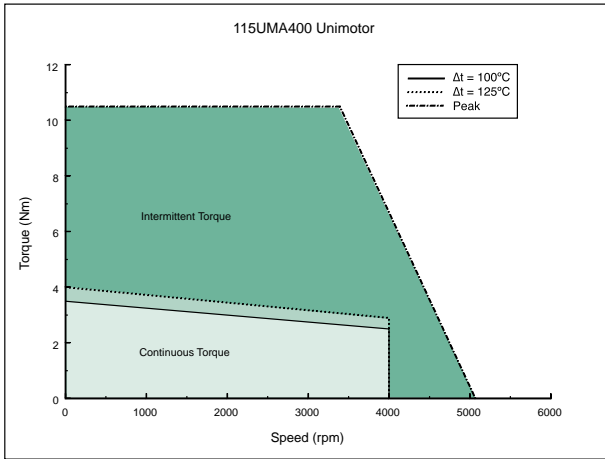

115UMD400 Unimotor

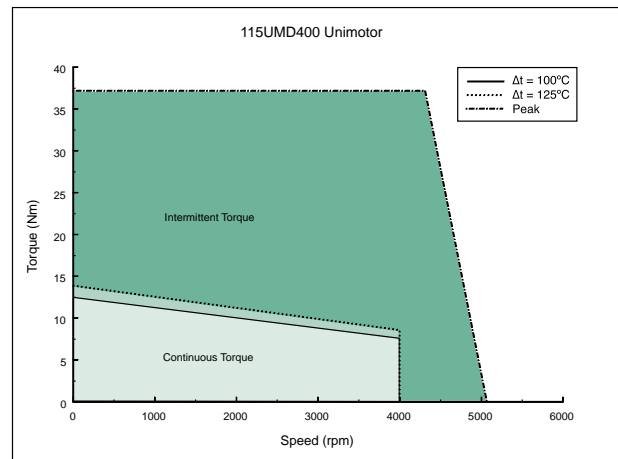

115UMB400 Unimotor

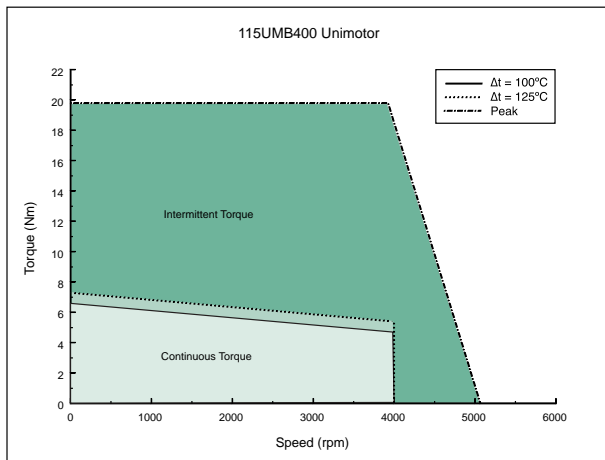

115UME400 Unimotor

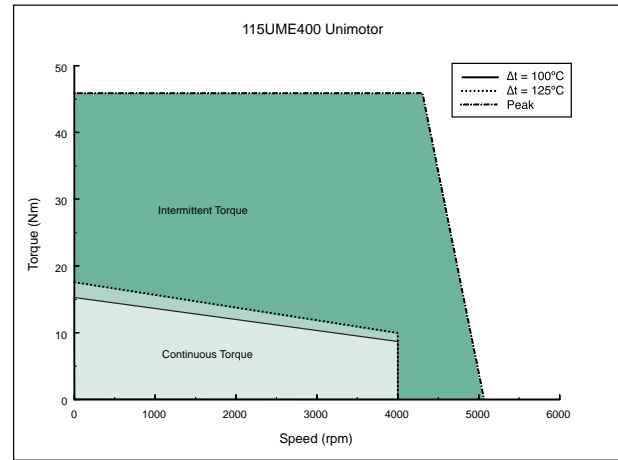

115UMC400 Unimotor

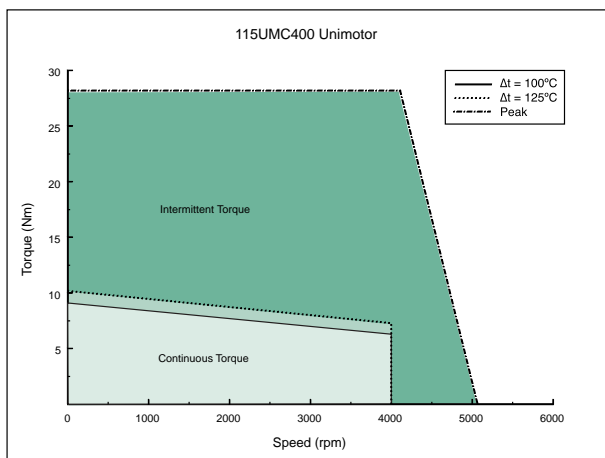

All graphs are at 40°C ambient and 400Vac drive supply
How to use torque-speed graphs see pages 2,3 & 4.

142/4000 RPM

1142UMA400 Unimotor

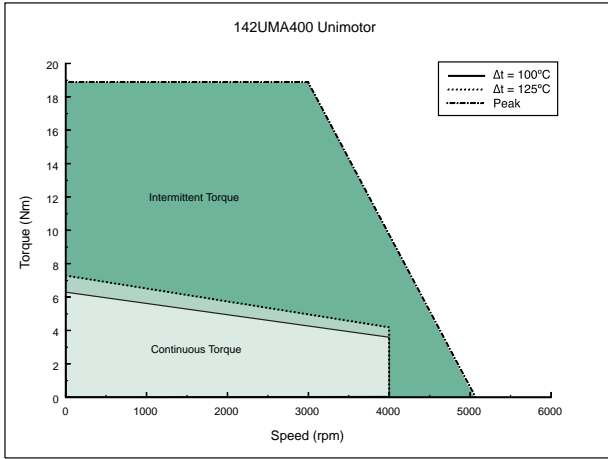

142UMD400 Unimotor

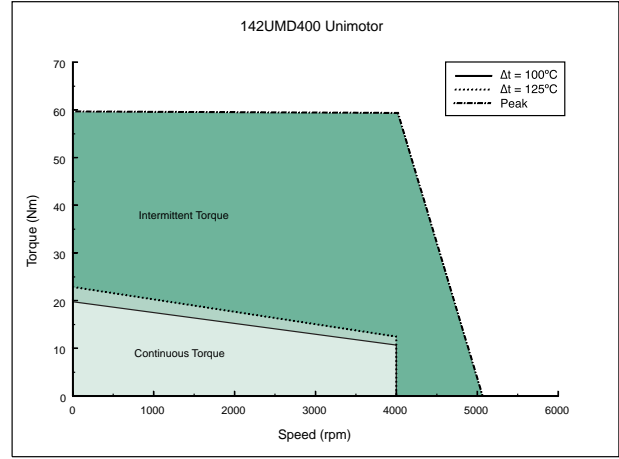

142UMB400 Unimotor

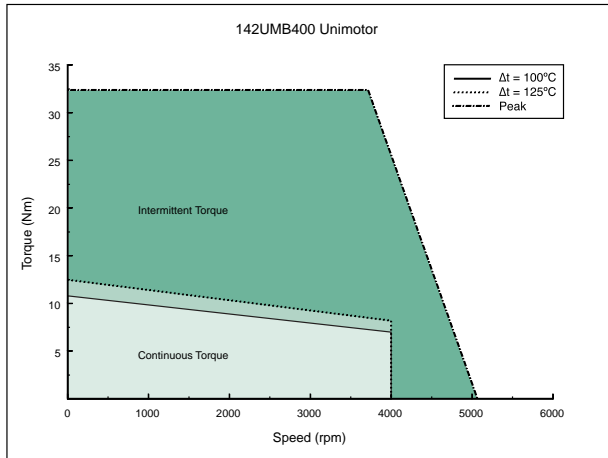

142UME400 Unimotor

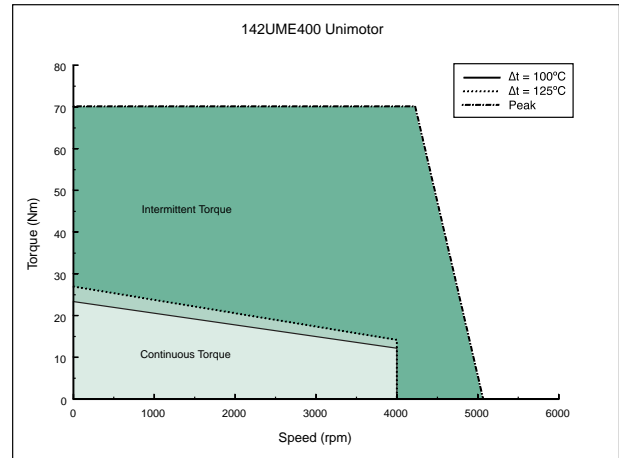

142UMC400 Unimotor

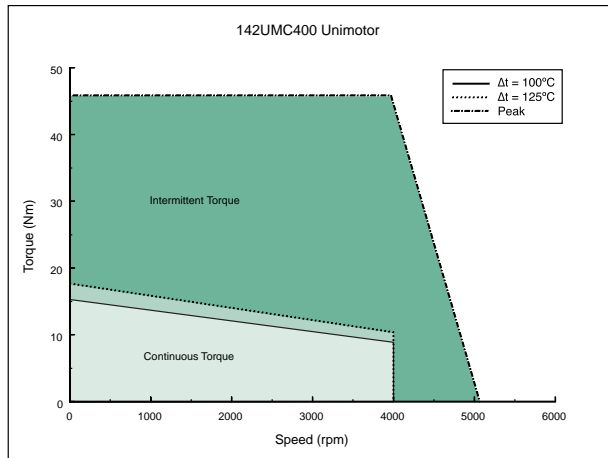

All graphs are at 40°C ambient and 400Vac drive supply
How to use torque-speed graphs see pages 2,3 & 4.

75/6000 RPM

75UMA600 Unimotor

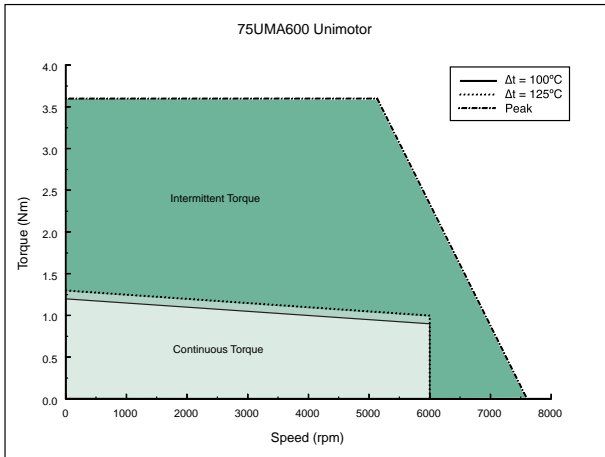

75UMD600 Unimotor

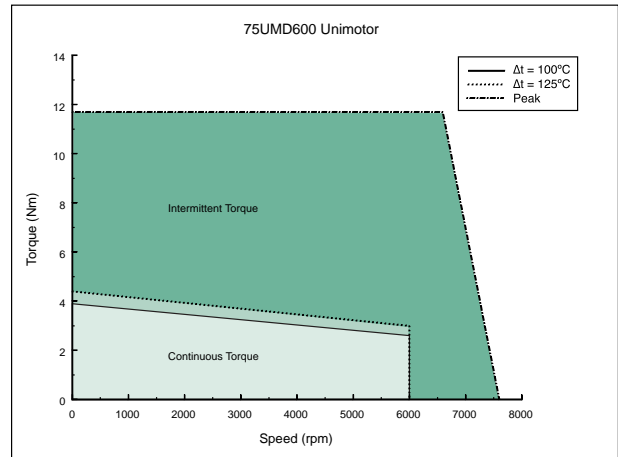

75UMB600 Unimotor

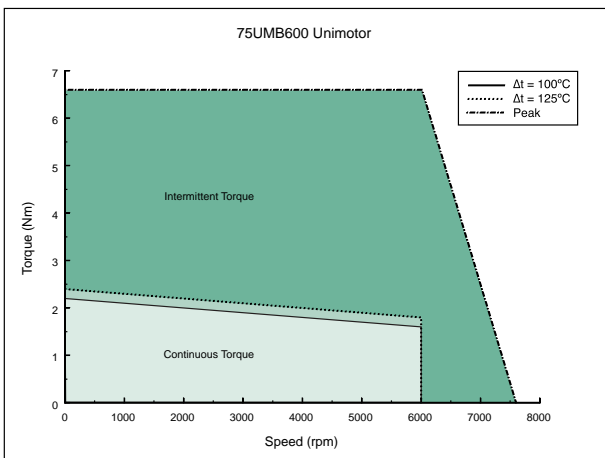

75UMC600 Unimotor

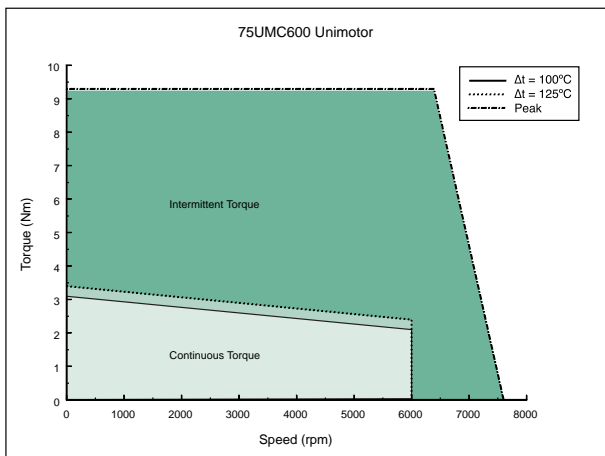

All graphs are at 40°C ambient and 400Vac drive supply
How to use torque-speed graphs see pages 2,3 & 4.

95/6000 RPM

95UMA600 Unimotor

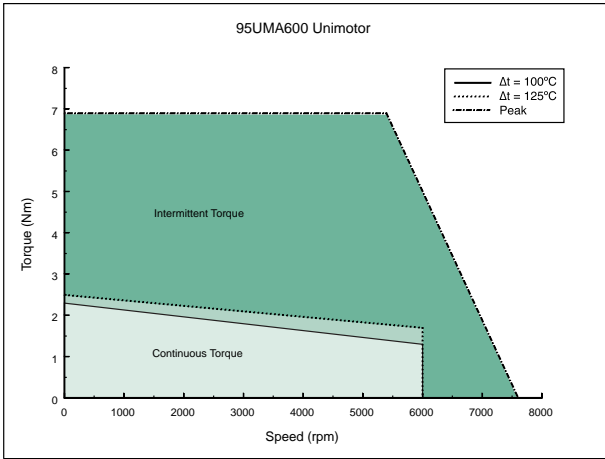

95UMD600 Unimotor

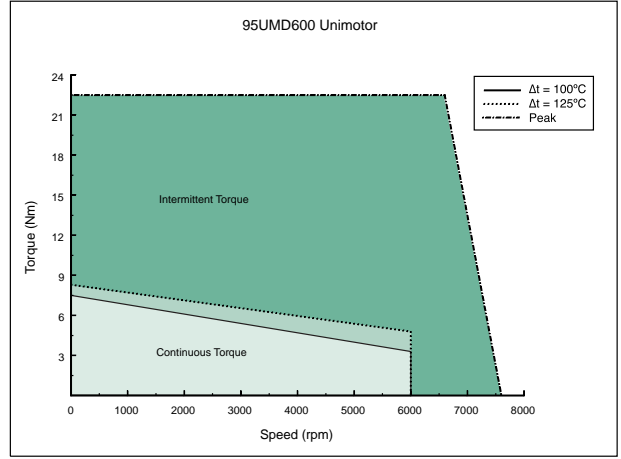

95UMB600 Unimotor

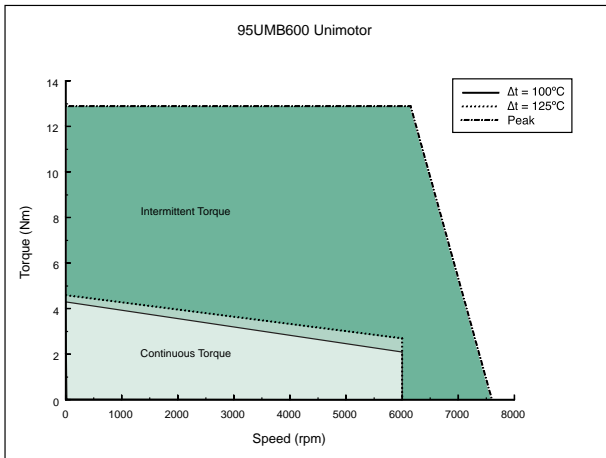

95UME600 Unimotor

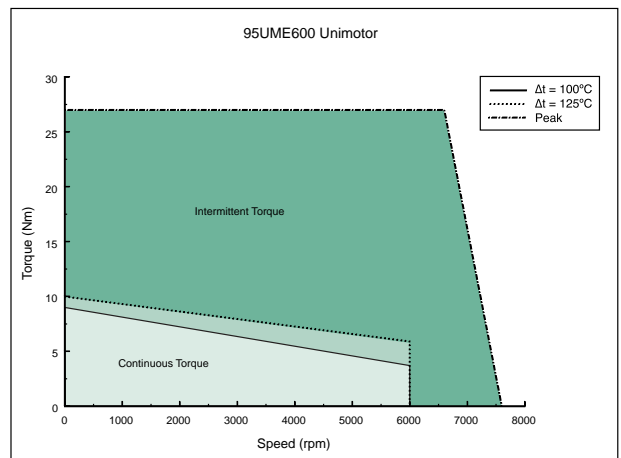

95UMC600 Unimotor

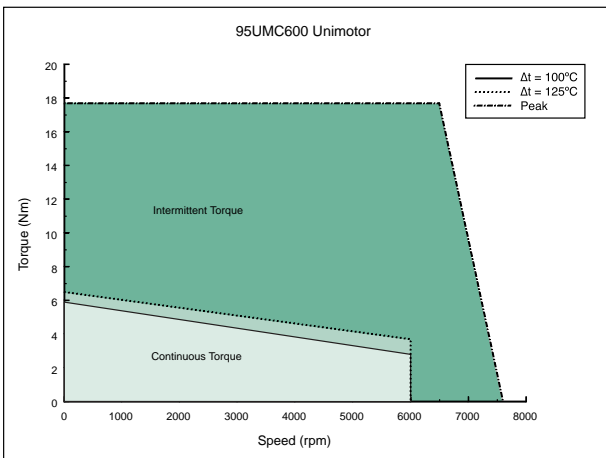

All graphs are at 40°C ambient and 400Vac drive supply
How to use torque-speed graphs see pages 2,3 & 4.

115/6000 RPM

115UMA600 Unimotor

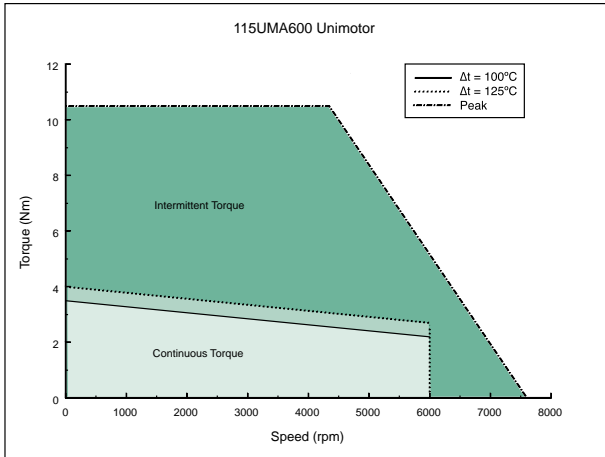

115UMB600 Unimotor

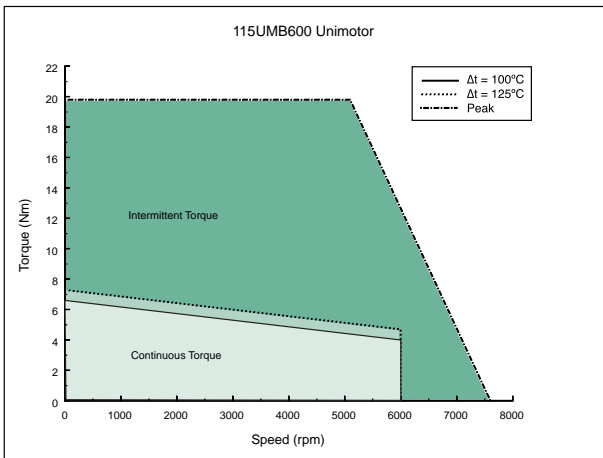

115UMC600 Unimotor

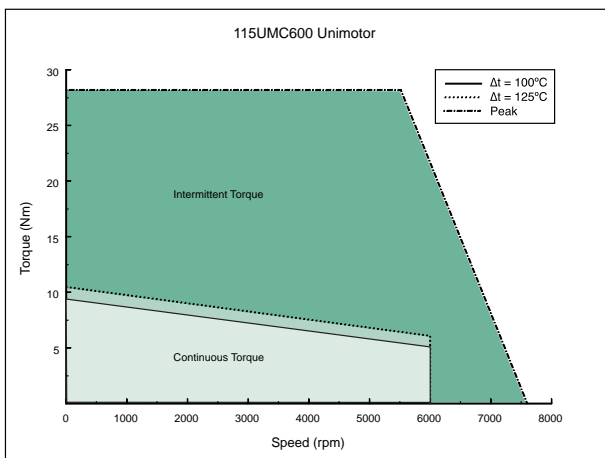

All graphs are at 40°C ambient and 400Vac drive supply
How to use torque-speed graphs see pages 2,3 & 4.

142/6000 RPM

142UMA600 Unimotor

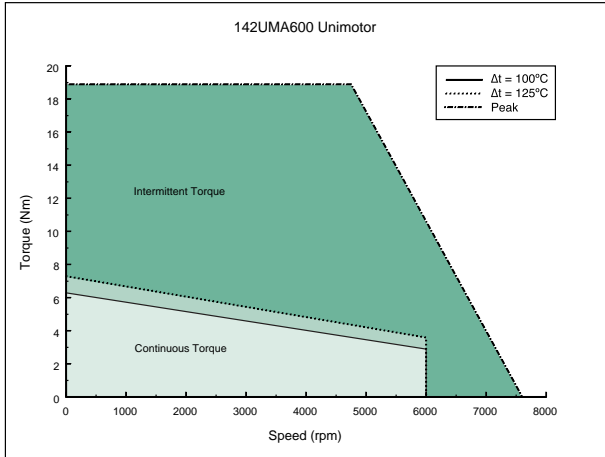

142UMB600 Unimotor

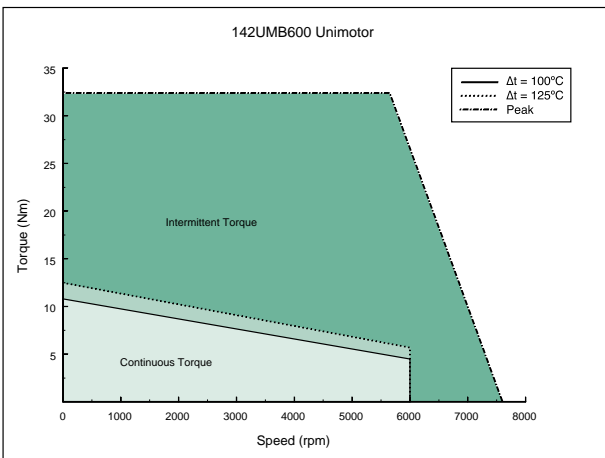

All graphs are at 40°C ambient and 400Vac drive supply
 How to use torque-speed graphs see pages 2,3 & 4.

5

Outline Drawings - Frame Sizes 75 - 142

Note: Overall dimensions shown are maximum values

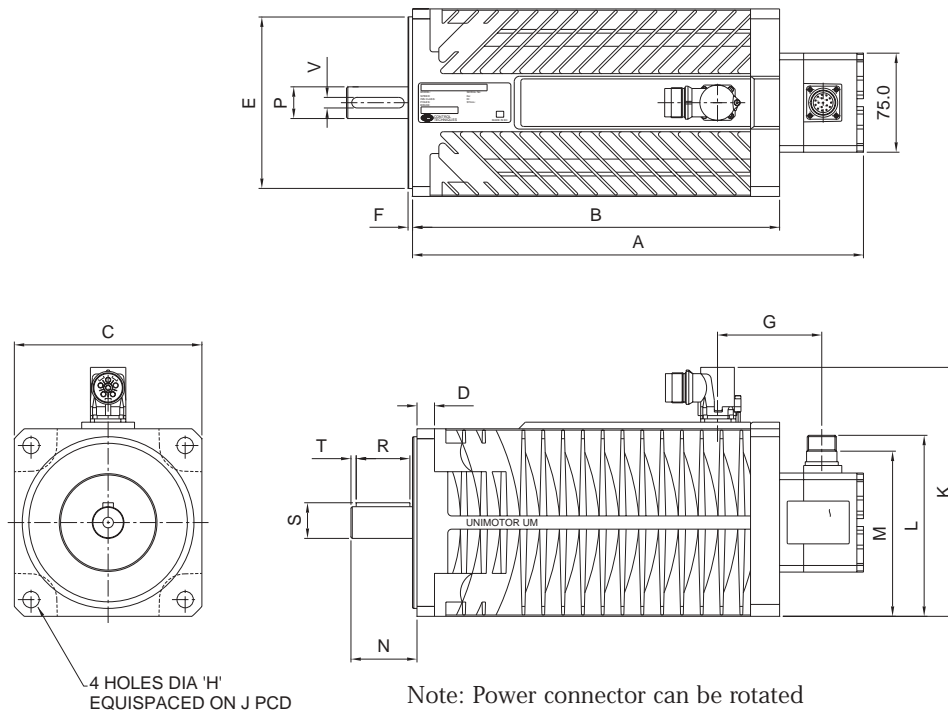

Dimensions - Frame Sizes 75 - 142

Note: Overall dimensions shown are maximum values

FRAME SIZE	75					95					115					142				
	A	B	C	D	E	A	B	C	D	E	A	B	C	D	E	A	B	C	D	E
A Length Overall (Unbraked)	211	241	271	301	342	222	252	282	312	342	242	272	302	332	362	225	255	285	315	345
A Length Overall (Braked)	241	271	301	331	372	252	282	312	342	372	272	302	332	362	392	285	315	345	375	405
B Body Length (Unbraked)	146	176	206	236	277	157	187	217	247	277	177	207	237	267	297	160	190	220	250	280
B Body Length (Braked)	176	206	236	266	307	187	217	247	277	307	207	237	267	297	327	220	250	280	310	340
C Flange Square		75.0					95.0					115.0					142.0			
D Flange Thickness		7.0					9.0					11.0					12.3			
E Register Diameter		60.0 (J6)					80.0 (J6)					95.0 (J6)					130.0 (J6)			
F Register Length		2.4					2.9					2.9					3.4			
G Power to Connect C/L		61.0					62.5					66.0					80.0			
H Fixing Holes Diameter		5.8 (H14)					7.0 (H14)					10.0 (H14)					12.0 (H14)			
J Fixing Hole p.c.d.		75.0					100.0					115.0					165.0			
K Overall Height		126.0					146.0					166.0					193.0			
L Signal Connector Height (UM)		107.0					117.0					127.0					140.0			
M Signal Connector Height (SL)		88.0					98.0					108.0					121.0			
N Shaft Length (front)	23.0	30.0	30.0	30.0	30.0	30.0	40.0	40.0	40.0	40.0	40.0	40.0	50.0	50.0	50.0	50.0	50.0	50.0	50.0	50.0
P Shaft Diameter (J6)	11.0	14.0	14.0	14.0	14.0	14.0	19.0	19.0	19.0	19.0	19.0	19.0	24.0	24.0	24.0	24.0	24.0	24.0	24.0	24.0

Shaft Key Dimensions

(option A)	75					95					115					142				
R Key Length	14.0	22.0	22.0	22.0	22.0	22.0	32.0	32.0	32.0	32.0	32.0	32.0	40.0	40.0	40.0	40.0	40.0	40.0	40.0	40.0
S Key Height	12.4	15.9	15.9	15.9	15.9	15.9	21.4	21.4	21.4	21.4	21.4	21.4	26.9	26.9	26.9	26.9	26.9	26.9	26.9	26.9
T Key to Shaft End	3.5	3.0	3.0	3.0	3.0	3.0	3.0	3.0	3.0	3.0	3.0	3.0	4.0	4.0	4.0	4.0	4.0	4.0	4.0	4.0
V Key Width	4.0	5.0	5.0	5.0	5.0	5.0	6.0	6.0	6.0	6.0	6.0	6.0	8.0	8.0	8.0	8.0	8.0	8.0	8.0	8.0

Typical Weight (Kg)

Low Inertia	3.5	4.3	5.1	5.8	4.7	6.1	7.3	8.8	10.2	7.3	8.9	10.6	12.5	14.2	9.4	12.1	14.7	17.6	20.3
High Inertia	3.9	4.8	5.4	6.3	5.3	6.7	7.9	9.4	10.8	8.5	10.1	11.8	13.7	15.4	11.2	13.9	16.5	19.4	22.1
Low Inertia (braked)	3.7	4.6	5.6	6.1	5.6	7.0	8.2	9.7	11.1	8.2	9.8	11.5	13.4	15.1	11.7	14.4	17.0	19.9	22.6
High Inertia (braked)	4.2	5.1	5.9	6.6	6.2	7.6	8.8	10.3	11.7	9.4	11.0	12.7	14.6	16.3	13.5	16.2	18.8	21.7	24.4

Outline Drawing - Frame Size 190

Note: Overall dimensions shown are maximum values

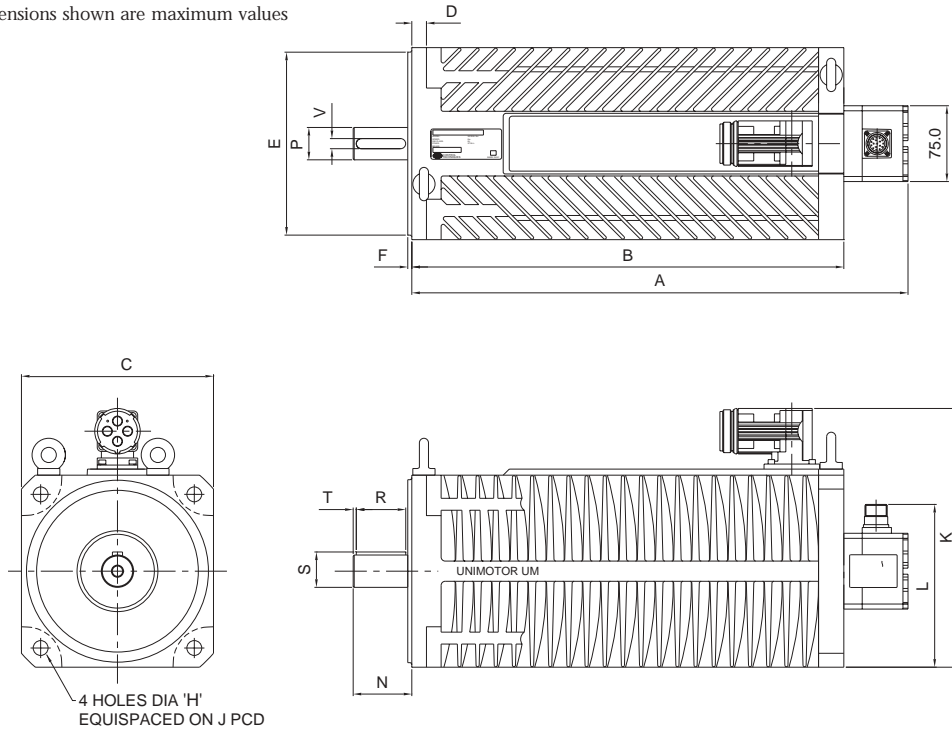

Note: Power connector can be rotated

Dimensions - Frame Size 190

FRAME SIZE		190			
Dimension / Length suffix		A	B	C	D
A	Length Overall (Unbraked)	273	327	381	435
A	Length Overall (Braked)	327	381	435	489
B	Body Length (Unbraked)	210	264	318	372
B	Body Length (Braked)	264	318	372	425
C	Flange Square	190.0			
D	Flange Thickness	14.5			
E	Register Diameter	180.0 (J6)			
F	Register Length	4.0			
H	Fixing Holes Diameter	14.5 (H14)			
J	Fixing Hole p.c.d.	215.0			
K	Overall Height	260.0			
L	Signal Connector Height	161.1			
N	Shaft Length (front)	58.0			
P	Shaft Diameter (front)	32.0(K6)			
Shaft Output Key Dimensions (option A)					
R	Shaft Key Length	49.0			
S	Shaft Key Height	35.0			
T	Shaft Key to Shaft End	3.1			
V	Shaft Key Width	10.0			
Typical Weight (Kg)					
	Low Inertia	23.2	32.0	40.8	49.5
	High Inertia	25.2	34.0	42.8	51.5
	Low Inertia (braked)	25.5	34.3	43.3	52.0
	High Inertia (braked)	27.6	36.3	45.3	54.0

Outline Drawings - Frame Sizes 75 - 142 Hybrid Box

Note: Overall dimensions shown are maximum values

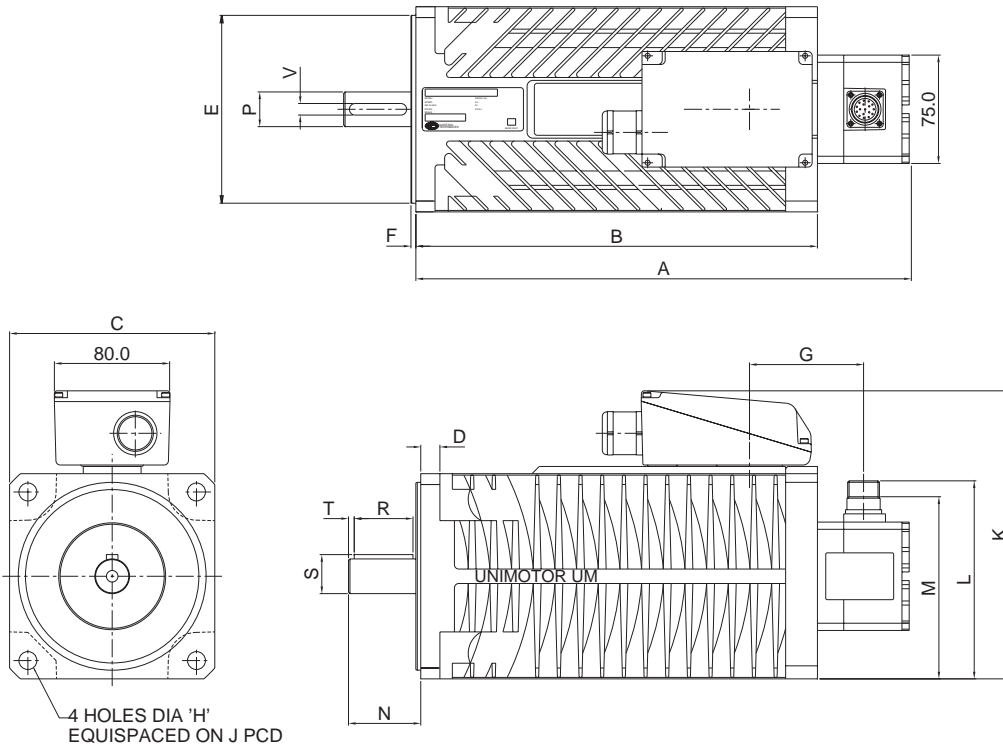

Outline Drawings - Frame Sizes 190 Hybrid Box

Note: Overall dimensions shown are maximum values

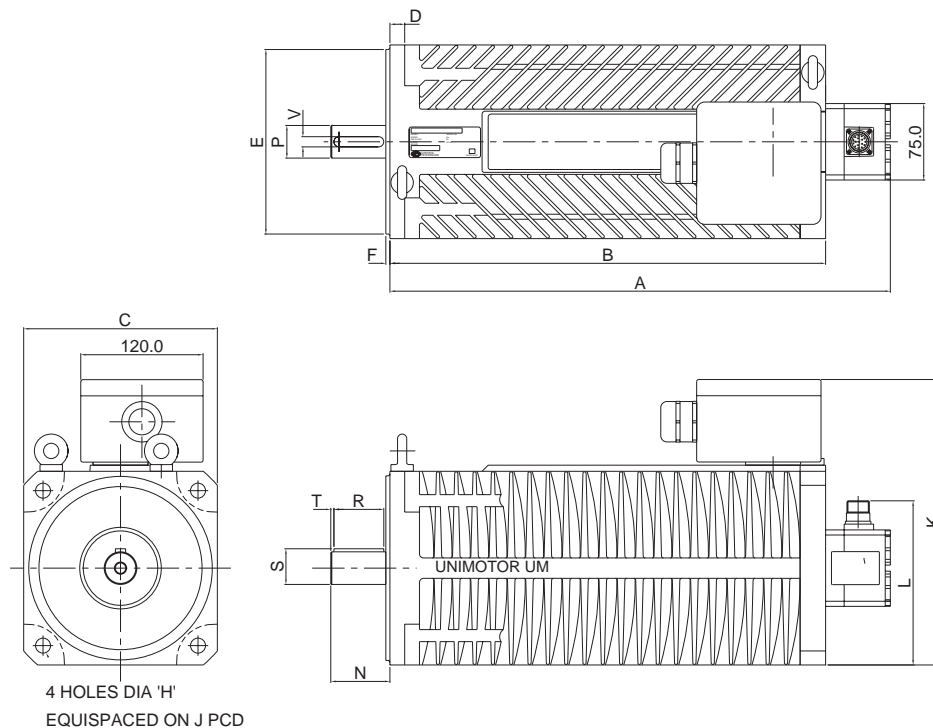

All Dimensions as per page 6-1 with the exception of Dim 'K'

FRAME SIZE	75	95	115	142	190
Dim K	136.0	155.0	175.0	202.0	279.0

Introduction - Feedback Devices

Feedback is the essence of a servo system.

High quality servo performance depends upon the rigidity of the mechanics of the servo system to permit high servo gains and bandwidth without resonance and instability, and upon the resolution and accuracy of the feedback device.

The Unimotor offers selection of feedback types suitable for use with the Unidrive or the M'Ax and MultiAx drives.

The Unidrive has an incremental encoder interface as standard, but with a suitable optional Small Options Module can interface to resolver or sincos (single or multi-turn) types. The M'Ax and MultiAx drives operate with the SL motors with a special sincos-based 'CT-Coder' and built-in SLM electronics.

Feedback type should be chosen to suit the particular application, and the table1 summarises the considerations.

Feedback type	Motor types	Motor Δt °C	Feedback Resolution	Positional Accuracy	Absolute / Non- Volatile?	Multi-turn available?	Comments
Resolver	UM or DM	125	1.3 arc min 16384/ rev	40 min spread 16384/ rev	Yes	No	Use for DigitAx Drive and with Unidrive / Unidrive SP option module for high temp / harsh environment
Incremental optical encoder 4096 ppr in quadrature	UM to 3000rpm	100	1.3 arc min 16384/ rev	+ /-60 sec	No	No	Suits most applications. Low speed control down to 1rpm 300kHz b/w
Incremental optical encoder 2048 ppr in quadrature	UM > 3000rpm	100	2.6 arc min 8192 / rev	+ /-60 sec	No	No	Suits most applications. Low speed control down to 1rpm 300kHz b/w
Sincos optical encoder 1024 cycles/rev	UM	100	0.3 arc sec 2.097x10 ⁶ / rev 1x10 ⁵ / rev best in practice	+ /-52 sec	Yes	Yes	Use for high resolution with Unidrive SP. Unidrive + UD52 Analogue signal is susceptible to noise distortion. Low speed control below 1rpm Better stability when load / motor inertia match is poor. Multi-turn counts 0 to 4096 max
SLM optical 'CT-Coder' 1024 cycles/rev	SL	100	0.16 arc sec 8 x 10 ⁶ /rev	+ /-52sec	Yes Limited position at start up Not multi-turn	No	Use for highest resolution with M'Ax or MultiAx drives. Interpolation at motor and digital link to drive using SLM technology. Better stability when load / motor inertia match is poor.

Table1 – Feedback selection

7

Feedback Types

Resolver

A passive wound component device consisting of stator and rotor elements excited from an external source provided by the UD53 module, (Typically 6Vac, 6kHz).

Two outputs from the stator are 6kHz signals, such that the amplitude of each corresponds to the sine and cosine angle of the motor shaft.

This is a robust absolute device of medium accuracy, capable of withstanding high temperature. Motors fitted with these are rated to higher torque value than for the other feedback devices.

Incremental Encoder

This high accuracy device has good resolution and is a standard choice for most drives.

Position is determined by counting steps or pulses. Two sequences of pulses in quadrature are used so that direction sensing may be determined and 4 x (pulses per rev) may be used for resolution.

Commutation tracks are required to determine a coarse absolute position during motor start to synchronise the drive waveform to the rotor shaft position. The first commutation transition defines the motor commutation position.

A marker pulse occurring once per rev is used to zero the position count.

Position information is volatile – i.e. absolute position is lost when the drive or motor are powered down.

Sincos Single Turn

An absolute encoder system with high resolution, that employs a combination of absolute, sine and cosine and incremental techniques.

Sincos Multi-Turn

Optional for the Sincos encoder, the encoder has additional ability to count complete turns of the motor shaft (non-volatile). This is very useful feature for many types of machine where a “start-up set reference sequence” is undesirable.

Note: *Volatile multi- turn counting is available from most drives for all feedback types.*

CT-Coder & SLM

A high-resolution encoder combined with the SLM electronics within the SL motor for the M'Ax and MultiAx drives gives highest resolution and system performance.

Terminology

Absolute / Non-volatile

This means available position information is not lost when drive power removed, even if the shaft position is rotated with the power off.

Commutation

As with commutating brushed dc motors, all brushless ac permanent magnet motors require commutation information to enable the drive to synchronise with the rotor of the motor.

To ensure optimum torque at all rotor positions both when stationary, and at speed, the drive is required to maintain motor current in phase with the peak of the motor's sinusoidal waveform. The drive must therefore know the position of the rotor with respect to the stator at all times.

Ideally, all feedback devices are aligned with the motor stator during assembly. For those feedback devices that are not aligned, the Unidrive has an Encoder Phasing Test (#3.25) that automatically creates a Phase Position (Phase Offset) value (#3.28).

Commutation Phase Offset

Most drives, including the Unidrive, provide for a “Phase Offset” adjustment and a means of setting this to match a motor with a different commutation setting.

All UM motor feedback devices are set to match the Unidrive definition of zero offset*¹, and similarly DM motor resolvers are set to match the DigitAx drive, so that the drives may operate with zero phase offset adjustment, thus allowing interchange of motors between drives without further adjustment.

Note that not all drives have the same zero offset definition.

All SL motors have built-in motor map definitions including commutation information and are fully “plug & play” with the M'Ax and MultiAx drives.

*¹ Earlier motors with incremental encoders require a specific non-zero phase offset value to be set in Unidrive

Encoders & Encoder Housing - Mechanical Construction

The encoder shaft is directly coupled to the motor shaft. The encoder body is mounted on a flexible, but torsionally rigid, mount. This, together with a specially developed high temperature plastic shield provides a thermal barrier to the motor.

An aluminium housing covers the end of the encoder and permits heat generated by the encoder to dissipate to the air. Viton seals are used between each mechanical interface and the whole assembly is rated to IP 65S.

Incremental Encoder

Three basic variants of the incremental encoders are fitted to match the motor specification and commutation: 4096 ppr (pulses per revolution)- 6 pole; 2048 ppr - 6 pole; and 4096 ppr - 8 pole.

The incremental encoder is the only feedback type that can be used directly with the Unidrive without the use of a small options module.

For all UM with motors with serial numbers ≥ 308340 (August 2001), commutation position is set to match the Unidrive definition of zero offset with sufficient accuracy to permit operation with any Unidrive with commutation offset parameter #3.28 set to zero.

For motors with serial numbers < 308340 , enter number on motor offset label into para. #3.28

Features

- High resolution to 16384 counts with x4 logic (i.e. $4096 \times 4 = 16384$) for excellent speed and position control
- EIA422 digital differential line drivers suitable for cable lengths to 100m
- Digital - for reduced noise susceptibility
- No phase correction required for long cables (resolvers may require phase angle correction depending on cable lengths and motor speeds)
- Phase and quadrature tracks (4096 or 2048 ppr)
- Marker pulse
- Commutation tracks to match motor
- Encoder remains operative at 120°C (100°C maximum for full performance)
- Directly compatible with Control Techniques' Unidrive

Incremental Tracks

At constant rotational speed, viewed facing the front of the motor and in clockwise rotation.

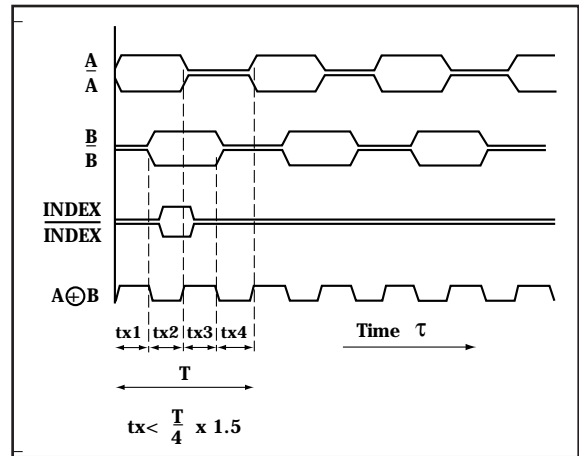

Incremental Encoder Specification

Outputs	Two true and complement square wave signals in quadrature True and complement index reference pulse Three true and complement commutation signals
Output interface	To EIA422 specification (see encoder connections)
Pulses / rev	4096 ppr for 2,000 rpm and 3,000 rpm motors (16,384 counts per turn) 2048 ppr for motors above 3,000 rpm (8,192 counts per turn)
Max. output frequency	300 kHz
Max. encoder shaft speed	9,000 rpm (mechanical limit)
Commutation signals	3 tracks each 3 ppr on 6 pole motors (frame size 75mm to 142mm) or 3 tracks each 4 ppr on 8 pole motors (frame size 190mm)
Operating voltage range	5.0 volts \pm 10%
Operating current	50 mA - 150 mA, maximum no-load; 300 mA max. at 300 kHz with RS 422 loads

Commutation Outputs

The diagram below shows commutation outputs for 6 pole commutation (3 pole pairs). The 3 phase motor sinusoidal power from the drive runs synchronously with motor speed at $N/2$ cycles per revolution;

where, N = number of poles.

Thus, a 6 pole motor has 3 electrical power cycles per revolution. For 8 pole motors, the encoder commutation tracks will give 4 pulses per revolution. Note that the direction sense is reversed if the polarity of S2 track is inverted.

Commutation outputs showing relationship with index

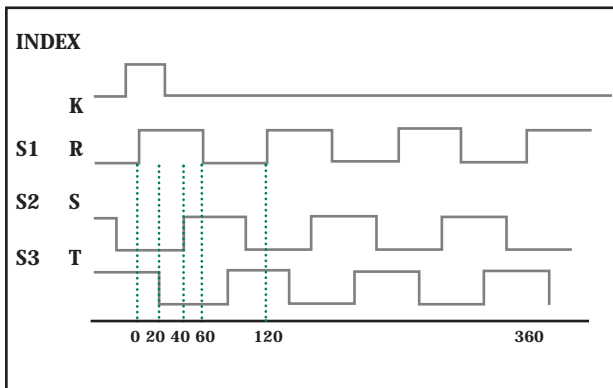

N.B. Inverse signals are not shown

EIA422 Outputs

Applicable to each of the six outputs.

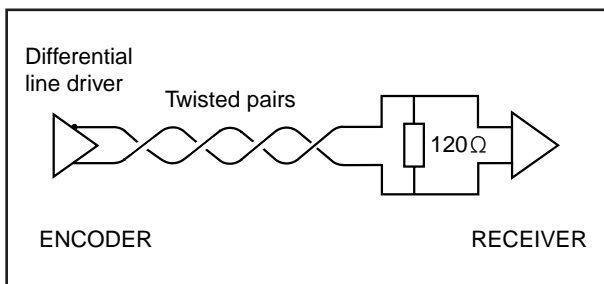

EIA422 Interface

Incremental Encoder Connections

The figure below shows the pin allocation of the 17 pin Unimotor signal connector (incremental feedback).

The signal cable must comprise of 8 twisted pair in an overall screen, with ideally the thermistor pair also screened. Each twisted pair is allocated to a signal and its complement (inverse). The + 5 Volts and 0 Volt pair should be 1.0 mm² cross section conductor to avoid

voltage drop on long cables. The overall screen must be braided (not foil), for flexibility. It is important to have correct screen connection at both motor and drive ends.

CT Dynamics recommend the use of ready-made and tested cables for reliable and fast installation. (See Cables section.)

SIGNAL CONNECTOR INCREMENTAL ENCODERS

(17 PIN)

Connector size 1 for all motors

Function	Pin
Thermistor, PTC	1
Thermistor, PTC return	2
Screen	3
S1	4
S1 inverse	5
S2	6
S2 inverse	7
S3	8
S3 inverse	9
CH A	10
Index	11
Index inverse	12
CH A inverse	13
CH B	14
CH B inverse	15
+ 5V dc	16
0V	17

Unidrive speed restriction

Unidrive has an encoder signal input bandwidth limit of 250 kHz and will inhibit speed demands greater than 3660rpm for a 4096 ppr encoder.

Unidrive SP has a bandwidth limit of 410 kHz so that an encoder bandwidth limit of 300 kHz will prevail as the limiting factor.

The Unimotor label is now marked with maximum speed that will reflect the speed maximum limit of the feedback device. A 4096 ppr incremental encoder with a 300 kHz bandwidth will have a speed limit of 4830rpm. Drive parameter #1.06 must be set to a value equal or less than the maximum speed corresponding to this limit, see also **n_{NMAX}**, sections 3- and 4-2

Synchronising two encoder systems

A Unidrive UD51 Small Options Module enables the host system to achieve synchronisation with an external encoder system. For further details refer to Control Techniques Technical Support.

Sincos SRS50 & SRM50 Encoders

Features

- Absolute encoder
- 1024 sin & cosine cycles per turn
- High resolution to 2 million counts per turn
- Very high accuracy
- 8 wire connection
- Choice of single or multi-turn
- Built-in non-linearity corrections
- 8V operation
(set UD52 parameter # 16.15 = 1 for 8V)

Important Notes:

Previously, UM motors have been fitted with SCS60 & SCM60 encoders. These have a similar specification, but were 512 cycles / turn.

Unidrive must have software version 03.02.11 or higher to function correctly with the SRS 50 or SRM 50 encoder.

Unidrive SP does not require an options module. The following description applies to UD52 as required for Unidrive.

Functional Description

A true absolute encoder requires encoding of the disc data in such a way that position can be read to the full accuracy in any condition – notably at switch on - and at speed. In this case, a high frequency data line would be required to transmit high-resolution information at high shaft speeds. This can be expensive and the sincos system is an excellent compromise.

The Sincos system can be considered as a mixture of an incremental encoder and an absolute encoder.

It is configured to give an absolute position via EIA485 digital link, plus sine and cosine analogue 1024 cycles per rev waveforms via twisted-wire pairs.

The absolute encoder inside the SRS/SRM50 determines 0 – 32767 counts of position. Every eight steps of this represent one quadrant of the 1024 sine wave. (i.e. $1024 \times 4 \times 8 = 32768$).

At start-up, when the shaft is stationary, absolute position is transmitted as serial digital data to the UD52 from which the absolute position can be determined by use of the digital count and by some interpolation of the 1024 sine and cosine waveforms to give a finer resolution (Fig 1).

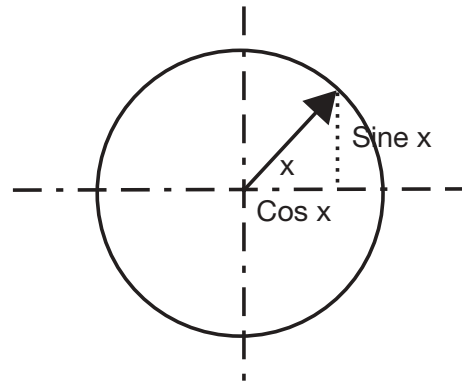

Fig 1

Fig 1

The UD52 pre-loads a quadrant counter with a quadrant count derived from the absolute count and, once loaded, there is no further requirement to digitally read the absolute position from the encoder until a power-down situation occurs.

As the shaft turns, the counter increments or decrements according to quadrant information easily derived from the sine and cosine analogue waveforms. Additional resolution is obtained from the tangent of x of a single cycle of the 1024 cycles per rev waveforms (Fig 1)

The UD52 is configured to create:

- parameter #16.03 – revolution count (0 – 32767 counts)¹
- parameter #16.04 – encoder position, coarse (0 – 16383 counts)
- parameter #16.05 – encoder position, fine (0 – 255 counting in steps of 2)

This gives a total resolution of $16384 \times 128 = 2097152$ counts per turn.

¹For SRS50, this may be configured to be $(2^n - 1)$ where parameter #16.13 = n (0 – 15) and turn count will be relative to start, i.e. volatile.

N.B. for absolute multi-turn SRM50 encoder, set parameter #16.13 = 12 (for 0 – 4095 counts)

SinCos Multi-Turn

The SRM50 encoder has additional mechanical gearing and sensors to permit absolute, non-volatile counting of turns to a total of 0 - 4095 turns.

N.B. at 4095 next turn will be 0; conversely at 0 a reverse turn will indicate 4095).

Turns are counted even when power is switched off.

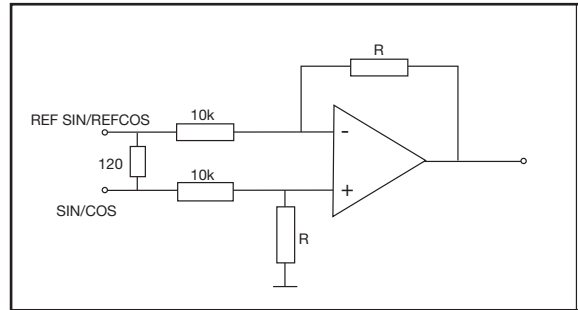
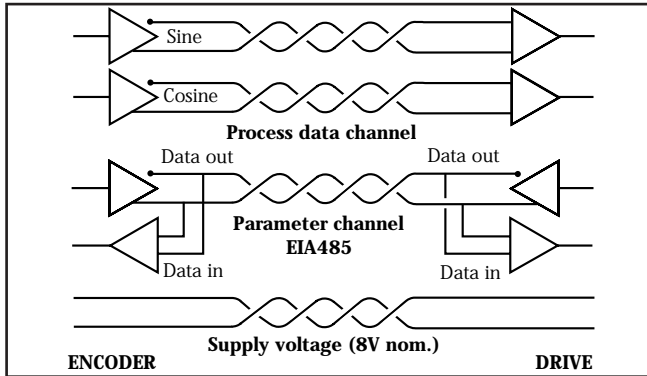

Recommended Receiver Circuit for Sine and Cosine Signals

Commutation

The encoder position relative to the motor shaft has been set for all UM motors with serial numbers > s/n 348340

SRS50 & SRM50 Specification

Sine & cosine analogue outputs	1024 per rev
Rotor Inertia	10 gcm ²
Max angular acceleration	0.2 x 10 ⁶ rad/s ²
Operating torque	0.2 Nm
Code progression with clockwise rotation viewed on end of motor	Ascending
SRM50 multi-turn counts	4096
Positional accuracy	+ /-52 seconds of arc
Max frequency for sine wave channels	200 kHz
Maximum working speed for position calculation	6000 rpm
Bearing service life	3.6 x 10 ⁹ revs
Working temperature range	-20.+ 115° C
Working voltage	7 -12 V
Recommended voltage	8V
Max no load operating current	80mA
Data channel	EIA485

SIGNAL CONNECTOR FOR SINCOS

(12 pin)

Function	Pin
Ref cosine	1
+ EIA485	2
-EIA485	3
Cosine	4
Sine	5
Ref sine	6
Motor thermistor	7
Motor thermistor return	8
Screen	9
0V	10
Not Connected	11
8v dc	12

CT-Coder and SLM

The feedback cover of SL motors conceals the “CT-Coder” and SLM electronics. The CT-Coder is a 1024 cycles per rev sin-cos encoder adapted to match the electronics. The high-density surface mount SLM electronics packs a microprocessor; firmware; A-D converter; and an ASIC. Together, these enable a number of functions to be achieved including the calculation of absolute position to the equivalent of 8,388,608 ppr resolution and protocol control for the bi-directional EIA485 data link.

Additional functions include temperature reference from a linear thermistor; read/write interface to the E²PROM of the CT-Coder and a + 5V dc regulator.

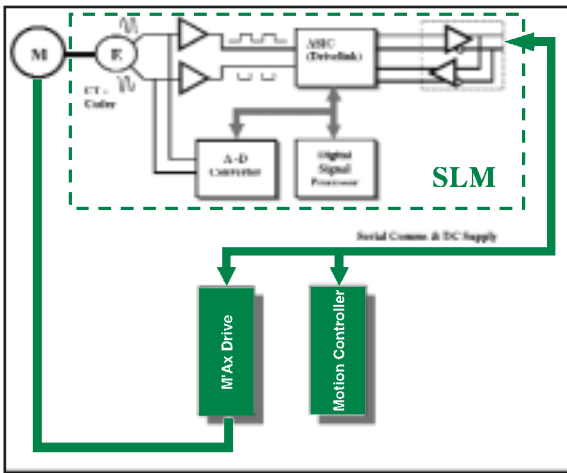

FIG 1 SLM system

SLM Features

- Motor mounted speed loop system
- High-precision SIN-COS encoder (CT-Coder)
- Resolution to less than one eight millionth of a rev, with 50ns synchronisation
 - Enables stable higher loop gains for ultra low ripple torque down to fractions of rpm
- Digital signal processor
- High-speed, two-wire EIA485 serial communications interface to M'Ax or MultiAx drives - no performance degradation in noisy environments upto 4kV
- Only 4 wire connection + screen - lower cost simplified wiring
- Cable connection up to 50m
- Full motor data contained within motor for instant plug and play interchangeability
- Built-in error correction
- Motors to $\Delta T = 100^{\circ}\text{C}$ at 40°C ambient
- UL approved thermal protection software

Speed Loop Feedback System – specification

Enclosure IP65

SL system:

Shaft resolution 4194304 (2²²) pulses per rev
 EIA485 data link 2.5 Mb/s, 50ns synchronisation
 Information transmitted over the serial communications link from motion controller

- Position and speed demand a motion controller
- Position feedback to the controller
- Current/torque demand to the Drive
- Parameter values (see E²-PROM)

Cycle time from drive 125 μ s
 Power requirements 24V dc +/- 20%

CT-Coder:

Sine & cosine analogue outputs 1024 cycles per rev or 1 cycle per rev, selectable
 Max frequency of sine & cosine 100 kHz
 Voltage supply + 5V +/- 10% from SLM regulator
 Bearing life 3.6 x 10⁹ revolutions
 Working temperature range 0 - 100 $^{\circ}\text{C}$
 Operating temperature -20 - 125 $^{\circ}\text{C}$
 Storage temperature -40 - 125 $^{\circ}\text{C}$

FIG 2 SLM PIN CONNECTION

Function	Pin
COM /	1
0V	2
+ 24V	3
Screen	4
COM	5

E²PROM

There are 3 'object' files stored in the E²PROM:

- Encoder (for CT-Coder offset correction)
- Motor (Motor type identification and serial number)
- Eze object (Motor performance parameters)

The Encoder object is protected and is preset by the encoder manufacturer.

Motor and Eze objects are created during production set-up and are read-only. (Update capability available to authorised personnel only.)

The motor object may optionally be used by the customer interface for read only information.

The Eze object contains all the actual motor data needed to enable M'Ax or MultiAx drives to automatically set optimum parameters for an instant system set-up.

Motor Object - specification

Motor object parameters can be accessed via the data bus.
e.g. Motor object type 1 is M'Ax COM parameter #23

M'Ax Drive MOTOR OBJECT PARAMETERS #23 - #28

- #23 motor type 1 (see next page)
- #24 motor type 2 (see next page)
- #25 manufacturer ; CTD = 1
 bit 0= decimal 1(0000000000000001)
- #26 serial number part 1 most significant three
 decimal digits
- #27 serial number part 2 next significant three
 decimal digits
- #28 serial number part 3 least significant three
 decimal digits

e.g. serial 48079

	decimal
#26	000
#27	048
#28	079



SL Motor and SL Module

Motor type1 definition
Frame size

n	15	14	13	12	11
2 ⁿ	32768	16384	8192	4096	2048
75	0	0	1	0	0
95	0	0	1	1	0
115	0	1	0	0	0
142	0	1	0	1	0
190	0	1	1	0	0

SL motor type

n	10	9
2 ⁿ	1024	512
SL	0	1

Motor length

n	8	7	6	5
2 ⁿ	256	128	64	32
A	0	0	0	0
B	0	0	0	1
C	0	0	1	0
D	0	0	1	1
E	0	1	0	0

Motor Rated Speed

n	4	3	2	1
2n	16	8	4	2
1500	0	0	0	1
2000	0	0	1	0
2500	0	0	1	1
3000	0	1	0	0
3500	0	1	0	1
4000	0	1	1	0
4500	0	1	1	1
5000	1	0	0	0
5500	1	0	0	1
6000	1	0	1	0

Brake

n	0
2 ⁿ	1
brake	1
No brake	0

Motor type2 definition
Connector type

n	15	14	13
2n	32768	16384	8192
C	0	0	0

Shaft key / Special

n	12	11
2 ⁿ	4096	2048
key	0	0
no key	0	1
SPECIAL	1	0

Feedback device

n	10	9	8
2 ⁿ	1024	512	256
P	0	0	1

IEC Flange or Gearbox

	n	7	6	5	4
	2 ⁿ	128	64	32	16
IEC flange, no gearbox	A	0	0	0	1
Gearbox fitted	X	1	1	1	0

SIGNAL CONNECTOR FOR SLM

n	3	2	1	0
2n	8	4	2	1
A (LOW)	0	0	0	1
B (HIGH)	0	0	1	0

Resolver

Consisting of a stator and a rotor, the resolver continuously measures the angular position of the motor rotor. A resolver is typically more robust than an encoder, but gives lower accuracy.

Arranged in the stator are an excitation winding and two windings, mechanically offset by 90°. The rotor winding (2 pole) is housed in the rotor. An excitation signal of approximately 6 kHz is linked without direct contact via the excitation winding into the rotor winding. The excitation signal induces voltages of equal frequency into the stator windings. The amplitudes of the induced voltages are proportional to the cosine and sine respectively of the rotor angle. With the aid of electronic circuits, these signals enable the rotor position to be measured absolutely over one motor revolution (for commutation); the value of the motor speed to be derived by digital or analogue means, and incremental signals for positioning guidance to be created via encoder simulation.

The resolver itself contains no electronic components and can withstand high temperature environments. A resolver is the ideal reliable transmitter for use in harsh environmental conditions. The resolver rotor is mounted directly on the motor shaft, so giving a robust and accurate measurement system for velocity and position signals.

Features

- Absolute position
- No loss of feedback information during fast transient disturbances
- Robust construction
- High temperature motor operation to 165°C
- ± 15 mins of arc accuracy

Typical Resolver Section

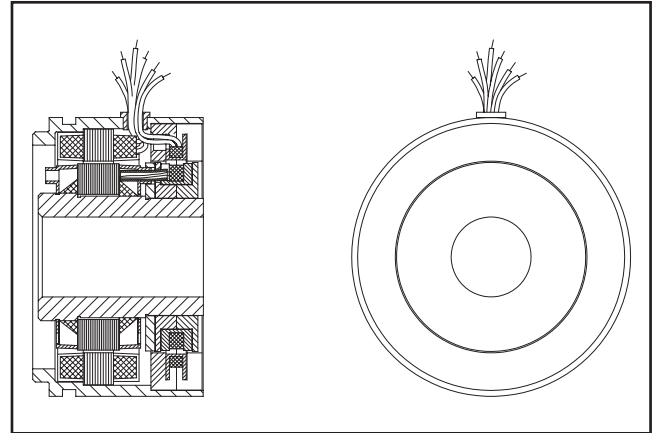

Resolver Circuit

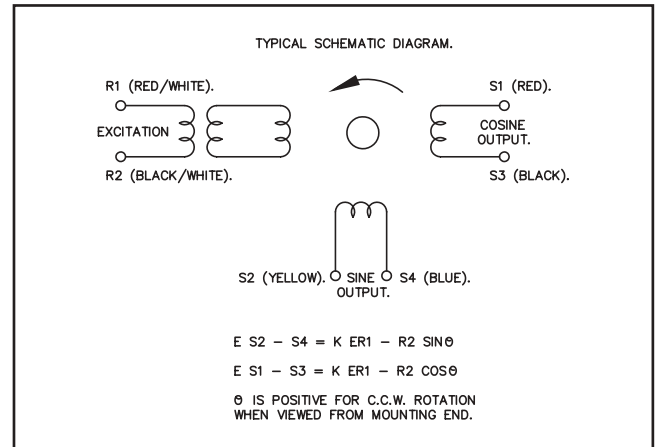

Schematic Diagram

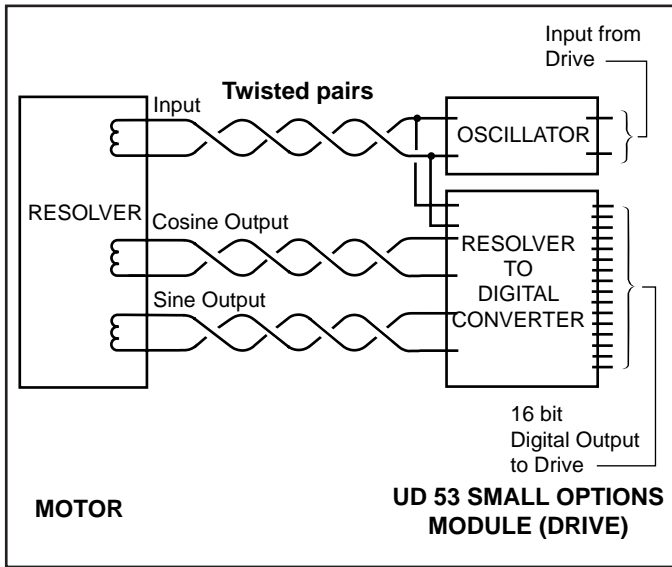

Drive Systems

Use resolver interface when using Unidrive or Unidrive SP. Unimotors fitted with resolvers will also operate with DigitAx drive, but note rotational direction will be reversed. Unimotor type DM is available with compatible and rotational direction.

Commutation

Resolvers are factory set for correct commutation position, and should require no additional adjustment. However, it is necessary to set the drive correctly by running the resolver phase check routine.

SIGNAL CONNECTOR RESOLVER

(12 pin) signal connector size 1 for all motors

Specification

Voltage	6V
Frequency	7.5 kHz
Primary	Rotor
No. of poles	2
Transformation ratio	0.28 ± 10% (0.3 ± 10% for models after mid-2003)
Phase shift	-7° nom
Primary current	40 mA nom
Input power	120 mW max
Electrical error	± 15 mins (standard)
Total null volts	30.0 mV max
Impedances	Z _{ro} 73+ j129 nom Z _{so} 116+ j159 nom Z _{ss} 95+ j162 nom
Temperature range	-55°C to 155°C
Rotor inertia	20 x 10 ⁻⁶ kgm ²

Function	Pin
Excitation (high)	1
Excitation (low)	2
Cosine (high)	3
Cosine (low)	4
Sine (high)	5
Sine (low)	6
Thermistor, ptc	7
Thermistor, ptc return	8
Not used	9
Not used	10
Not used	11
Not used	12

N.B. Definitions applicable to both UM and DM motor types.

7

Fail Safe Parking Brakes

Any Unimotor may optionally be ordered with an internal rear mounted parking brake. The brake works on a fail safe principle: the brake is active when the supply voltage is switched off and the brake is released when the supply voltage is switched on. The table below shows the delay times that occur when the brake is switched on or off. Shunting the brake with an external diode to avoid switching peaks increases the coil's decay time (t_{OUT}) considerably.

If a motor is fitted with a fail safe brake, take care not to expose the motor shaft to excessive torsional shocks or resonances when the brake is engaged or disengaged. Doing so can damage the brake.

SAFETY NOTE: The Fail-Safe Brake is for use as a holding brake with the motor shaft stationary. Do NOT use it as a dynamic brake, except for emergencies such as a mains supply failure.

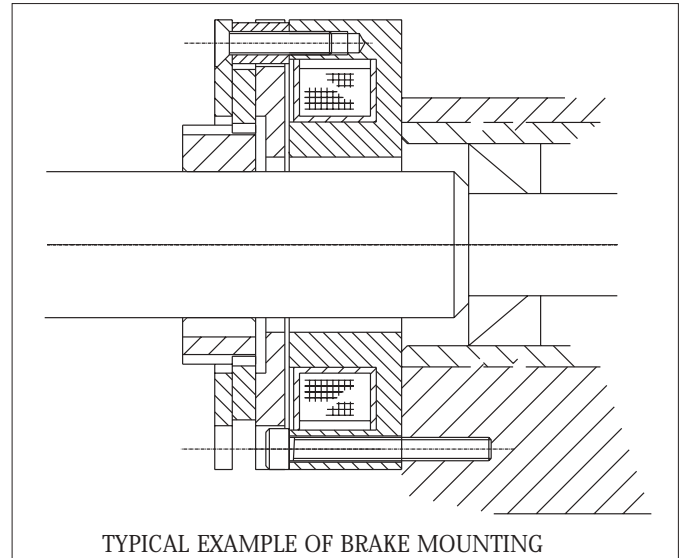

Technical Data

MOTOR FRAME SIZE	VOLTS	POWER	STATIC TORQUE	RELEASE TIME (Coil Energised)	BRAKE ON-TIME (Coil de-energising no diode)	BRAKE ON-TIME (Coil de-energising with diode)	INERTIA	BACKLASH
(mm)	DC	W	(Nm)	(ms nominal)	(ms nominal)	(ms nominal)	(kgcm ²)*2	(degrees)
75	24	6.3	2	22	24	100	0.03	0.75
95	24	16	6*1	30	20	140	0.29	0.75
115	24	16	12	40	10	60	0.49	0.75
142	24	23	20	85	30	200	1.28	0.6
190(A/B)	24	25	40	95	15	85	1.28	0.6
190(C/D)	24	25	60	120	20	150	2.50	0.6

Note that the brake response time is extended when a diode is fitted across the brake coil at the driver (customer) end. This is usually required to protect solid state switches, or to reduce arcing at the relay contacts

*1 Brake rating changes to 12Nm after mid-2003

*2 1kgcm² = 1x10⁻⁴kgm²

Special Brakes

Where volumes have justified it, CTD have designed a number of custom products with customer specific brakes. Please contact CTD if you have a requirement for a special application.

Introduction

Although CTD servomotors can operate smoothly at full torque from 1 rpm (sincos and SL - from small fractions of rpm) to full rated speed, the addition of a gearbox can be a useful torque multiplier and can also provide a better match to high inertia loads.

A Gearbox May Help If:-

- Load is high torque, usually below 1000rpm
- Load is high inertia
- Load has unusually high axial or radial loads
- Small overall size with small motor
- Possible cost reduction with smaller motor & drive package
- Space constraints where right angle option or smaller overall package helps

For example: -

- A 1.2Nm 4000rpm motor fitted with 100:1 ratio gearbox gives a continuous torque around 100Nm, albeit at a reduced speed of 40rpm max.
- A 4,000rpm motor with a 4:1 gearbox in certain circumstances may offer a better performance than a 2,000rpm motor alone working at 1000rpm with large inertial load. The motor torque required for the gearbox is 3 to 4 times less, whilst the reflected load inertia is reduced by 16 (= ratio²), so that a better match of motor/load inertia results and greater stability with higher servo gains are possible.

What's Available:-

CT Dynamics offers a range of gearboxes supplied fitted to any CT motor (55 to 190 frame sizes).

If required, gearboxes can also be supplied separately.

By following a simple selection procedure, a suitable motor-gearbox combination may be selected from specifications provided in this section.

Gearbox specifications appended to this section are quality planetary gearboxes and include low backlash, standard backlash, single-stage, and two-stage with ratios up to 100:1.

Gearboxes with 90 degree angled output shafts can increase the possible ratio permutations up to 200:1.

The gearbox output shaft can optionally be fitted with key.

The motor-gearbox assembly comprises of the gearbox, an integral gearbox adaptor plate, and a standard CT motor.

The motor-gearbox assembly is normally supported from the front face / flange of an in-line gear reducer. For a right angled gearbox, the SPK, mounting support is also to the gearbox flange, but for the WT, mounting support is to the gearbox frame .

Features - Gearboxes

- High quality, low backlash, low noise
- Taper bearings (not on the LP)
- Wide selection
- Planetary gearboxes for high efficiency and low inertia
- High strength
- Long service life
- Ratios to 100:1 (200:1 for SPK)
- Lifetime lubrication to suit any mounting attitude
- Gearbox IP64 protection rating
- To suit all 55 to 190 UM, SL, DM & EZ motors



Ordering a Motor-Gearbox

To order a gearbox, please supply the following information:

Item	Example
1 Motor type number	75SLB600C*PXA * = A for key at gearbox output or B for no key at gearbox output X specifies gearbox fitted
2 Gearbox Style & Size	SP75
3 Ratio	50
4 Special requests	e.g. reduced backlash (not available for LP)

Example 1 142UMB400CA¹CXA with SP 140 - 20 ratio - with key
= 142UMB400CACXA-SP140-020

Example 2 115UMB300CB¹SXA with SK 100 - 3 ratio - no key
= 115UMB300CBSXA-SK100-003

Example 3 75UMB300CB¹CXA with SPK 075 - 14 ratio - no key
= 75UMB300CBCXA-SPK075-014

Example 4 142UMC200CB¹AXA with LP 155 - 10 ratio - with key
= 142UMC200CBAXA-LP155-010
*Note: LP gearboxes are **always** supplied with a key.*

Example 5 95SLD400CB¹PXA with PG 100 - 7 ratio - with key – reduced backlash
= 95SLD400CSxxx with PG100-007-01 + reduced backlash
Example 5 has a special request, and so is designated as a special motor-gearbox type “xxx”. Where “xxx” are 2 or 3 alphabetical characters

¹ **A** - signifies a keyed gearbox output shaft.

¹ **B** - signifies a plain gearbox output shaft.

X - indicates motor has attached gearbox.

Note: Characters G to S in this position were originally used to indicate gear ratio. X to indicate a gearbox supersedes this.

Gearbox Styles & Types

Gearbox parameters for various manufacturers and gearbox types are included at the end of the gearbox section. From this and the information below, select a gearbox type to suit requirements, including backlash. Reduced backlash is available by special request only where indicated.

Alpha gearbox types: -

• SP

A high precision 1 or 2 stage planetary gearboxes all with low backlash, and front flange mounting.

Single stage ratios: 4 / 5 / 7 / 10

Two stage ratios: 16 / 20 / 28 / 40 / 50 / 70 / 100

Torsional backlash: 1 stage: < 4 - 6 arcmin
2 stage: < 6 - 8 arcmin

Special reduced backlash: 1 stage: < 2 - 4 arcmin
2 stage: < 4 - 6 arcmin

• LP

This robust cost effective 1 or 2 stage planetary gearbox has circular mounting face with spigot and tapped holes (i.e. without flange at mounting surface).

LP Note: - Output shaft always has a key fitted (remove key if not required)

Ratios		
Type	Single	Two Stage
LP 070/090/120	3* / 5 / 7 / 10	15* / 25 / 30* / 50 / 100
LP 050/115	5 / 10	25 / 50 / 100

Torsional backlash: 1 stage: < 12 arcmin
2 stage: < 15 arcmin

Reduced backlash is not available for LP

• SK

These 90-degree bevel gear units are available with ratios of 1, 2, or 3.

This single stage SK can be used on its own where 90-degree transmission is required.

Single stage ratios: 1 / 2 / 3

Torsional backlash: < 4 - 5 arcmin

Reduced backlash is not available for SK

Due to production handling problems, this range is restricted to the smaller motor sizes only. Please ask for details.

• SPK

A single stage SK 90-degree bevel gear unit fitted with a 1 or 2-stage SP gearbox constitutes an SPK gearbox assembly with 2 or 3 stages.

Two stage ratios: 4 / 5 / 7 / 10 / 14 / 20

Three stage ratios: 32 / 40 / 56 / 80 / 100 / 140 / 200

Torsional backlash: 2 stage: < 5 - 7 arcmin standard;
(3 - 5 arcmin) special reduced
3 stage: < 6 - 8 arcmin standard;
(4 - 6 arcmin) special reduced

Due to production handling problems, this range may be restricted to the smaller motor sizes only. Please ask for details.

ZF gearbox types: -

• PG

High precision planetary gearboxes with low-backlash and front flange mounting.

The PG gearbox is compatible to Alpha's SP and has a similar specification.

Single stage ratios: 4 / 5 / 7 / 10

Two stage ratios: TBA

Torsional backlash: 1 stage: < 4 - 6 arcmin standard

Special reduced backlash: < 2 - 3 arcmin

• WT

A high precision, low backlash 90-degree gearbox designed for highly dynamic servos. Highly accurate Gleason hypoid gearing creates a compact single stage reduction that can permit the high transmission ratios of a bevel gear. Gearbox and motor assembly is normally supported from one of the gearbox faces. IP64 rated.

Single stage ratios: 3 / 4 / 5 / 6 / 8 / 10 / 12 / 15

Torsional backlash: 1 stage: < 4 - 6 arcmin

Special reduced backlash: 1 stage: < 2 - 3 arcmin

Due to production handling problems, this range may be restricted to the smaller motor sizes only. Please ask for details.

Gearbox Selection - System Requirements

Tables 1 to 4 are provided for guidance, but for simplicity, certain parameter considerations such as acceleration torque are omitted.

To be thorough, follow the procedure commencing at **Full Selection Method** (See also flow chart, Fig 2), referencing the manufacturer's data contained at the end of this section.

Gearbox drawings and dimensions can be found in the manufacturer's data. The motor adaptor plate is part of the gearbox and the dimensions include this.

The quantity of motor-gearbox combinations is so great that it is not possible to show combined outline drawings. A complete motor-gearbox outline can be determined from the motor dimensions of **Motor Dimensions Section**, and the gearbox dimensions of the manufacturers data at the end of this section.

Quick Selection

• Decide on Gear Ratio

First, select the gear ratio, motor and motor speed that best matches the system for torque and inertia match. De-rate motor by 5% and allow for the gearbox efficiency.

To assist in the system design, use the CTSS sizing software (Free download from controltechniques.co.uk – Drives Portal)

• Choose Gearbox Type

Select style of gearbox based upon nominal torque at output, backlash requirements, mechanical arrangements and costs. Use Tables 1 - 4 to select your gearbox.

Consider the gearbox maximum nominal (rms) input speed, since this is often a restrictive limit. **For fast acceleration or high duty cycles, use the Full Selection Method.**

Full Selection Method

To ensure all aspects are covered, follow this procedure, using manufacturer's information:

Note that the process may be iterative.

Generally, before commencing, you will need to know: -

- If special reduced backlash is necessary
- Gearbox Style / type. Use section **Gearbox Styles & Types** for guidance.
- Duty cycle rate (start/stop operations per hour)
- Nominal (rms) and peak acceleration torque at output
- Estimated choice of gear ratio = i
(Choose an available ratio, best suited for the system inertia)
- Estimated motor size and rated torque T_m .

Follow the **GEARBOX SELECTION FLOW CHART**, together with the explanations that follow.

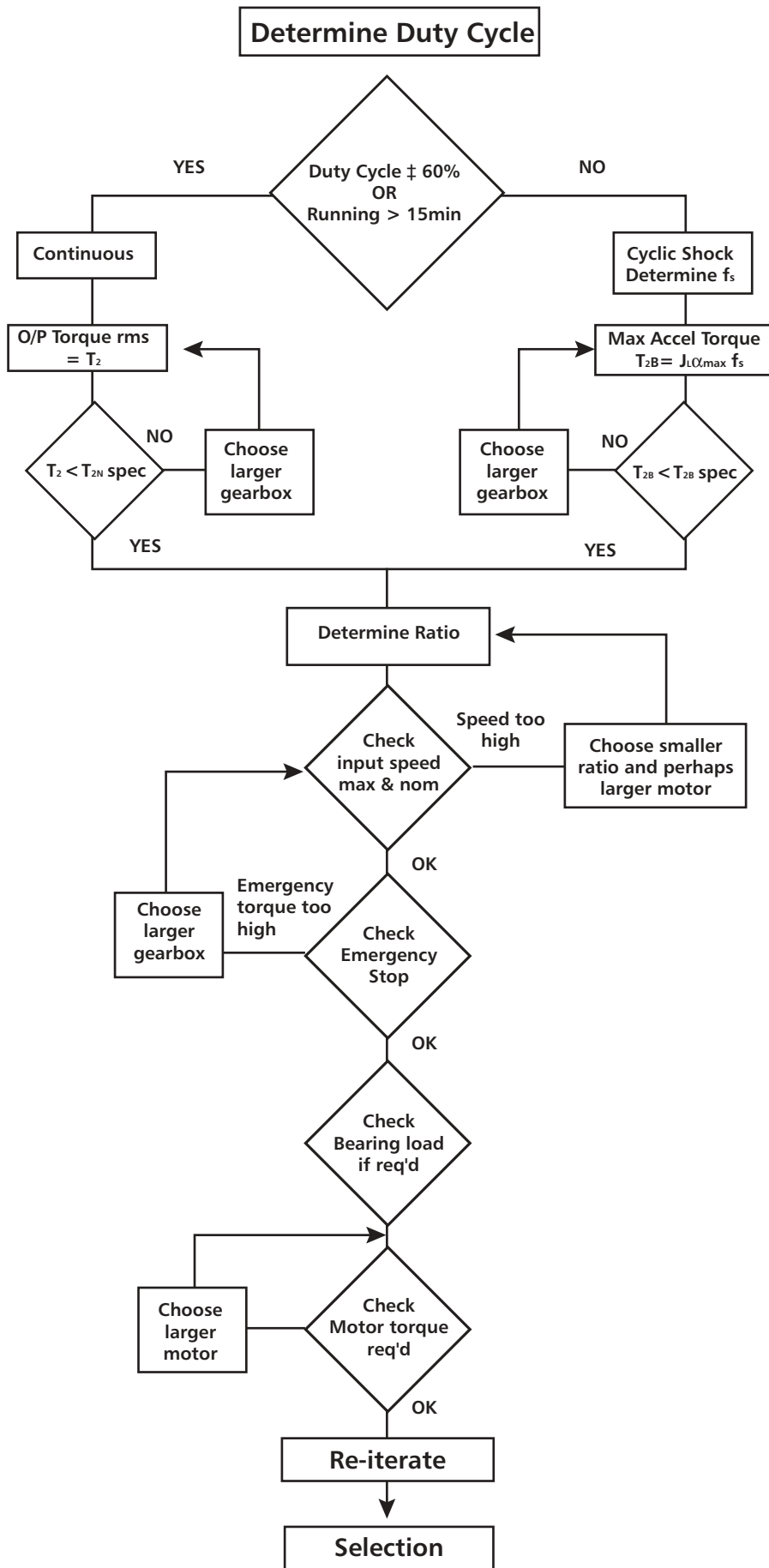

9

Determine Duty Cycle

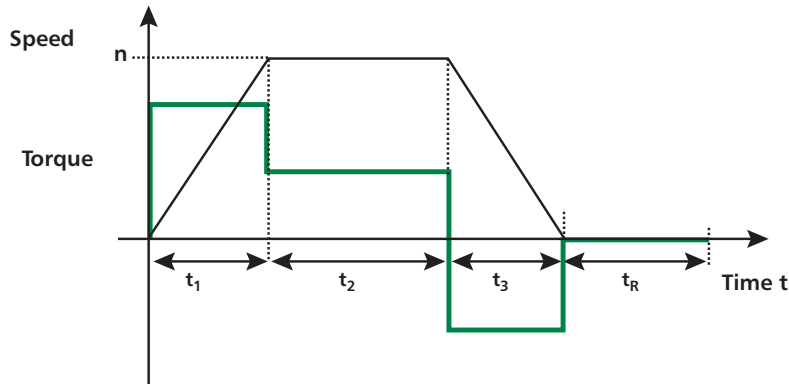

Fig 2 – Speed / torque v time - single stop/start event

Duty Cycle = (Run Time within Cycle Time) / (Cycle Time) x 100%

$$= (t_1 + t_2 + t_3 \dots + t_N) / (t_1 + t_2 + t_3 \dots + t_N + t_R) \times 100\%$$

Cyclic Operation

a) High Duty Cycle De-rating

If the system operation involves stops and starts, calculate the number of stops and starts per hour = Z_h (/h)

If $Z_h > 1000$, determine the shock factor f_s from the chart, Fig 3

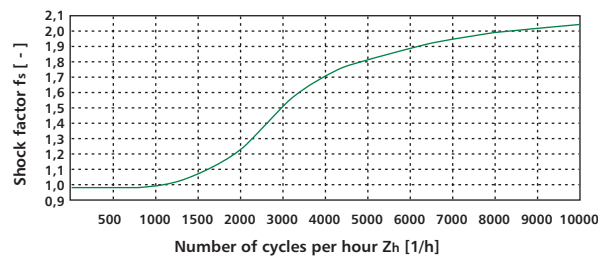

Fig 3

b) Max Acceleration Torque (T_{2B})

f_s must then be used to artificially increase the output acceleration torque requirement.

e.g. max acceleration torque may be given by $T_{2B} = J_L \alpha_{max} f_s$

where J_L = inertia of load (kgm^2)

α_{max} = max load acceleration required (rad/s^2)

and f_s = shock factor. (If $Z_h < 1000$, then $f_s = 1$)

Check that T_{2B} is less than the maximum specified for the gearbox.

Continuous Operation - Nominal Output Torque

Check that the calculated rms torque (T_2) required at load is less than the nominal output torque (T_{2N}) specified for the gearbox.

If ($T_2 > T_{2N}$), select a larger gearbox.

Determine the Ratio (i)

Consider:-

- A high speed motor such as 3000rpm, 4000rpm or even 6000rpm, but do not exceed mean gearbox input speed rating.
- The inertia ratio: reflected load inertia (J_L / i^2) at motor to motor inertia (J_M)

Where $(J_L / i^2) / J_M < 3$ for acceleration $\geq 1000\text{rad/s}^2$

- The required output speed

Check Input Speed (maximum and nominal)

- Check that the gearbox input-speed never exceeds the maximum rating.
- Calculate the mean input speed (n_{1m})

$$n_{1m} = \frac{\text{Distance travelled (forward \& reverse) in one cycle}}{\text{Total cycle time}}$$

for Fig 2,

$$n_{1m} = \frac{(0.5n_1t_1 + n_1t_2 + 0.5n_1t_3)}{(t_1 + t_2 + t_3 + t_4)}$$

Check that $n_{1m} < \text{nominal input speed rating for gearbox } (n_{1N})$

Gearbox temperature will be 90°C , based at T_{2N} , n_{1N} and 20°C ambient.

De-rate n_{1N} by 20% for 40°C and by 40% for 60°C ambient.

If $n_{1m} > n_{1N}$, then choose smaller ratio. A larger motor may be required to produce the torque.

Check Emergency Stop

Emergency stop is permitted only 1000 times in the life of a gearbox. If applicable, calculate deceleration for emergency stop. From load inertia, calculate emergency stop torque.

Ensure that this does not exceed the maximum stated in the manufacturer's information.

Check Bearing Load

Where necessary, check maximum axial and radial loading and tilting moments against quoted maximums.

If this information is not shown, please refer to manufacturer.

Calculate RMS Input Torque

Refer to **Motor Rating for Motor Gearbox Assembly** to calculate gearbox-input RMS torque.

De-rate motor by 5%.

Ensure gearbox-input RMS torque $<$ de-rated motor torque at required RMS speed.

Other Definitions

Torsional Backlash

This is mainly the clearance between the gear teeth. This is measured in arcmins at the output, with the input locked, whilst applying 2% of the maximum acceleration torque.

Torsional Rigidity

Torsional rigidity or stiffness (Nm/arcmin) is a measurement of an applied load at the output, against the angular deflection with the input locked.

A high value of torsional rigidity is desirable especially for stability when a closed-loop system feedback is applied from the output.

Maximum Radial Load

The radial load specified is referenced to a point half way along the output shaft at a speed of 300rpm.

Maximum Tilting Moment

Quantified in Nm, this is the vector amplitude resulting from the Radial and Axial loads applied together

Protection Level

Quoted as IP64, this means totally protected against dust and water sprayed in all directions, limited ingress permitted.

Acoustic Noise Level

Given in dB taken at 3000rpm at a distance of 1m.

- Low ratios are louder

- A 2-stage gearbox is louder than 1-stage

- High torque levels are louder

Motor Rating for Motor-Gearbox Assembly

The motor must be capable of delivering the required torque, so it is important to calculate the torque that the motor is required to deliver.

Additionally, the motor should be de-rated by about 5% if the gearbox is at a high temperature since the conducted heat path via the front flange of the motor is less effective when attached to a hot gearbox.

Torque values used in the following formulae are RMS values, since heating effects are relevant.

Efficiency (η_N)

This is ratio of power out / power in

- Quoted for the gearbox at full load rating and nominal input speed.

Typically, $\eta_N = 97\%$ for 1-stage gearboxes
Or $\eta_N = 94\%$ for 2-stage gearboxes

At a lower torque level and/or lower speed, efficiency will be reduced.

Rated power in = rated power out \div efficiency at nominal output torque

$$n_{1N} \times T_{1N} = (n_{2N} \times T_{2N}) / \eta_N$$

Hence $T_{1N} = T_{2N} / i \cdot \eta_N$ at nominal output torque

Where

T_{1N} = nominal input torque rating

n_{1N} = nominal input speed

T_{2N} = nominal output torque rating

n_{2N} = nominal output speed

η_N = efficiency at nominal output torque

$i = n_{1N} / n_{2N}$ = gearbox ratio

For levels of output torque less than T_{2N} , efficiency is reduced; refer to **Input Torque** and Fig 2.

Input Torque (T_1)

At nominal speed, torque required at gearbox input (T_1) may be approximated by the formula: -

$$(T_1) = T_2 \left(\frac{1}{i\eta_N} - \frac{T_{012}}{T_{2N}} \right) + T_{012} \quad (\text{for } T_2 \leq T_{2N})$$

Where

- T_1 = estimated input torque
- T_2 = actual output torque
- T_{2N} = nominal output torque rating
- T_{012} = no-load torque
- η_N = efficiency at nominal output torque
- i = gearbox ratio

This is shown by the graph in Fig 2.

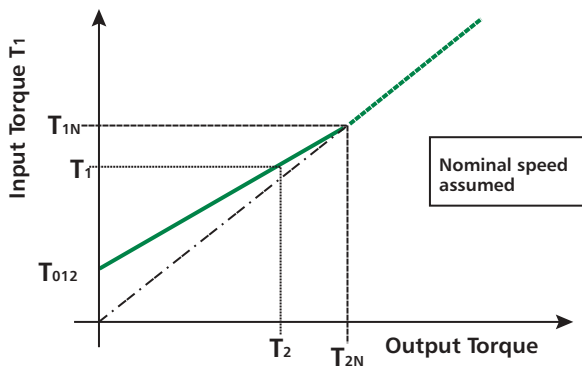

Fig 2 Input Torque

Graph shows that (for short periods), when $T_2 \geq T_N$, it is best to assume that: - $T_1 = T_2 / i\eta_N$

If no-load torque T_{012} is known, then T_1 may be calculated for a given output torque T_2 .

If no-load torque T_{012} is unknown, then estimate T_{012} by the formula shown in **No Load Torque** .

However, it is probable that the input torque T_1 required is close to the value T_N so that the equation $T_{1N} = T_{2N} / i \cdot \eta_N$ will suffice with a margin of adjustment.

No Load Torque (T_{012})

This is the input torque required to turn the gearbox at 3000rpm input speed (or as stated), with no load attached to the gearbox.

For other speeds, multiply T_{012} by the value as shown:-

1000rpm	$T_{012} \times 0.5$
2000rpm	$T_{012} \times 0.75$
3000rpm	$T_{012} \times 1$
4000rpm	$T_{012} \times 1.25$
5000rpm	$T_{012} \times 1.5$
6000rpm	$T_{012} \times 1.75$

Special reduced backlash will increase no-torque to a higher value

Typically, T_{012} is quoted at a 20°C gear-reducer temperature. Note the gearbox must be already "run-in".

If T_{012} is not quoted, estimate a value from the formula: -

$$T_{012} = (T_{2B} \div i) \times (1 - \eta_N) / \eta_N$$

Where T_{2B} = rated output acceleration torque

No-Load Torque For A New Gearbox

When first run, a gearbox will have a higher no load torque than quoted.

In some instances, this may require an input torque higher than that of the motor rating and may therefore cause drive trips. To avoid this circumstance, the gearbox should be run-in on no load and lower speed for 24 hours.

Gearboxes - Quick Select Tables

Tables 1- 4 show UM motor sizes tabulated against gearbox with standard adaptor sizes, and give a good basic guide for compatibility.

Tables 1 – 4 do not encompass all parameters.
System designers must ensure that motor and gearbox parameters are suitable for the application.

Alpha Gearboxes

Alpha gearboxes are designated by type and size,

e.g. SP100 has 100mm g6 referencing cylinder to match hole in mounting support.

Body diameters may exceed this value

For full dimension details refer to manufacturer's data

LP sizes of 50; 70; 90; 120; 155 have a circular housing corresponding to mm dimensions.

ZF Gearboxes

ZF gearboxes are designated by type and nominal output torque.

e.g. PG25 has a 25Nm nominal output torque rating and is compatible to the SP.

Frame Size	Speed	Shaft D mm	stall Nm	R 4:1	R 5:1	R 7:1	R 10:1
55MMA300	3000	9	1.4	PG25	PG25	PG25	PG25
55MMB300	3000	11		PG25	PG25	PG25	PG25
55MMC300	3000	11		PG25	PG25	PG25	PG25
55MMA500	5000	11		PG25	PG25	PG25	PG25
55MMB500	5000	11		PG25	PG25	PG25	PG25
75UMA	2000	11	1.2	PG25	PG25	PG25	PG25
75UMA	3000	11		PG25	PG25	PG25	PG25
75UMA	4000	11		PG25	PG25	PG25	PG25
75UMB	2000	14	2.2	PG25	PG25	PG25	PG100
75UMB	3000	14		PG25	PG25	PG25	PG50
75UMB	4000	14		PG25	PG25	PG25	PG100
75UMC	2000	14	3.1	PG25	PG25	PG25	PG100
75UMC	3000	14		PG25	PG25	PG25	PG100
75UMC	4000	14		PG25	PG25	PG25	PG100
75UMD	2000	14	3.9	PG25	PG25	PG25	PG100
75UMD	3000	14		PG25	PG25	PG25	PG100
75UMD	4000	14		PG25	PG25	PG25	PG100
95UMA	2000	14	2.3	PG25	PG25	PG25	PG25
95UMA	3000	14		PG25	PG25	PG25	PG25
95UMA	4000	14		PG25	PG25	PG25	PG25
95UMB	2000	19	4.3	PG100	PG100	PG100	PG100
95UMB	3000	19		PG100	PG100	PG100	PG100
95UMB	4000	19		PG100	PG100	PG100	PG100
95UMC	2000	19	5.9	PG100	PG100	PG100	PG100
95UMC	3000	19		PG100	PG100	PG100	PG100
95UMC	4000	19		PG100	PG100	PG100	PG100
95UMD	2000	19	7.5	PG100	PG100	PG100	PG100
95UMD	3000	19		PG100	PG100	PG100	PG100
95UMD	4000	19		PG100	PG100	PG100	PG100
95UME	2000	19	9.0	PG100	PG100	PG100	PG100
95UME	3000	19		PG100	PG100	PG100	PG100
95UME	4000	19		PG100	PG100	PG100	PG100
115UMA	2000	19	3.5	PG100	PG100	PG100	PG100
115UMA	3000	19		PG100	PG100	PG100	PG100
115UMA	4000	19		PG100	PG100	PG100	PG100
115UMB	2000	19	6.6	PG100	PG100	PG100	PG100
115UMB	3000	19		PG100	PG100	PG100	PG100
115UMB	4000	19		PG100	PG100	PG100	PG100
115UMC	2000	19	9.4	PG100	PG100	PG100	PG100
115UMC	3000	19		PG100	PG100	PG100	PG100
115UMC	4000	19		PG100	PG100	PG100	PG100
115UMD	2000	24	12.4	PG100	PG100	PG100	PG100
115UMD	3000	24		PG100	PG100	PG100	PG100
115UMD	4000	24		PG100	PG100	PG100	PG100
115UME	2000	24	15.3	PG100	PG100	PG100	PG200
115UME	3000	24		PG100	PG100	PG100	PG200
115UME	4000	24		PG100	PG100	PG100	PG200
142UMA	2000	24	6.3	PG100	PG100	PG100	PG100
142UMA	3000	24		PG100	PG100	PG100	PG100
142UMA	4000	24		PG100	PG100	PG100	PG100
142UMB	2000	24	10.8	PG100	PG100	PG100	PG100/PG200
142UMB	3000	24		PG100	PG100	PG100	PG100/PG200
142UMB	4000	24		PG100	PG100	PG100	PG100/PG200
142UMC	2000	24	15.3	PG100	PG100	PG100/PG200	PG200
142UMC	3000	24		PG100	PG100	PG100/PG200	PG200
142UMC	4000	24		PG100	PG100	PG100/PG200	PG200
142UMD	2000	24	19.8	PG100	PG100	PG200	PG200
142UMD	3000	24		PG100	PG100	PG200	PG200
142UMD	4000	24		PG100	PG100	PG200	PG200
142UME	2000	24	23.4	PG100	PG200	PG200	PG200
142UME	3000	24		PG100	PG200	PG200	PG200
142UME	4000	24		PG100	PG200	PG200	PG200
190UMA	2000	32	21.8	PG200	PG200	PG500	PG500
190UMA	3000	32		PG200*	PG200	PG500	PG500
190UMB	2000	32	41.1	PG200	PG500	PG500	PG500
190UMB	3000	32		PG200*	PG500	PG500	PG500
190UMC	2000	32	58.7	PG500	PG500	PG500	PG500/PG1200
190UMC	3000	32		PG200*	PG500	PG500	PG500/PG1200
190UMD	2000	32	73.2	PG500	PG500	PG500/PG1200	PG1200*
190UMD	3000	32		PG200*	PG500	PG500/PG1200	PG1200*

Table 3 - Unimotor & ZF Gearboxes - PG Selection

Frame Size	Speed	Shaft D mm	stall Nm	R 3:1	R 4:1	R 5:1	R 6:1	R 8:1	R 10:1	R 12:1	R 15:1
55MMA	3000	9	1.4	WT35	WT35	WT35	WT35	WT35	WT35	WT35	WT35
55MMB	3000	11		WT35	WT35	WT35	WT35	WT35	WT35	WT35	WT35
55MMC	3000	11		WT35	WT35	WT35	WT35	WT35	WT35	WT35	WT35
55MMA	5000	11		WT35	WT35	WT35	WT35	WT35	WT35	WT35	WT35
55MMB	5000	11		WT35	WT35	WT35	WT35	WT35	WT35	WT35	WT35
75UMA-	2000	11	1.2	WT35	WT35	WT35	WT35	WT35	WT35	WT35	WT35
75UMA-	3000	11		WT35	WT35	WT35	WT35	WT35	WT35	WT35	WT35
75UMA-	4000	11		WT35	WT35	WT35	WT35	WT35	WT35	WT35	WT35
75UMB-	2000	14	2.2	WT35	WT35	WT35	WT35	WT35	WT35	WT70	WT70
75UMB-	3000	14		WT35	WT35	WT35	WT35	WT35	WT35	WT70	WT70
75UMB-	4000	14		WT35	WT35	WT35	WT35	WT35	WT35	WT70	WT70
75UMC-	2000	14	3.1	WT35	WT35	WT35	WT35	WT35	WT35	WT70	WT70
75UMC-	3000	14		WT35	WT35	WT35	WT35	WT35	WT35	WT70	WT70
75UMC-	4000	14		WT35	WT35	WT35	WT35	WT35	WT35	WT70	WT70
75UMD-	2000	14	3.9	WT35	WT35	WT35	WT35	WT35	WT35	WT70	WT70
75UMD-	3000	14		WT35	WT35	WT35	WT35	WT35	WT35	WT70	WT70
75UMD-	4000	14		WT35	WT35	WT35	WT35	WT35	WT35	WT70	WT70
95UMA	2000	14	2.3	WT35	WT35	WT35	WT35	WT35	WT35	WT70	WT70
95UMA	3000	14		WT35	WT35	WT35	WT35	WT35	WT35	WT70	WT70
95UMA	4000	14		WT35	WT35	WT35	WT35	WT35	WT35	WT70	WT70
95UMB	2000	19	4.3	WT70	WT70	WT70	WT70	WT70	WT70	WT70	WT70
95UMB	3000	19		WT70	WT70	WT70	WT70	WT70	WT70	WT70	WT70
95UMB	4000	19		WT70	WT70	WT70	WT70	WT70	WT70	WT70	WT70
95UMC	2000	19	5.9	WT70	WT70	WT70	WT70	WT70	WT70	WT140	WT140
95UMC	3000	19		WT70	WT70	WT70	WT70	WT70	WT70	WT140	WT140
95UMC	4000	19		WT70	WT70	WT70	WT70	WT70	WT70	WT140	WT140
95UMD	2000	19	7.5	WT70	WT70	WT70	WT70	WT70	WT70	WT140	WT140
95UMD	3000	19		WT70	WT70	WT70	WT70	WT70	WT70	WT140	WT140
95UMD	4000	19		WT70	WT70	WT70	WT70	WT70	WT70	WT140	WT140
95UME	2000	19	9.0	WT70	WT70	WT70	WT70	WT70	WT70	WT140	WT260
95UME	3000	19		WT70	WT70	WT70	WT70	WT70	WT70	WT140	WT260
95UME	4000	19		WT70	WT70	WT70	WT70	WT70	WT70	WT140	WT260
115UMA	2000	19	3.5	WT70	WT70	WT70	WT70	WT70	WT70	WT140	WT140
115UMA	3000	19		WT70	WT70	WT70	WT70	WT70	WT70	WT140	WT140
115UMA	4000	19		WT70	WT70	WT70	WT70	WT70	WT70	WT140	WT140
115UMB	2000	19	6.6	WT70	WT70	WT70	WT70	WT70	WT70	WT140	WT260
115UMB	3000	19		WT70	WT70	WT70	WT70	WT70	WT70	WT140	WT260
115UMB	4000	19		WT70	WT70	WT70	WT70	WT70	WT70	WT140	WT260
115UMC	2000	19	9.4	WT70	WT70	WT70	WT70	WT70	WT70	WT260	WT260
115UMC	3000	19		WT70	WT70	WT70	WT70	WT70	WT70	WT260	WT260
115UMC	4000	19		WT70	WT70	WT70	WT70	WT70	WT70	WT260	WT260
115UMD	2000	24	12.4	WT140	WT140	WT140	WT140	WT140	WT140	WT260	WT260*
115UMD	3000	24		WT140	WT140	WT140	WT140	WT140	WT140	WT260	WT260*
115UMD	4000	24		WT140	WT140	WT140	WT140	WT140	WT140	WT260	WT260*
115UME	2000	24	15.3	WT140	WT140	WT140	WT140	WT140	WT140	WT260*	WT700
115UME	3000	24		WT140	WT140	WT140	WT140	WT140	WT140	WT260*	WT700
115UME	4000	24		WT140	WT140	WT140	WT140	WT140	WT140	WT260*	WT700
142UMA	2000	24	6.3	WT140	WT140	WT140	WT140	WT140	WT140	WT140	WT260
142UMA	3000	24		WT140	WT140	WT140	WT140	WT140	WT140	WT140	WT260
142UMA	4000	24		WT140	WT140	WT140	WT140	WT140	WT140	WT140	WT260
142UMB	2000	24	10.8	WT140	WT140	WT140	WT140	WT140	WT140	WT260	WT260*
142UMB	3000	24		WT140	WT140	WT140	WT140	WT140	WT140	WT260	WT260*
142UMB	4000	24		WT140	WT140	WT140	WT140	WT140	WT140	WT260	WT260*
142UMC	2000	24	15.3	WT140	WT140	WT140	WT140	WT140	WT260	WT700	WT700
142UMC	3000	24		WT140	WT140	WT140	WT140	WT140	WT260	WT700	WT700
142UMC	4000	24		WT140	WT140	WT140	WT140	WT140	WT260	WT700	WT700
142UMD	2000	24	19.8	WT140	WT140	WT140	WT140	WT260	WT700	WT700	WT700
142UMD	3000	24		WT140	WT140	WT140	WT140	WT260	WT700	WT700	WT700
142UMD	4000	24		WT140	WT140	WT140	WT140	WT260	WT700	WT700	WT700
142UME	2000	24	23.4	WT140	WT140	WT140	WT260	WT260	WT260*	WT700	WT700
142UME	3000	24		WT140	WT140	WT140	WT260	WT260	WT260*	WT700	WT700
142UME	4000	24		WT140	WT140	WT140	WT260	WT260	WT260*	WT700	WT700
190UMA	2000	32	21.8	WT260	WT260	WT260	WT260	WT260	WT260	WT260*	WT700
190UMA	3000	32		WT260	WT260	WT260	WT260	WT260	WT260	WT260*	WT700
190UMB	2000	32	41.1	WT260	WT260	WT260	WT260	WT700	WT700	WT700	WT700
190UMB	3000	32		WT260	WT260	WT260	WT260	WT700	WT700	WT700	WT700
190UMC	2000	32	59.7	WT260	WT260	WT260	WT700	WT700	WT700	WT1400	WT1400
190UMC	3000	32		WT260	WT260	WT260	WT700	WT700	WT700	WT1400	WT1400*
190UMD	2000	32	73.2	WT260	WT700	WT700	WT700	WT700	WT700*	WT1400	WT1400*
190UMD	3000	32		WT260	WT700	WT700	WT700	WT700	WT700*	WT1400*	WT1400*

Table 4 - Unimotor & ZF Gearboxes - WT 90° Selection

Alpha SP Gearbox Product details

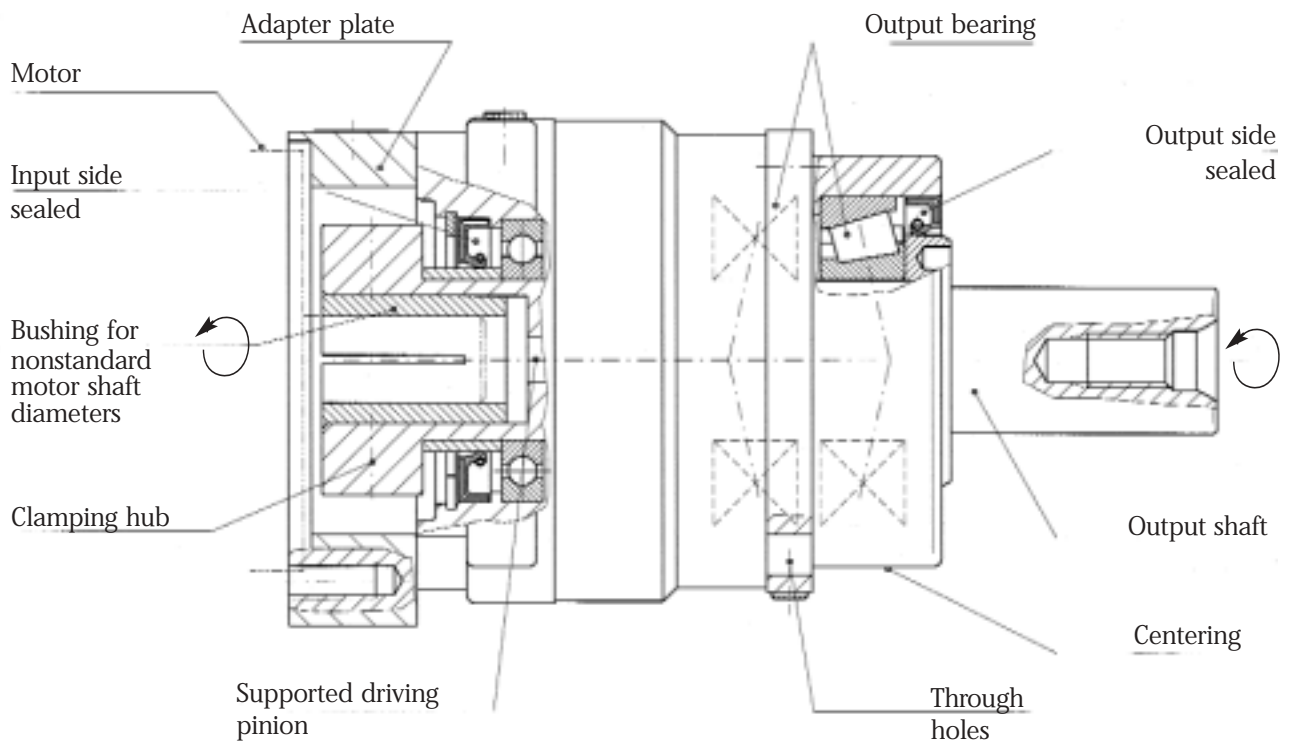

9

SP Gearboxes - Technical Data

Size				SP 060	SP 075	SP 100	SP 140	SP 180	SP 210	SP 240	
max. Acceleration Torque 1)	T_{2B}	Nm	$i = 4-7$ $i = 16-70$	40	100	250	500	1100	1900	3400	
Emergency Stop 2)	T_{2Not}	Nm	$i = 4-7$ $i = 16-70$ $i = 10/100$	100	250	625	1250	2750	4750	8500	
Nominal Output Torque	T_{2N}	Nm	$i = 4-7$ $i = 16-70$ $i = 10/100$	25	70	170	360	550	1000	1700	
max. Input Speed	n_{1Max}	rpm	1-stage 2-stage	6000	6000	4500	4000	3500 4000	2500 3500	2200 3500	
Nominal Input Speed 3)	n_{1N}	rpm	$i = 4/5$ $i = 7/10$ $i = 16$ $i = 50$ $i = 100$	3300	2900	2500	2100	1500	1200	1000	
Ratios	i		1-stage 2-stage	4 / 5 / 7 / 10 16 / 20 / 28 / 40 / 50 / 70 / 100							
Torsional Backlash	Standard Reduced	j_t	arcmin	1-stage 2-stage		≤ 6 ≤ 8		≤ 4 ≤ 6			
Torsional Rigidity	C_{t21}	Nm/arcmin		3	8	24	45	144	≈ 225	≈ 350	
max. Axial Load 4)	F_{2AMax}	N		2300	3200	5400	9400	13500	22500	27800	
max. Radial Load 4)	F_{2RMax}	N		2600	3800	6000	9000	14000	18000	27000	
max. Tilting Mom.	M_{2KMax}	Nm		133	225	464	907	1523	2430	4226	
No-load Running Torque 5) ($n_1 = 3000$ rpm)	T_{012}	Nm	$i = 4$ $i = 16$ $i = 100$	0.5 0.3 0.2	0.9 0.7 0.4	0.25 1.7 0.7	3.9 2.4 1.1	6.2			
Service Life 6)	L_h	h		> 20.000							
Efficiency with full load	η	%		1-stage 2-stage		≥ 97 ≥ 94					
Weight	m	kg		1-stage 2-stage		1.5 1.8		2.8 3.1		6.2 7.1	
Lubrication	Synthetic oil viscosity ISO VG220										
Paint	Blue RAL 5002										
Mounting Position	advised with your order										
Permissible Gear Reducer Temp. °C	-10°C to + 90°C										
Direction of Rotation	Motor and gear reducer same direction										
Degree of Gearbox Protection	IP 64										
Noise Level (n1 = 3000 rpm)	L_{PA}	dB(A)		≤ 68			≤ 70			≤ 72	

- 1) 1000 cycles per hour.
- 2) 1000 times during the service life.
- 3) at 20°C ambient temperature (if you have higher ambient temperature, please reduce the n_{1N} speed).
- 4) applied to the shaft centre.
- 5) at 20°C gear reducer temperature.
- 6) service life may be reduced for abnormal loads.

Conversion Table:

1 Nm	= 8.85 in. lb.
1 kgcm ²	= 8.85 x 10 ⁻⁴ in. lb.s ²
1 N	= .225 lb _f
1 kg	= 2.205 lb.

SP Gearboxes - Dimensions

Dimensions [mm]

1 mm = 0.03937 in.

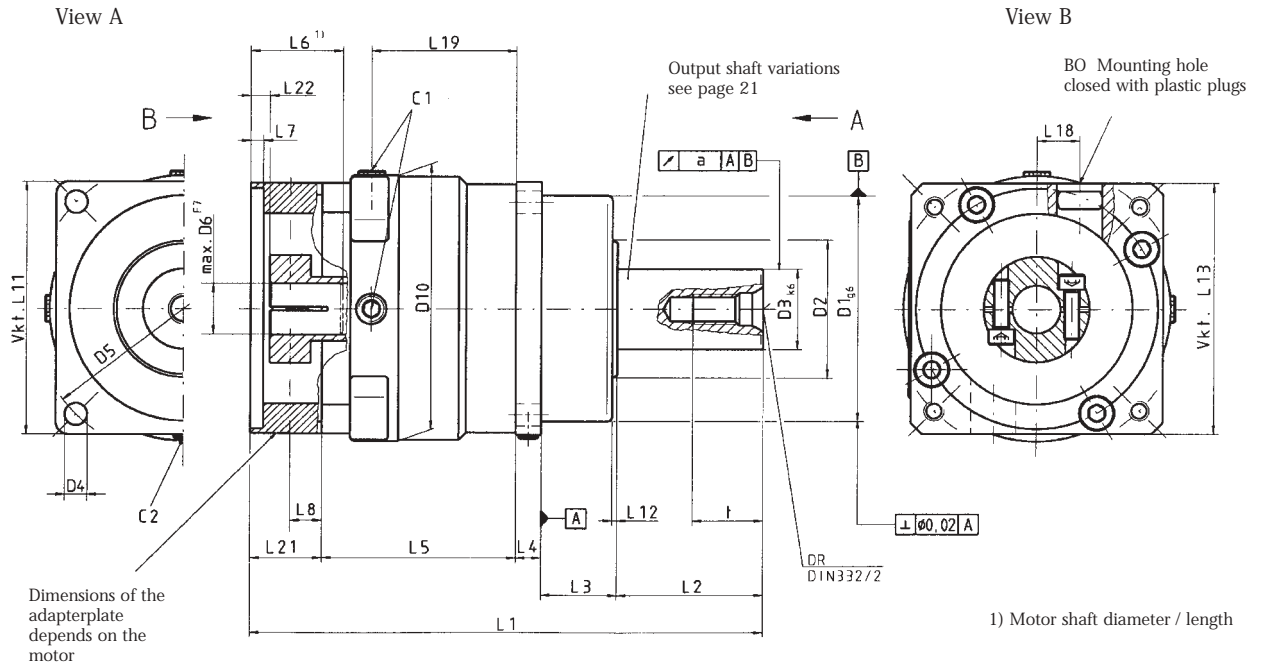

Size	SP 060	SP 075	SP 100	SP 140	SP 180	SP 210	SP 240
Gear Stages	1 / 2	1 / 2	1 / 2	1 / 2	1 / 2	1 / 2	1 / 2
a	0.03	0.03	0.035	0.04	0.04	0.04	0.04
BO	8	15	18	20	20	20	30 / 20
C1	1xM8x1	1xM8x1	3xM12x1.5	3xM12x1.5	3xM12x1.5	3xM12x1.5	3xM12x1.5
C2	-	-	1xM8x1	1xM8x1	1xM8x1	1xM8x1	1xM12x1.5
DR	M5	M8	M12	M16	M20	M20	M20
D1 g6	60	70	90	130	160	180	200
D2	30	38	55	70	90	120	130
D3 k6	16	22	32	40	55	75	85
D4	5.5	6.6	9	11	13	17	17
D5	68	85	120	165	215	250	290
D6 ³⁾ F7	14	19	32	38	48 / 38	55 / 48	60 / 48
D10 + 1	61.5	82	106	140	193	212	242
L1 ^{2) 3)} ± 2	129 / 149	156 / 182.5	202 / 234.5	256.5 / 296.5	297 / 315.5	350 / 397	436 / 453.5
L2	28	36	58	82	82	105	130
L3	20	20	30	30	30	38	40
L4	6	7	10	12	15	17	20
L5	60 / 80	71 / 97.5	76 / 108.5	102 / 142	132.5 / 158	152.5 / 199.5	200 / 226
L6 ³⁾ min.	15	23	30	32	45 / 32	45	55 / 45
L6 ³⁾ max.	30	40	50	60	82 / 60	82	110 / 82
L7 ³⁾ + 0.5	4	4	5	6	6	6	8 / 6
L8	5.6	8.5	10	12.5	13 / 12.5	13	18 / 13
L11 ± 1	62	76	101	141	182	212	242
L12	2	2	2	3	3	3	3
L13 ³⁾ ± 1 min.	60	80	100	140	190 / 140	190	260 / 190
L18	10	12	17	19	29 / 19	29	40 / 29
L19	47.5 / 67.5	57 / 83.5	56 / 88.5	74.5 / 114.5	100.5 / 130.5	114.5 / 167.5	147 / 194
L21 ³⁾	15	22	28	30.5	37.5 / 30.5	37.5	46 / 37.5
L22 ³⁾ + 0.9	3.7	6.2	6.7	5.2	9.3 / 5.2	9.2 / 9.3	12.6 / 9.3
t	12.5	19	28	36	42	42	42

²⁾ If you have involute toothing at the output shaft, L1 will change.

³⁾ Dimensions depend on the motor.

SP Gearboxes - Inertia

1 kgcm² = 8.85 x 10⁻⁴ in. lb.s²
 1 mm = 0.03937 in.
 1 Nm = 8.85 in.lb.

Mass moments of inertia J₁ [kgcm²] applies to the input

Gear reducer size	Motor shaft diameter [mm]	Ratio i single-stage				Ratio i two-stage						
		4	5	7	10	16	20	28	40	50	70	100
SP 060	≤ 11	0.14	0.14	0.13	0.12	0.15	0.15	0.15	0.12	0.12	0.12	0.12
	> 11 ≤ 14	0.17	0.17	0.16	0.15	0.19	0.19	0.19	0.15	0.15	0.15	0.15
SP 075	≤ 11	0.52	0.44	0.38	0.35	0.48	0.47	0.47	0.34	0.34	0.34	0.34
	> 11 ≤ 14	0.57	0.49	0.43	0.40	0.53	0.52	0.52	0.39	0.39	0.39	0.39
	> 14 ≤ 19	0.63	0.55	0.49	0.46	0.59	0.58	0.58	0.45	0.45	0.45	0.45
SP 100	≤ 14	1.9	1.6	1.3	1.2	1.7	1.7	1.7	1.1	1.1	1.1	1.1
	> 14 ≤ 19	2.0	1.7	1.4	1.3	1.8	1.8	1.8	1.2	1.2	1.2	1.2
	> 19 ≤ 24	2.7	2.4	2.1	2.0	2.5	2.5	2.5	1.9	1.9	1.9	1.9
	> 24 ≤ 28	3.5	3.2	2.9	2.8	3.3	3.3	3.3	2.7	2.7	2.7	2.7
	> 28 ≤ 32	4.6	4.3	4.0	3.9	4.4	4.4	4.4	3.8	4.8	3.8	3.8
SP 140	≤ 19	5.0	4.1	3.3	2.8	4.4	4.4	4.4	2.7	2.7	2.7	2.7
	> 19 ≤ 24	5.7	4.8	4.0	3.5	5.1	5.1	5.1	3.4	3.4	3.4	3.4
	> 24 ≤ 32	8.4	7.5	6.7	6.2	7.8	7.8	7.8	6.1	6.1	6.1	6.1
	> 32 ≤ 35	8.2	7.3	6.5	6.0	7.6	7.6	7.6	5.9	5.9	5.9	5.9
	> 35 ≤ 38	10.0	9.1	8.3	7.8	9.4	9.4	9.4	7.7	7.7	7.7	7.7
SP 180 2-stage	≤ 19	-	-	-	-	5.0	4.8	4.6	2.8	2.8	2.7	2.7
	> 19 ≤ 24	-	-	-	-	5.7	5.5	5.3	3.5	3.5	3.4	3.4
	> 24 ≤ 32	-	-	-	-	8.4	8.2	8.0	6.2	6.2	6.1	6.1
	> 32 ≤ 35	-	-	-	-	8.2	8.0	7.8	6.0	6.0	5.9	5.9
	> 35 ≤ 38	-	-	-	-	10.0	9.8	9.6	7.8	7.8	7.7	7.7
SP 180 1-stage	≤ 32	30.6	24.9	20.0	17.4	-	-	-	-	-	-	-
	> 32 ≤ 38	31.7	26.0	21.1	18.5	-	-	-	-	-	-	-
	> 38 ≤ 48	36.2	30.5	25.6	23.0	-	-	-	-	-	-	-
SP 210 2-stage	≤ 32	-	-	-	-	36.3	34.5	32.3	23.1	21.9	20.2	18.9
	> 32 ≤ 38	-	-	-	-	37.4	35.6	33.4	24.3	23.0	21.3	20.0
	> 38 ≤ 48	-	-	-	-	42.0	40.2	37.9	28.8	27.6	25.8	24.6
SP 210 1-stage	≤ 55	75.8	63.5	52.9	47.1	-	-	-	-	-	-	-
SP 240 2-stage	≤ 32	-	-	-	-	47.3	43.1	37.5	32.4	29.5	24.9	21.4
	> 32 ≤ 38	-	-	-	-	48.4	44.2	38.6	33.6	30.6	26.0	22.5
	> 38 ≤ 48	-	-	-	-	53.0	48.8	43.2	38.1	35.1	30.6	27.1
SP 240 1-stage	≤ 60	146.3	119.9	96.4	83.1	-	-	-	-	-	-	-

Alpha LP Gearbox Product Details

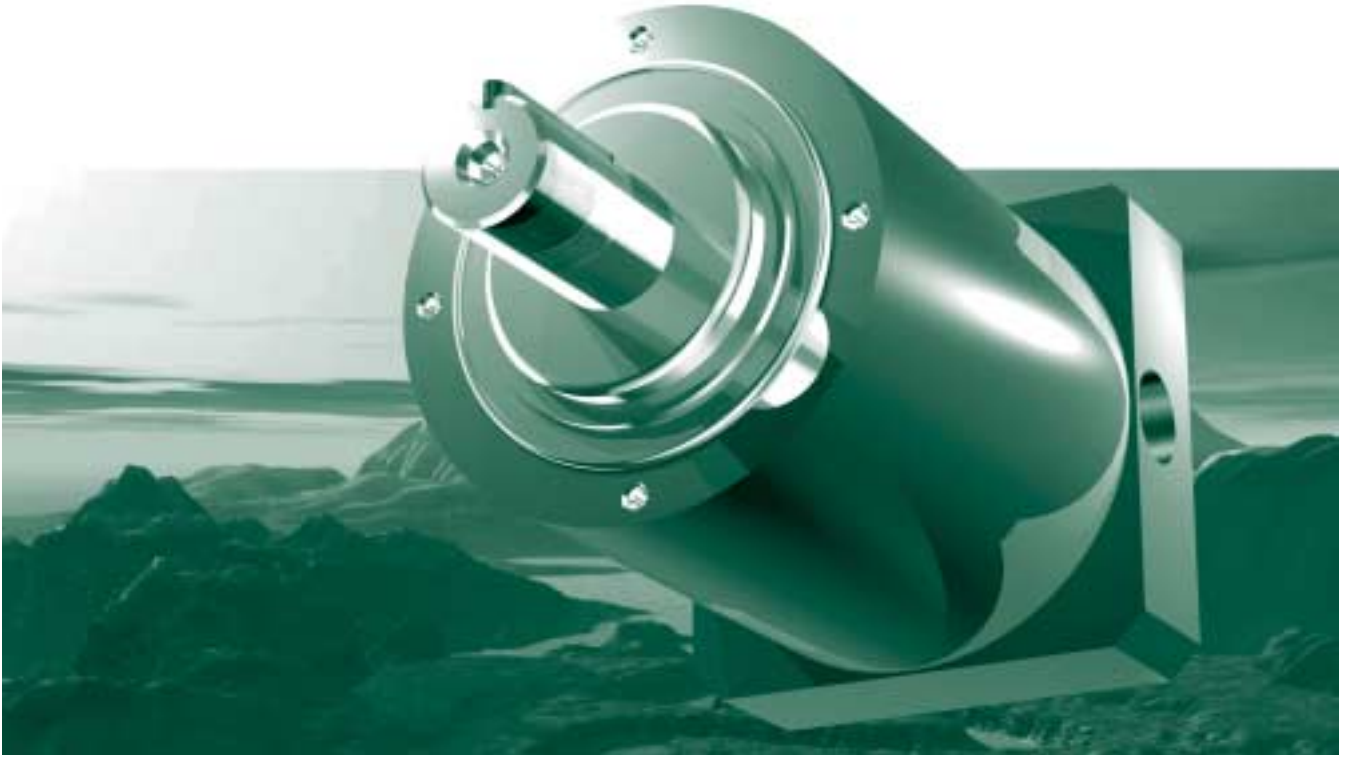

9

LP Gearboxes - Technical Data

Technical Data

Size				LP050	LP070	LP090	LP120	LP155
max. Acceleration Torque ¹⁾	T _{2B}	Nm (in.lb)	ratio i = 5/25/50	11,5(102)	32 (283)	80 (708)	200 (1770)	400 (3540)
			ratio i = 3*/10/15* 30*/100	10,5(93)	29 (256)	72 (637)	180 (1593)	320 (2832)
Peak Output Torque ²⁾	T _{2Not}	Nm (in.lb)		26(230)	75 (664)	190 (1682)	480 (4248)	1000 (8850)
Nominal Output Torque ³⁾	T _{2N}	Nm (in.lb)	ratio i = 5/25/50	5,7(50)	16 (141)	40 (354)	100 (885)	290 (2566)
			ratio i = 3*/10/15* 30*/100	5,2(46)	15 (132)	35 (309)	90 (796)	170 (1504)
Ratio	i		1-stage	3*/5/10				
			2-stage	15*/25/30*/50/100				
max. Radial Load ⁴⁾	F _{2RMax}	N (lb _f)		650(146)	1450 (326)	2400 (540)	4600 (1035)	7500 (1687)
max. Axial Load ⁴⁾	F _{2AMax}	N (lb _f)		700(158)	1550 (349)	1900 (428)	4000 (900)	6000 (1350)
Torsional Rigidity	C _{i21}	Nm(in.lb)/ arcmin	ratio i = 5/25/50	0,9(8)	3,3 (29)	9 (80)	24 (212)	55 (484)
			ratio i = 3*/10/15* 30*/100	0,75(6,6)	2,8 (25)	7,5 (66)	20,5 (181)	44 (387)
Torsional Backlash	j _i	arcmin	1-stage	≤ 12				
			2-stage	≤ 15				
Nominal Input Speed	n _{1N}	min ⁻¹ (rpm)		4000	3700	3400	2600	2000
max. Input Speed	n _{1Max}	min ⁻¹ (rpm)		8000	6000	6000	4800	3600
No-load running Torque at Nominal Input Speed	T ₀₁₂	Nm (in. lb)		≤ 0,05 (≤ 0,44)	≤ 0,14 (≤ 1,24)	≤ 0,38 (≤ 3,37)	≤ 0,8 (≤ 7,1)	≤ 2,5 (≤ 22,1)
Average Lifetime	L _n	h		20.000 h				
Efficiency	η	%	1-stage	> 97				
			2-stage	> 95				
Mass Moments of Inertia	J _i	kgcm ² (in.lbs ²)	1-stage	0,059 (0,000052)	0,28 (0,00025)	1,77 (0,0016)	5,42 (0,0048)	25,73 (0,022)
			2-stage	0,055 (0,000049)	0,28 (0,00025)	1,77 (0,0016)	5,49 (0,0049)	5,33 (0,0047)
Weight	m	kg (lb)	1-stage	0,77 (1,70)	1,9 (4,19)	4,1 (9,04)	9,0 (19,85)	17,5 (38,59)
			2-stage	0,95 (2,09)	2,2 (4,85)	5,1 (11,25)	11,2 (24,7)	21 (46,2)
Lubrication				Fließfett/Flow Grease				
Primer				RAL 5002				
Mounting Position				beliebig/any				
Degree of Protection				IP 64				
Noise Level (n ₁ = 3000 rpm)	L _{PA}	dB (A)		≤ 68	≤ 70	≤ 72	≤ 74	≤ 75

- 1) Max. Acceleration Torque for cycle operation
 - 2) Peak Output Torque for emergency stop (max. 1000 times)
 - 3) Nominal Output Torque for continuous operation
 - 4) Load applied to center of output shaft, at 100 rpm
- * Ratio i = 3/15/30 only for LP 70/90/120

Continuous Operation (S1)

The S1-operation is permitted at nominal speed and nominal output torque. If the gearbox runs continuously for more than 15 minutes or the duty cycle is greater than 60%, use the continuous or S1 operation specifications. These specifications are defined as nominal output torque and nominal input speed. A gearbox temperature of 90°C should not be exceeded. With an S1 application the motor can overheat the gearbox. Please refer to motor manufacturers maximum motor temperature

LP Gearboxes - Dimensions

Dimensions LP-Gear reducer

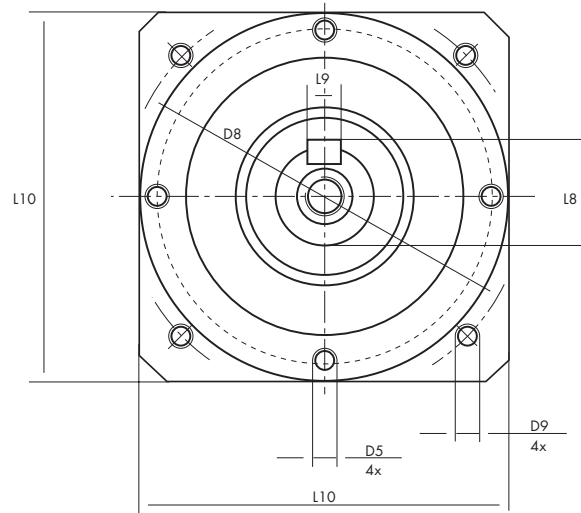

View on 'A'

Dimensions for Motor mounting [mm (in.)]

Size	LP 050	LP 070	LP 090
D7 Pilot clearance bore	*	*	*
D8 Bolt circle	*	*	*
D9 Mounting thread	*	*	*
D10 max. Motor shaft	11 (0,4331)	16 (0,6299)	24 (0,9448)
L10 min. Mounting plate +/-1 (+/-0,039)	50 (1,9685)	70 (2,7559)	90 (3,5433)
L11 Mounting thread depth	min. 1,8 x D9		
L12 Depth of clearance bore	3,5 (0,1378)	4 (0,1575)	5 (0,1969)
L13 Location of mounting bore	6 (0,2362)	5,6 (0,2205)	8,5 (0,3346)
L14 min. Motor shaft length	13 (0,5118)	15 (0,5906)	21 (0,8268)
L14 max. Motor shaft length	20 (0,7874) 25 (0,9843)	23 (0,9055) 30 (1,1811)	30 (1,1811) 40 (1,5748)
L15 Mounting plate thickness •	14 (0,5512) 19 (0,7480)	15 (0,5906) 22 (0,8661)	22 (0,8661) 32 (1,2598)

• two different kinds of mounting plate thicknesses as standard - depending on motor shaft length

Size	LP 120	LP 155 1-stage	LP 155 2-stage
D7 Pilot clearance bore	*	*	*
D8 Bolt circle	*	*	*
D9 Mounting thread	*	*	*
D10 max. Motor shaft	32 (1,2598)	42 (1,6535)	32 (1,2598)
L10 min. Mounting plate +/-1 (+/-0,039)	120 (4,7244)	150 (5,9055)	120 (4,7244)
L11 Mounting thread depth	min. 1,8 x D9		
L12 Depth of clearance bore	8 (0,3150)	6 (0,2362)	8 (0,3150)
L13 Location of mounting bore	10 (0,3937)	16,5 (0,6490)	10 (0,3937)
L14 min. Motor shaft length	28 (1,1024)	35 (1,3779)	28 (1,1024)
L14 max. Motor shaft length	40 (1,5748) 50 (1,9685)	50 (1,9685) 60 (2,3622)	40 (1,5748) 50 (1,9685)
L15 Mounting plate thickness	28 (1,1024) 38 (1,4961)	36 (1,3779) 46 (1,7716)	28 (1,1024) 38 (1,4961)

*Dimensions depend on motor to be mounted

LP Gearboxes - Dimensions

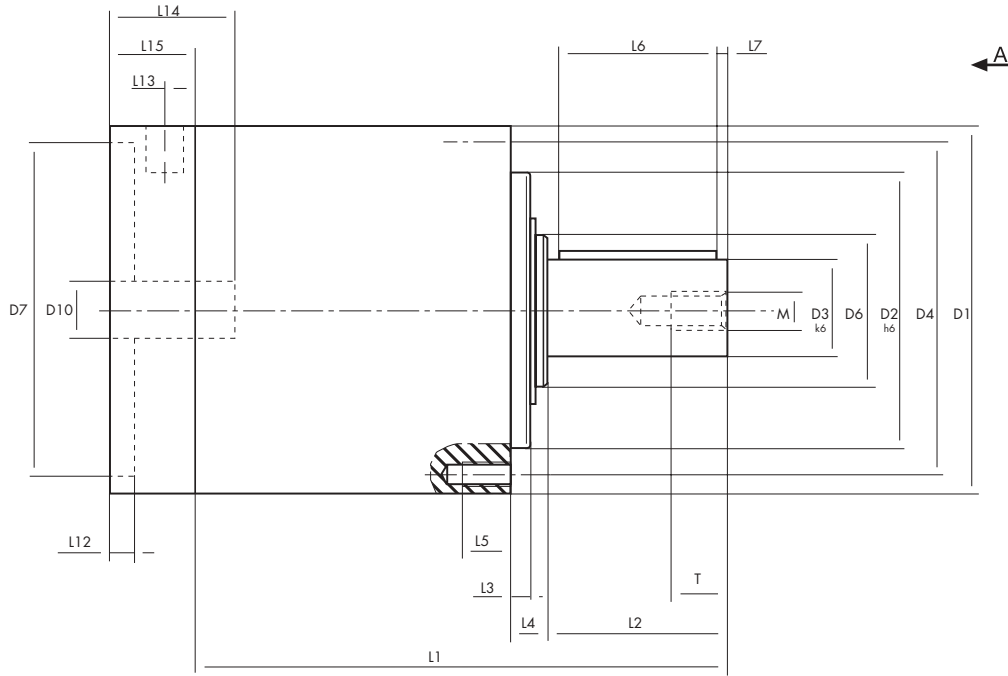

Gearbox dimensions [mm (in.)]

Size		LP 050	LP 070	LP 090	LP 120	LP 155
D1	Gear housing	50 (1,9685)	70 (2,7559)	90 (3,5433)	120 (4,7244)	155 (6,1023)
D2	Pilot diameter	h6 35 (1,3780)	h6 52 (2,0472)	h6 68 (2,6772)	h6 90 (3,5433)	h6 120 (4,7244)
D3	Output shaft diameter	k6 12 (0,4724)	k6 16 (0,6299)	k6 22 (0,8661)	k6 32 (1,2598)	k6 40 (1,5748)
D4	Output flange bolt circle	44 (1,7323)	62 (2,4409)	80 (3,1496)	108 (4,2520)	140 (5,5118)
D5	Mounting thread	4x90° M4	M5	M6	M8	M10
D6	Shaft shoulder diameter	17 (0,6693)	25 (0,9843)	40 (1,5748)	50 (1,9685)	65 (2,5590)
L1	Gear length	1-stage ¹⁾ 75 (2,9528)	104 (4,0945)	126 (4,9606)	172 (6,7716)	219,5 (8,6417)
		2-stage ²⁾ 91 (3,5827)	124 (4,8819)	152,5 (6,0039)	204,5 (8,0512)	250 (9,8425)
L2	Output shaft length	18 (0,7087)	28 (1,1024)	36 (1,4173)	58 (2,2835)	82 (3,2283)
L3	Pilot diameter width	4 (0,1575)	5 (0,1969)	5 (0,1969)	6 (0,2362)	8 (0,3150)
L4	Width	6,5 (0,2559)	8 (0,3150)	10 (0,3937)	12 (0,4724)	15 (0,5905)
L5	Mounting thread depth	8 (0,3150)	10 (0,3937)	12 (0,4724)	16 (0,6299)	20 (0,7874)
L6	Key length	14 (0,5512)	25 (0,9843)	32 (1,2598)	50 (1,9685)	70 (2,7559)
L7	Key location	2 (0,0787)	2 (0,0787)	2 (0,0787)	4 (0,1575)	6 (0,2362)
L8	Output shaft with key	13,5 (0,5315)	18 (0,7087)	24,5 (0,9646)	35 (1,3780)	43 (1,6929)
L9	Key width	h9 4 (0,1575)	h9 5 (0,1969)	h9 6 (0,2362)	h9 10 (0,3937)	h9 12 (0,4724)
M	Centering bore	M4	M5	M8	M12	M16
T	Depth of thread	8 (0,3150)	10 (0,3937)	13 (0,5118)	22 (0,8661)	32 (1,2598)

1) 1-stage ratios $i = 3^*, 5, 10$

2) 2-stage ratios $i = 15^*, 25, 30^*, 50, 100$

* Ratio $i = 3/15/30$ only for LP 70/90/120

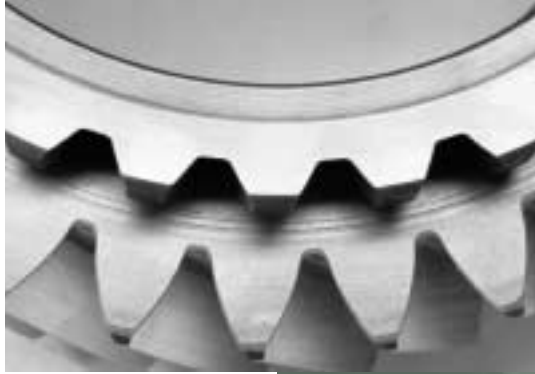

ZF PG Product Details



PG Gearboxes - Technical Data

Size :

Technical Data :

		i	PG 25	PG 100	PG 200	PG 500	PG 1200
Nominal output torque Also applicable for S1 operation	T_{2N} (Nm)	4	25	85	170	420	1020
		5	25	100	200	500	1200
		7	25	85	170	420	1020
		10	20	60	120	280	720
Emergency stop torque ¹⁾	T_{2Not} (Nm)	4	100	280	560	1260	3060
		5	100	330	660	1500	3600
		7	80	280	560	1260	3060
		10	80	200	400	840	2160
Max. acceleration torque ²⁾	T_{2B} (Nm)	4	50	170	340	840	2040
		5	50	200	400	1000	2400
		7	50	170	340	840	2040
		10	40	110	220	560	1440
Max. input speed	n_{1max} (rpm)	4	5000	5000	4000	3200	2500
		5	6300	6300	5000	4000	3200
		7	8000	8000	6300	5000	4000
		10	10000	10000	8000	6300	5000
Nominal input speed	n_{1N} (rpm)	4	3000	3000	2500	2000	1500
		5	4000	4000	3000	2500	2000
		7	5000	5000	4000	3000	2500
		10	6000	6000	5000	4000	3000
Backlash standard reduced ³⁾	(arcmin)		≤ 6	≤ 6	≤ 4	≤ 4	≤ 4
		≤ 3	≤ 3	≤ 2	≤ 2	≤ 2	
Torsional rigidity	C_t (Nm/ arcmin)		3.5	8.2	24	48	149
Moments of inertia	I_l (kg/cm ²)	4	0.16	0.55	2.00	6.75	24.5
		5	0.16	0.47	1.64	5.54	18.8
		7	0.15	0.41	1.36	4.59	14.5
		10	0.14	0.38	1.22	4.10	12.3
Max. axial force	F_A (N)		3200	4500	7000	10000	15000
Max. radial force ⁴⁾	F_R (N)		2700	3700	6700	9200	14000
Lifetime	L_h (h)		> 20000	> 20000	> 20000	> 20000	> 20000
Efficiency	η		≥ 97%	≥ 97%	≥ 97%	≥ 97%	≥ 97%
Weight	m (kg)		1.6	2.9	5.7	11.5	27
Operating noise at ($n_{an} = 3000$ rpm)	L_p (dB(A))		≤ 63	≤ 68	≤ 68	≤ 72	≤ 72

Lubrication

Lifetime lubrication, closed system

1) Max 1000 times in lifetime

Surface protection

Aluminium respectively steel, galvanically treated

2) De-rate for > 1000 stop/starts per hour

Installation position

Any, always changeable

3) Special option

Operating temperature

-10°C to + 90°C

4) Resultant force at centre of shaft

Direction of rotation

Same as input- and output speed

5) Speed 300rpm

Type of protection

IP 65

PG Gearbox - Dimensions

Dimensions (mm):		Size:				
		PG 25	PG 100	PG 200	PG 500	PG 1200
DR		M5	M8	M12	M16	M20
D ₁ (g6)		60	70	90	130	160
D ₂		20	28	40	45	60
D ₃ (k6)		16	22	32	40	55
D ₄		5.5	6.6	9	11	13
D ₅		68	85	120	165	215
D ₆ *(f7)	min.	6	14	19	24	32
	max.	14	24	32	38	48
L ₁ *		129,5	155,7	193,1	245,6	281
L ₂ (+ 0.5)		28	36	58	82	82
L ₃		20	20	30	30	30
L ₄		7.7	8	10	12,5	22
L ₆ *	min.	15	23	30	32	45
	max.	30	42	50	60	82
L ₇ *		3.5	4.5	5.5	5.3	8
L ₁₁		62	76	101	141	182
L ₁₂		2	2	2	3	3
L ₁₃ *		62	80	106	141	182
L ₁₄	min.	22	28	50	70	70
L ₁₅		3	4	4	5	5
L ₁₆		5	6	10	12	16
L ₁₇		18	24,5	35	43	59
L ₂₂ *		4.5	7,5	8.5	7.5	9
D7/D8/D9						

Motor connection dimensions for all common servomotors are available

*Dimensions depending on motor

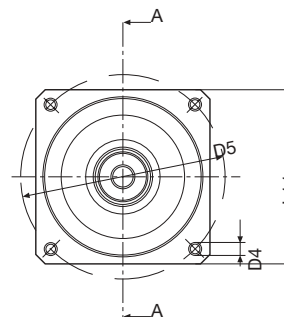
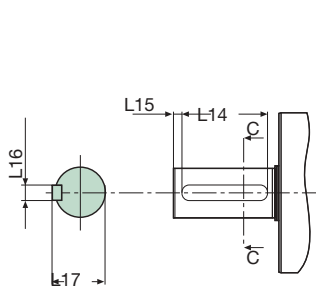
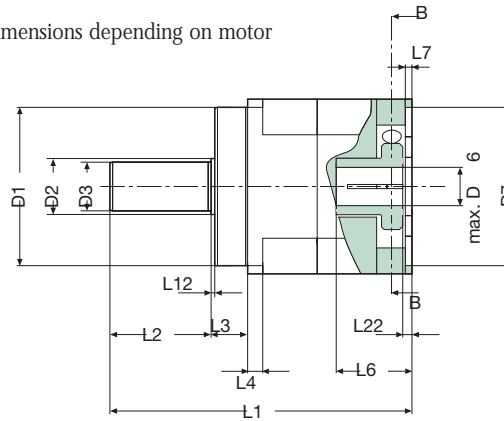
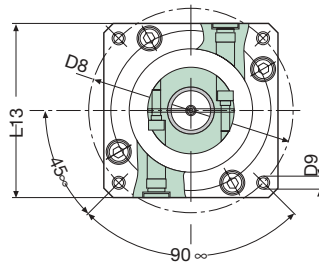

ZF WT Gearbox Product Details



WT Gearboxes - Technical Data

Right angle gearboxes

Technical data:		i	Size					
			WT 35	WT 70	WT 140	WT 260	WT 700	WT 1400
Nominal output torque	T_{2N} (Nm)	3-10	35	70	140	260	720	1440
		12-15	25	50	95	180	510	1020
Emergency stop torque ¹⁾	T_{2Not} (Nm)	3-10	70	140	280	520	1440	2880
		12-15	50	100	190	360	1020	2040
Max. acceleration torque	T_{2B} (Nm)	3-10	53	105	210	390	1080	2160
		12-15	38	75	143	270	765	1530
Max. input speed	n_{1max} (rpm)		8000	8000	7000	6000	5000	4500
Nominal input speed	n_{1n} (rpm)		6000	6000	5000	4000	3000	2500
Backlash	φ (arcmin)	stand. redu. ⁻¹	≤5	≤5	≤4	≤4	≤4	≤4
			≤3	≤3	≤2	≤2	≤2	≤2
Torsional rigidity	C_1 (Nm/arcmin)		3.5	7	17.5	39	103	210
Moments of inertia	I_1 (kg/cm ²)	3	0.43	1.10	2.5	6.7	24	72
		4	0.31	0.77	1.8	4.7	16	48
		5	0.24	0.63	1.4	3.8	13	37
		6	0.22	0.56	1.3	3.4	11	28
		8	0.18	0.47	1.1	2.8	8.6	24
		10	0.16	0.43	1.0	2.5	7.5	20
		12	0.15	0.41	0.93	2.4	6.9	18
		15	0.14	0.39	0.89	2.3	6.3	16
Max. axial force	F_A (N)		1650	2450	3600	5000	7500	11250
Max. radial force ²⁾	F_R (N)		3300	4900	7200	10000	15000	22500
Idling torque ($n_1 = 3000$ rpm)	T_{01} (Nm)	3	0.044	0.079	0.114	0.190	0.390	0.729
		10	0.024	0.043	0.065	0.101	0.189	0.311
Lifetime ³⁾	L_h (h)		>30000	>30000	>30000	>30000	>30000	>30000
Efficiency	η	3-10	≥96%	≥96%	≥96%	≥96%	≥96%	≥96%
		12-15	≥93%	≥93%	≥93%	≥93%	≥93%	≥93%
Weight	m (kg)		2,5	5	8,5	15	28	48
Operating noise at $n_{an} = 3000$ rpm	L_p (db(A))		≤66	≤66	≤68	≤68	≤70	≤72
Lubrication			Lifetime lubrication, closed system					
Surface protection			Prime coat RAL 9005 - dull black					
Installation position			Any					
Operating temperature			-10°C to 100°C					
Direction of rotation input to output			Same as motor					
Type of protection			IP 64					

WT Gearbox - Dimensions

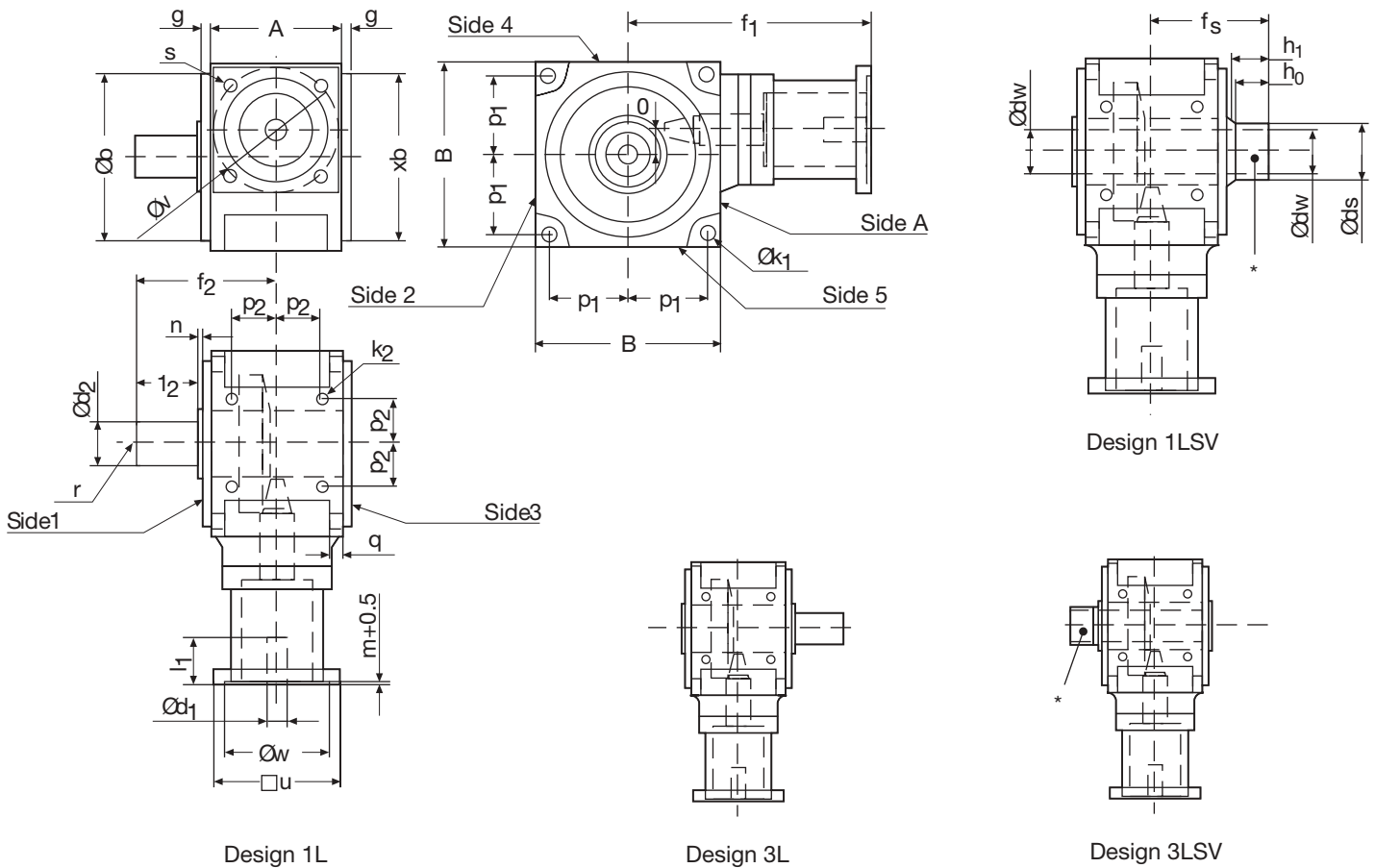

Right angle gearboxes

Dimensions (mm):

	WT 35	WT 70	WT 140	WT 260	WT 700	WT 1400
A	60	80	100	120	146	196
B	90	115	140	170	215	260
$\varnothing b(g6)$	89	105	125	150	195	245
g	13.5	8.5	8	8	10	10
o	9	14	18	23	32	42
p ₁	39	49	59	72	91	112
p ₂	22	27	33	40	52	70
$\varnothing k_1$	6.6	9	11	14	17.5	17.5
k ₂	M6	M8	M10	M12	M16	M16
q	8	10	11	13	15	17
$\varnothing d_2(k6)$	20	24	32	40	55	70
l ₂	35	40	50	60	90	110
f ₂	80	90	110	130	175	220
n	1.5	1.5	2	2	2	2
$\varnothing d_w(H7)$	20	25	30	40	55	70
$\varnothing d_s(f7)$	24	30	36	50	68	80
h ₀	20	22	26	29	32	34
h ₁	23	25	29	33	37	40
f _s	71.5	79.5	93	107	127	159
$\varnothing d_1$	9/11/14	11/14/19	14/19/24	19/24/32	24/32/38	32/38/48
l ₁	23/26/30	26/30/40	30/40/50	40/50/60	50/60/80	60/80/90
u x f ₁	55x130	75x168	90x191	115x220	140x260	190x335
	-	90x168	115x191	140x220	190x265	260x345
	75x140	90x180	115x201	140x235	190x280	-
$\varnothing v$						
$\varnothing w$						
s						
m						

According to DIN 332 Form D

$\varnothing v$, $\varnothing w$, s, m } PCD, spigot dia thread and centering depth according to respective motor data sheets

Fanblown Motor Description

Control Techniques easy to fit fan cowlings provide outstanding performance improvements with power densities not hitherto possible achieved in a small volume. This powerful means of forced convection enables a higher rms torque output for the same motor winding temperature. Cool air from the rear of the motor is channelled through the Unimotor's specially designed fins bringing a substantial increase to rated and stall torque of the motor. Peak torque remains unaffected.

The fan cowlings can be added to new or existing installations, wherever additional power is required.

- Easy to fit - slide on and clamp
 - Peak torque is unimpeded
 - High power density for installations with limited space
 - Encoder motors can run at $\Delta 125^{\circ}\text{C}$ rating
- Optimize power where thermal path is restricted, such as gearmotor applications

Specification

- Fan Voltage - 230V ; 0.1A ; 50-60Hz
 - Air Direction - from rear to front
 - Fan IP Rating - IP20
 - Motor/Fan Combined Performance - De-rate above 40°C
 - Cooling Air - fluff and fibre free.
- If filter is to be used, performance must be de-rated.

Note 1: Not applicable for UL recognised motors.

Note 2: Not suitable for standard SL motors, because stored SL performance data remains unchanged in the motor.



Fanblown Motor Performance

Motor Type	Stall Torque (Nm)	Rated Torque (Nm) for motor speeds (rpm)			Motor Type	
		2000	3000	4000	Unbraked	Braked
	All Speeds				COWLING ORDER REF	
75UMA	1.4	1.4	1.4	1.3	75FB01	75FB02
75UMB	2.8	2.8	2.8	2.5	75FB02	75FB03
75UMC	4.3	4.3	4.2	3.8	75FB03	75FB04
75UMD	6.1	5.9	5.7	5.2	75FB04	75FB05
95UMA	2.9	2.7	2.6	2.4	95FB01	95FB02
95UMB	5.7	5.3	5.2	4.3	95FB02	95FB03
95UMC	8.4	8.1	8.0	6.7	95FB03	95FB04
95UMD	11.5	11.0	10.9	9.2	95FB04	95FB05
95UME	14.6	13.9	13.8	12.0	95FB05	95FB06
115UMA	4.8	4.4	4.1	3.8	115FB01	115FB02
115UMB	9.2	8.5	8.2	7.6	115FB02	115FB03
115UMC	14.0	13.2	12.8	11.2	115FB03	115FB04
115UMD	19.3	18.0	17.8	14.7	115FB04	115FB05
115UME	25.7	23.3	22.9	18.9	115FB05	115FB06
142UMA	8.5	8.0	7.5	5.7	142FB01	142FB03
142UMB	15.3	14.9	13.6	11.6	142FB02	142FB04
142UMC	22.5	22.4	20.0	16.7	142FB03	142FB05
142UMD	30.2	30.0	27.4	22.3	142FB04	142FB06
142UME	37.0*	36.0	33.8	28.0	142FB05	142FB07
190UMA	28.8	26.7	25.9	~	190FB01	190FB02
190UMB	55.7	54.2	50.3	~	190FB02	190FB03
190UMC	84.1	73.2	57.8	~	190FB03	190FB04
190UMD	107.6	83.8	65.9	~	190FB04	190FB05

Notes: Torque performances shown are applicable for motors with either encoder or resolver, temperatures taken to $\Delta T = 125^{\circ}\text{C}$.

The increase in torque output will require a higher drive current. This will require adequate power cable for the current required.

* 142UME 400 : maximum continuous stall torque is limited to 28Nm due to connector current limitation.

WARNING: Peak torque values remain as quoted for non-fan-blown performance (section 3).

Fanblown Motor 75-115 Dimensions

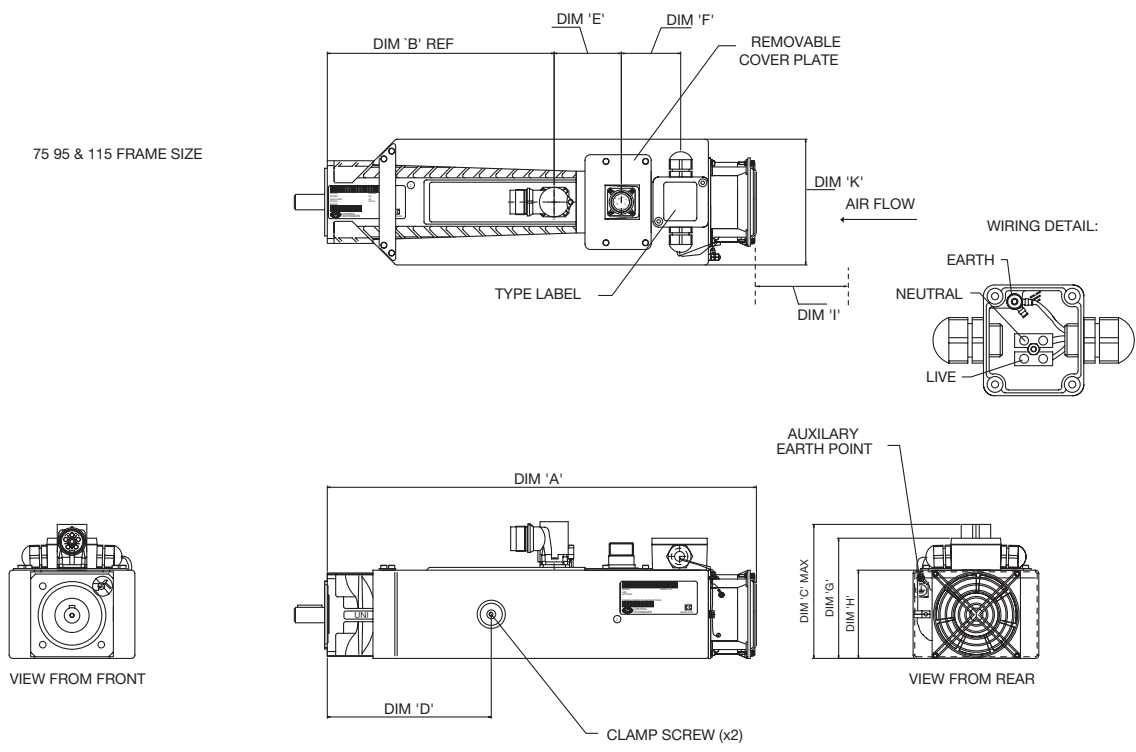

Frame Size		75				95				115					
Dimension/Length suffix		A	B	C	D	A	B	C	D	E	A	B	C	D	E
A	Length Overall (Unbraked)	296	326	356	386	316	346	376	406	436	309	339	369	399	429
A	Length Overall (Braked)	326	356	386	416	346	376	406	436	466	339	369	399	429	459
B	Front Flange to Power C/L (Unbraked)	116	146	176	206	125	155	185	215	245	142	172	202	232	262
B	Front Flange to Power C/L (Braked)	146	175	206	236	155	185	215	245	275	172	202	232	262	292
C	Overall Height	135 max.				157 max				177 max.					
D	Clamp Screw to Front Flange (Unbraked)	97	112	127	142	100	115	130	145	160	128	143	158	173	188
D	Clam Screw to Front Flange (Braked)	112	127	142	157	115	130	145	160	175	143	158	173	188	203
E	Power C/L to Feedback Connector C/L	61.0				62.6				66.0					
F	Connector Box C/L to Fan Terminal Box C/L	53.8				53.8				44.4					
G	Height to Top of Fan Terminal Box	110.5				129.0				150.0					
H	Height to Top of Fan Casing	80.5				100.0				120.0					
I	Air Intake Clearance	40.0				40.0				40.0					
K	Width	115.0				135.0				159.0					

10

Fanblown Motor 142-190 Outline

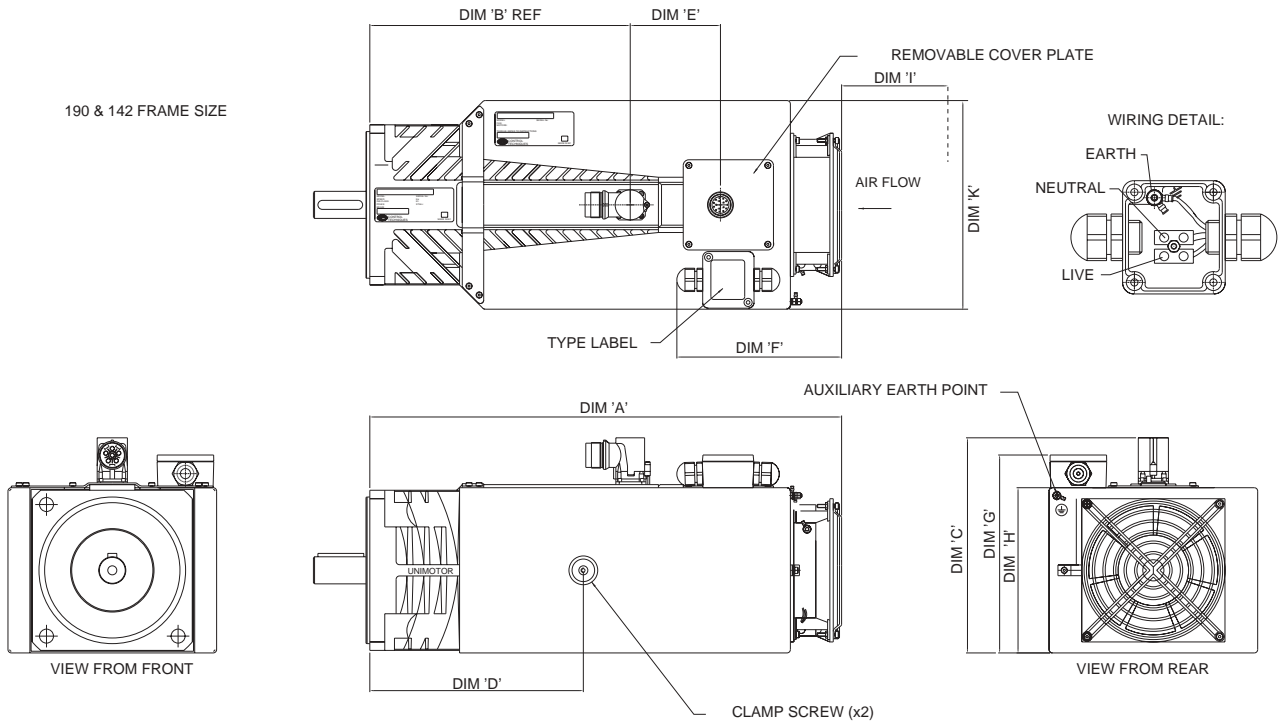

Fanblown Motor 142-190 Dimensions

Frame Size		142					190			
Dimension/Length suffix		A	B	C	D	E	A	B	C	D
A	Length Overall (Unbraked)	303	333	363	393	423	369	423	477	531
A	Length Overall (Braked)	363	393	423	153	483	423	477	531	584
B	Front Flange to Power C/L (Unbraked)	111	141	171	201	231	69	123	177	231
B	Front Flange to Power C/L (Braked)	171	201	231	261	291	123	177	231	285
C	Overall Height	204 max.					262 max.			
D	Clamp Screw to Front Flange (Unbraked)	151	166	181	196	211	170	197	224	251
D	Clam Screw to Front Flange (Braked)	181	196	211	226	241	197	224	251	270
E	Power C/L to Feedback Connector C/L	80.0					173.0			
F	Connector Box C/L to Fan Terminal Box C/L	147.0					167.0			
G	Height to Top of Fan Terminal Box	176.0					225.0			
H	Height to Top of Fan Casing	147.0					196.0			
I	Air Intake Clearance	40.0					60.0			
K	Width	187.0					240.0			

Characteristics Motor Power and Signal Cables

Cables are an important part of a servo system installation. Not only must the noise immunity and integrity of the cabling and connectors be correct, but also SAFETY and EMC regulations must be complied with to ensure successful, reliable and fail safe operation. One of the most frequent problems experienced by motion systems engineers is incorrect connections of the motor to the drive.

CT Dynamics ready -made cables mean system installers can avoid the intricate, time consuming assembly normally associated with connecting servo systems. Installation and set-up time are greatly reduced - there is no fiddling with wire connections and crimp tools, and no fault finding. The cables are made to order in lengths from 1m to 50m/100m.

DS To Conversion Cables

DS to DM power/power-brake and signal conversion cables are available, to a maximum length of 400mm. These cables will allow the engineer to convert from an existing DS motor application, with system cabling, to a DM Unimotor.

Cable Range

Cable range for motor-drive combinations:

- UM & Unidrive / Unidrive SP
- DM & Digit'Ax
- DS & Digit'Ax
- SL & M'Ax or MultiAx
- EZ & Unidrive / Unidrive SP low voltage
- EZ & Epsilon or EN
- MM to Mini'Ax
- DS to DM conversion cables

Power cable variants:

- Phase conductors 1.5mm² (16A) to 16mm² (70A)
- With and without brake wire pairs
- Motor end Connector
- Motor end Ferrules for Hybrid box
- Drive end is tailored to suit the drive and can be Ferrules or Ring terminals



PUR Cable Features

- Dynamic performance
- PUR outer sheath for oil resistance and dynamic performance
- Complies with DESINA coding - Orange for power, Green for signal
- Power cable and plugs UL recognised
- Optimum noise immunity
- UM Encoder cable has low volt drop for long cable lengths and separately screened thermistor wires.
- Brake wires are separately shielded within the power cable
- No need for crimp and insertion / removal tools
- Production build gives quality and price benefits
- Production build gives quality and price benefits
- Braided screen for greater flexibility and wear
- Power cables with and without brake wires
- Cable assembly type identification label

Cable Types for UM; EZ and SL motors

Cables with Desina colours (Power = Orange, Signal = Green)

Power

Phase & conductor size (current rating Cenlec EN60204.1)	Unimotor size Power plug size	Current rating	Overall cable diameter(mm) No brake	Overall cable diameter(mm) braked
G - 1.5mm ² (16A)	75-142 size 1	30A sockets	10.2	12.0
A - 2.5mm ² (22A)	75-142 size 1	30A sockets	11.8	12.8
B - 4.0mm ² (30A)	75-142 size 1 190 size 1.5	30A sockets 53A sockets	14.4	14.4
C - 6.0mm ² (39A)	190 size 1.5	70A sockets	17.4	17.4
D - 10.0mm ² (53A)	190 size 1.5	70A sockets	20.4	20.4
E - 16.0mm ² (70A)	190 size 1.5	70A socket	23.4	23.4
F - 1mm ² (Unscreened)	DS Brake			

Note minimum bend radius = 10x dia

Signal

Drive Type	Motor Type	Cable Type
Unidrive / Unidrive SP	UM/DM	Encoder SI;SinCos SS;Resolver SR
Digit'Ax	DS/DM	Resolver SR
M'Ax / Multi'Ax	SL	Speed loop Module SL
Epsilon / EN / Unidrive LV	EZ	Encoder SI;Resolver SR
Mini'Ax	MM	Encoder SI

Signal – basic cable types

Cable type	Cable code	Overall cable diameter(mm)
Encoder	SIBA	10.9
Resolver / Sincos	SRBA/SSBA	9.6
SLM	SLBA	6.2
Low cost Encoder	SIBL	8.5

Selecting Power Cables

Cable type - PS for motor without brakes, PB for motors with brake.

Jacket - B is for a PUR sheath and is the standard selection. A is for a PVC sheath to be used on the DS brake cable only.

Conductor Size - Select the conductor size according to the motors STALL CURRENT.

Include forced cooling performance if applicable.

Cables of 6mm² and above will be fitted with ring terminals only.

Ratings are for individual cables (not lashed together) in free air temperature up to 40°C - make allowances as appropriate.

Connection detail drive end - Select the correct drive end connection for the drive in use.

Connection detail motor end - Select the correct motor end connection for the motor in use.

Length - Numbers represent the required cable length in metres. Conversion cables will be limited to 0.4m only and the length is not required in the order code.

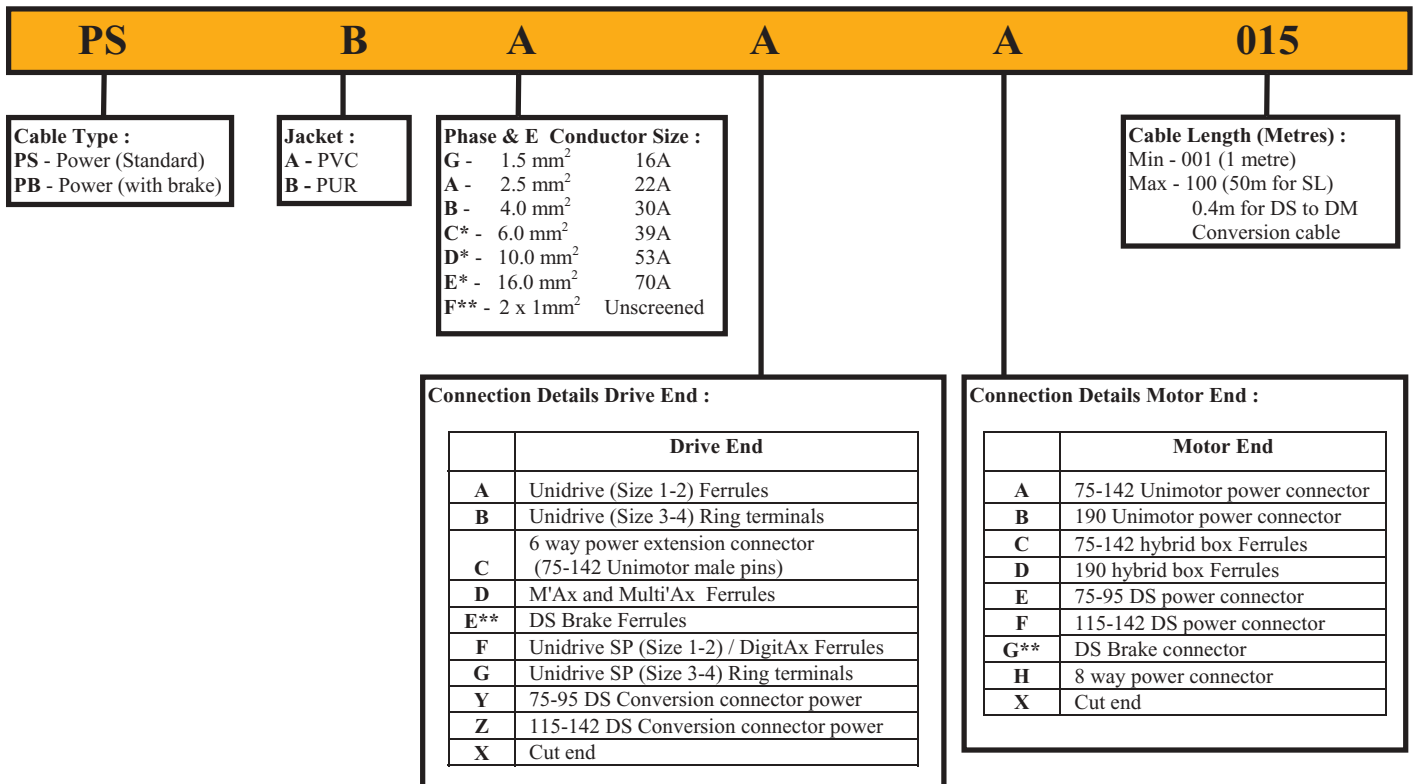

* Ring terminals for Drive studs only
** PVC only available on DS brake cables

Selecting Signal cables

Cable type - Choose the cable type to match the feedback device.

Jacket - B is for a PUR sheath and is the standard selection.

Special options - A is for standard cable. L is for the low cost 8.5mm incremental cable.

Connection detail drive end - Select the correct drive end connection for the drive in use.

Connection detail motor end - Select the correct motor end connection for the motor feedback device in use.

Length - Numbers represent the required cable length in metres. Conversion cables will be limited to 0.4m only and the length is not required in the order code.

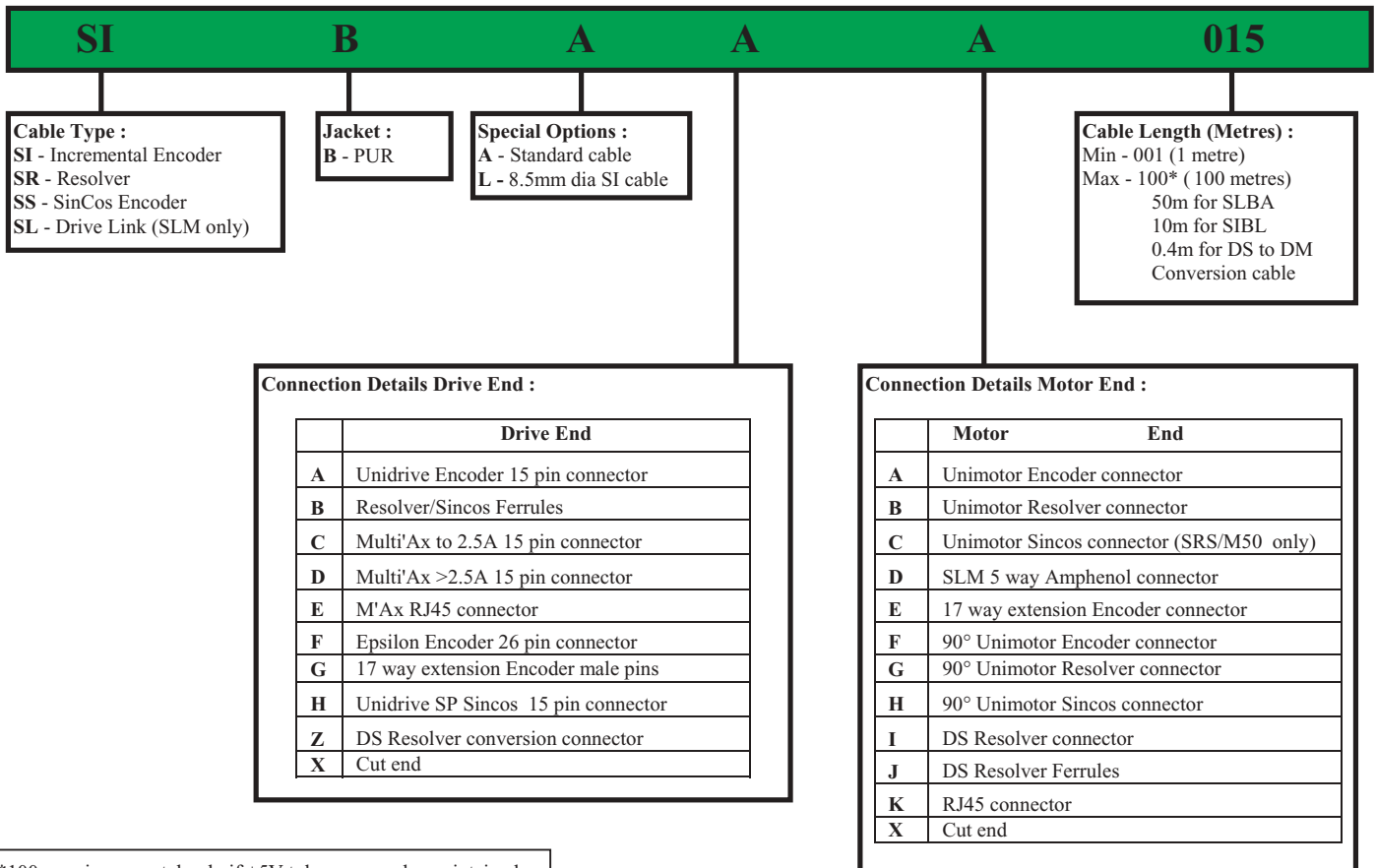

Power Cable with brake PBBxAxxx

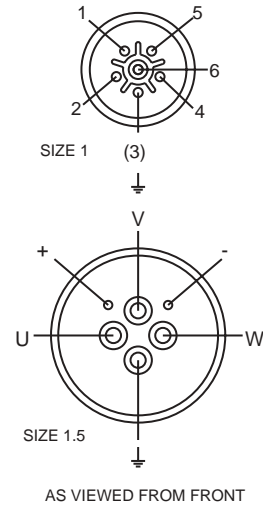
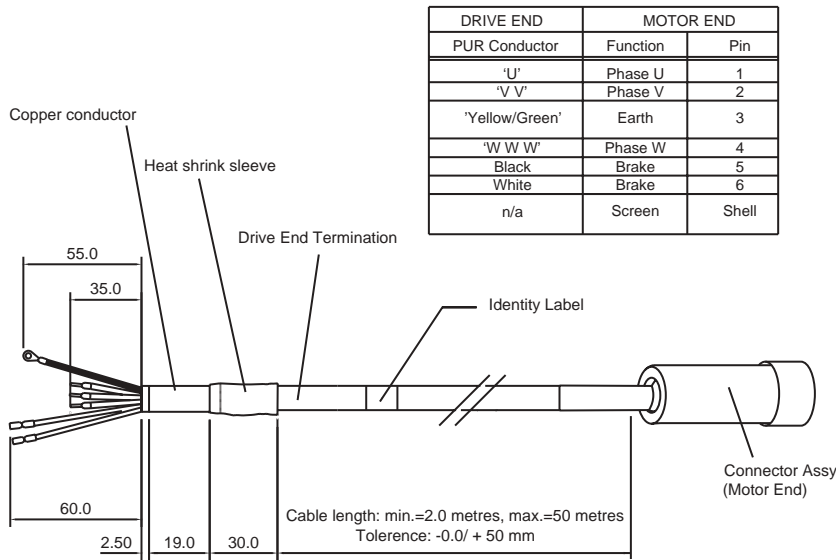

Power Cable without brake PSBxABxxx

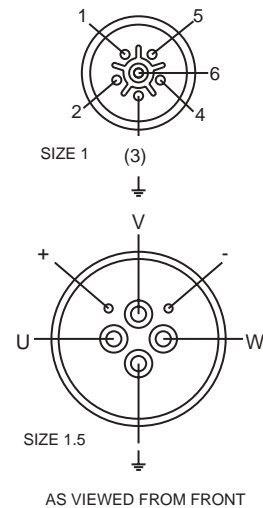
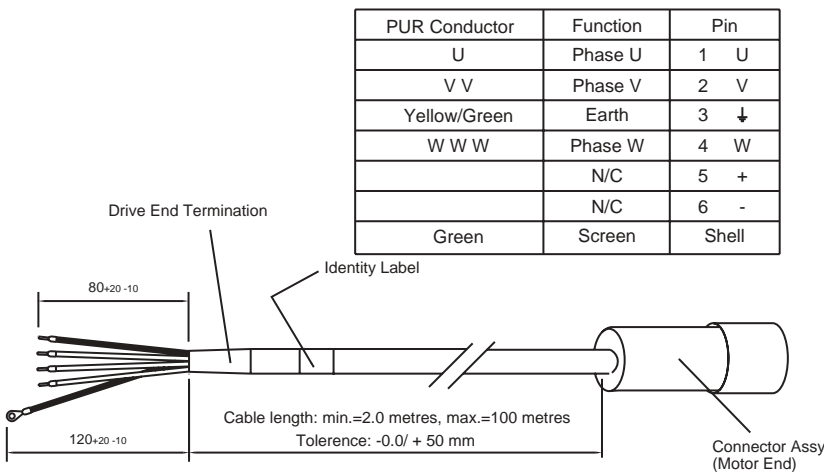

11

Signal cable Encoder SIBxAAXxx

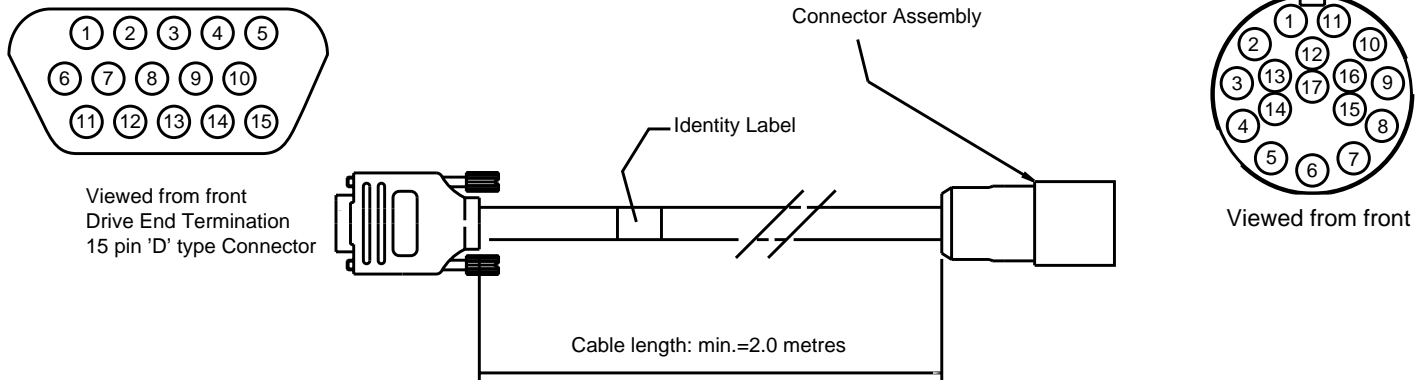

Incremental Cable:-
 SIBAxxxx, dia 10.9 length 100m max
 SIBLxxxx, dia 8.5 length 10m max

15 Way drive connections			17 Way Motor Encoder Plug
Pin	Colour	Function	Pin
Body	White	Thermistor 0V	1
15	Brown	Thermistor Signal	2
-	-	n/c	3
7	Green	S1	4
8	Yellow	S1 Inverse	5
9	Grey	S2	6
10	Pink	S2 Inverse	7
11	Black	S3	8
12	Purple	S3 Inverse	9
1	Grey/Pink Band	Channel A	10
5	White/Green Band	Index	11
6	Brown/Green Band	Index Inverse	12
2	Red/Blue Band	Channel A Inverse	13
3	Red(0.38mm ²)	Channel B	14
4	Blue(0.38mm ²)	Channel B Inverse	15
13	Red(1.0mm ²)	+ 5V	16
14	-	-	17
Body	Screen	Screen	Body

Signal cable Sincos SSBxBCxxx

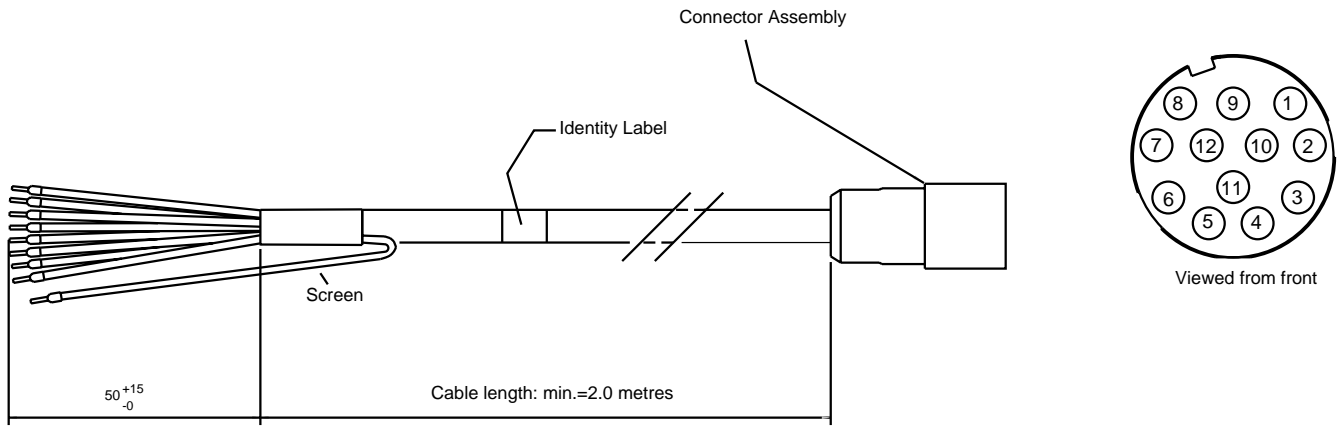

Signal cable Sincos SSBxAHxxx

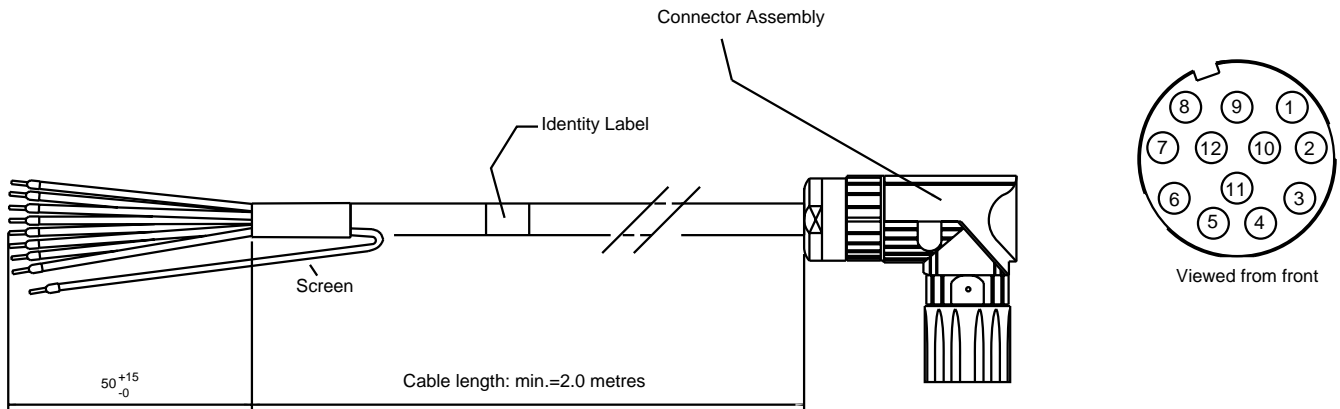

Signal cable Resolver SRBxBBxxx

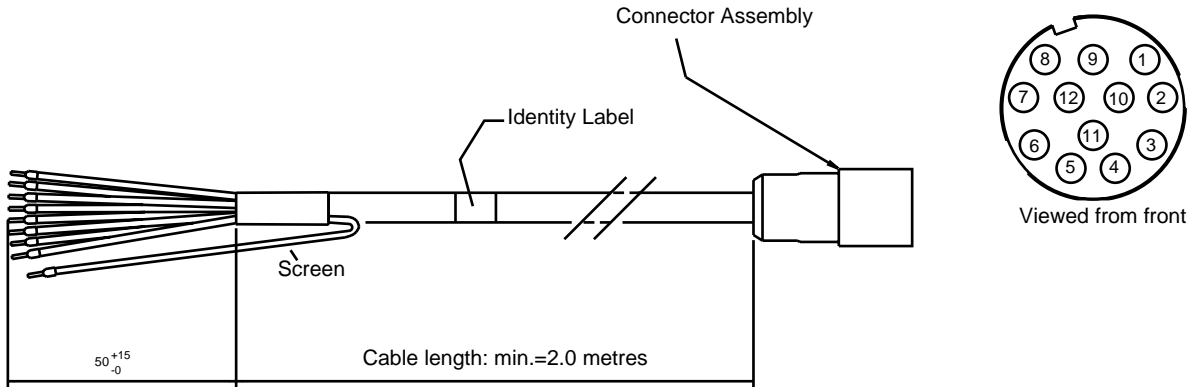

12 Way Motor Resolver Plug			12 Way Motor SinCos Plug	
Pin	Colour	Function	Colour	Function
1	Red(0.38mm ²)	Excitation high	Red(0.38mm ²)	REF Cos
2	Orange	Excitation low	Blue(0.38mm ²)	+ Daten
3	Blue(0.38mm ²)	Cos high	Violet	-Daten
4	Violet	Cos low	Orange	+ Cos
5	Brown	Sin high	Brown	+ Sin
6	Black	Sin low	Black	REF Sin
7	Yellow	Thermistor	Yellow	Thermistor
8	Green	Thermistor	Green	Thermistor
9	-		Screen	Screen
10	-		Blue(0.5mm ²)	0 Volts
11	-		-	-
12	-		Red(0.5mm ²)	+ Volts
Body	Screen	Screen	Screen	Screen

Signal Cable SLM SLBAEDxxx (M'Ax)

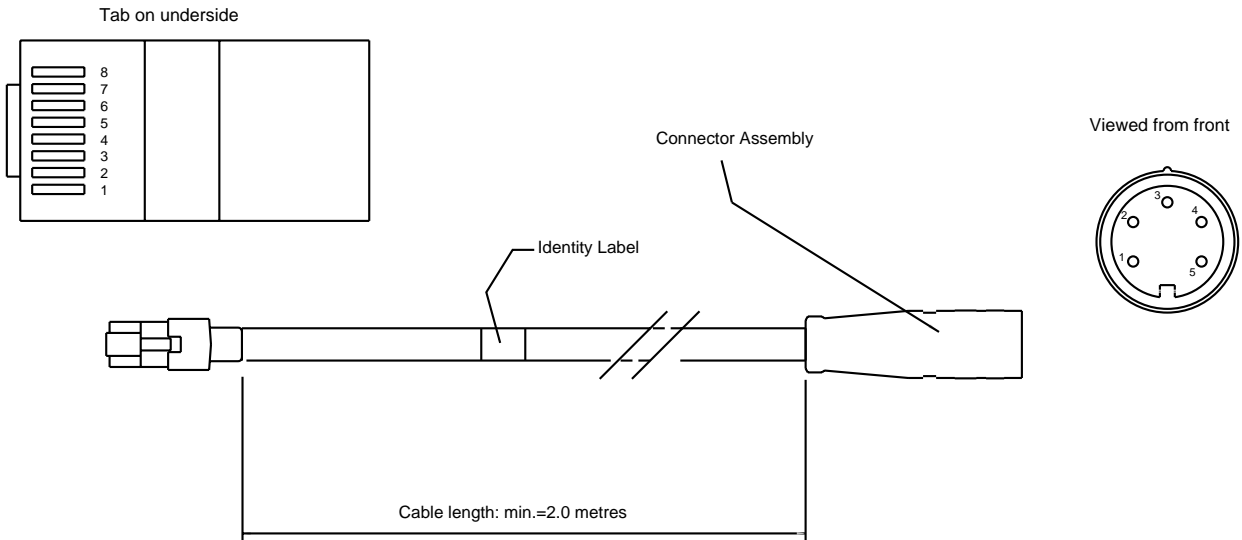

Signal Cable SLM SLBACDxxx (Multi Ax to 2.5A) SLBADDxxx (Multi Ax > 2.5A)

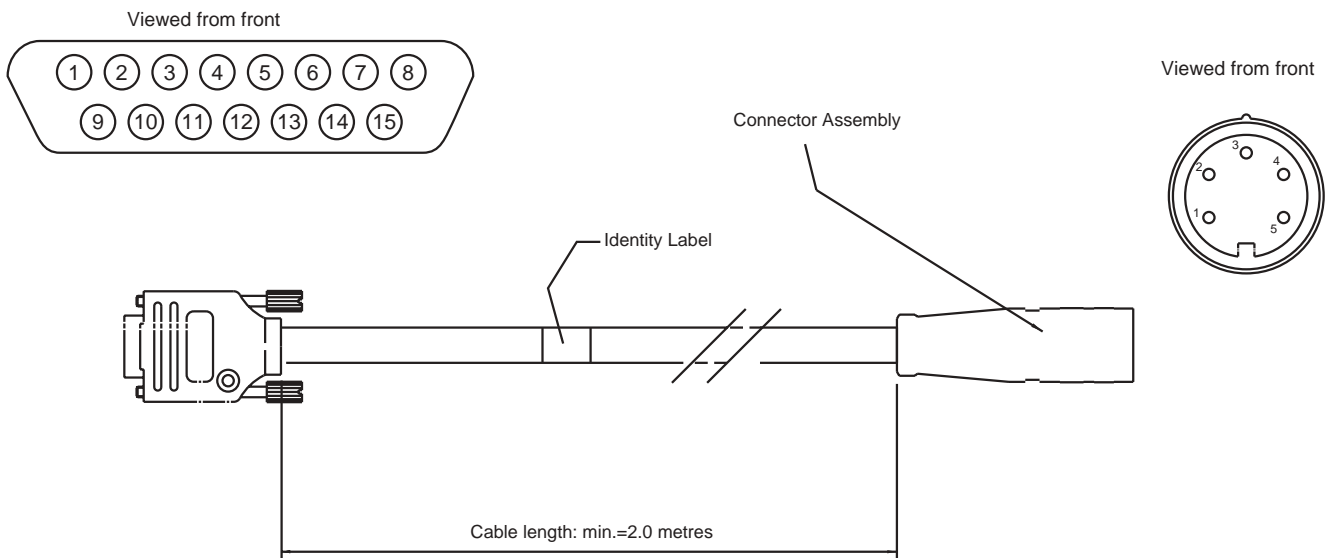

D type	Amphenol	RJ45	Function	Colour
14	1	2	Comm	Brown
13	5	1	Comm	White
9	3	5	+ 24V	Yellow
10	2	6	0V	Green
15	4 + Body	Body	Screen	Screen
7 + 6	Connected together with 26 AWG tinned copper wire on > 2.5A option only			

11

Selecting Connector Kits

CT Dynamics can supply a full range of connectors for the UM/DM/EZ and SL motors. The tables below show the connector kits and spare sockets that are available.

Single Connector Type	CTD Part No	Spare Sockets
75-142 Power (30A)	IM/0039/KI	IM/0047/KI
190 Power (4mm ² cable : 53A)	IM/0053/KI	IM/0056/KI
190 Power (> 6mm ² cable : 70A)	IM/0054/KI	IM/0057/KI
Encoder	IM/0023/KI	IM/0049/KI
Resolver/Sincos	IM/0022/KI	IM/0049/KI
SLM	IM/0055/KI	-
Resolver/Sincos 90°	IM/0033KI/01	IM/0049/KI
Encoder 90°	IM/0033/KI/02	IM/0049/KI
Brake	-	IM/0048/KI

Power/Signal Type	CTD Part No
75-142 Power + Encoder	IM/0012/KI
75-142 Power + Resolver	IM/0011/KI
75-142 Power + SLM	IM/0024/KI

Selecting the Correct Motor

A reliable servo system will depend upon initial system design and correct selection of motor, feedback, gearbox and drive. To ensure success pay careful attention to the following points:

- Speed, acceleration and inertia
- Peak and rms torque
- Motor feedback type
- Gear ratios
- Drive system operational mode
- Thermal effects
- Environmental conditions
- Size
- Cost of motor-drive combination

It is necessary to estimate the root mean square (rms) torque value of the load. Where the motor has varying duty cycles it may be necessary to consider the worst case only. Never exceed maximum peak torque ratings. Calculate the RMS load torque at the motor and ensure that this is less than the motor rated torque. Allow an additional 15% on the load for inefficiencies and tolerances.

Choose a suitable motor within the size limitations of the installation. The frame size and motor speed may be selected using the performance data. Look for the rated torque at the appropriate temperature.

Control Techniques Sizing Software (CTSS) can simulate most systems and select suitable motors. This is highly recommended and is available as a FREE download from www.drivesportal.com

If you have any questions, please discuss your application with us. This section explains some of the points in more detail.

Use the Checklist of Operating Details to make notes about the application.

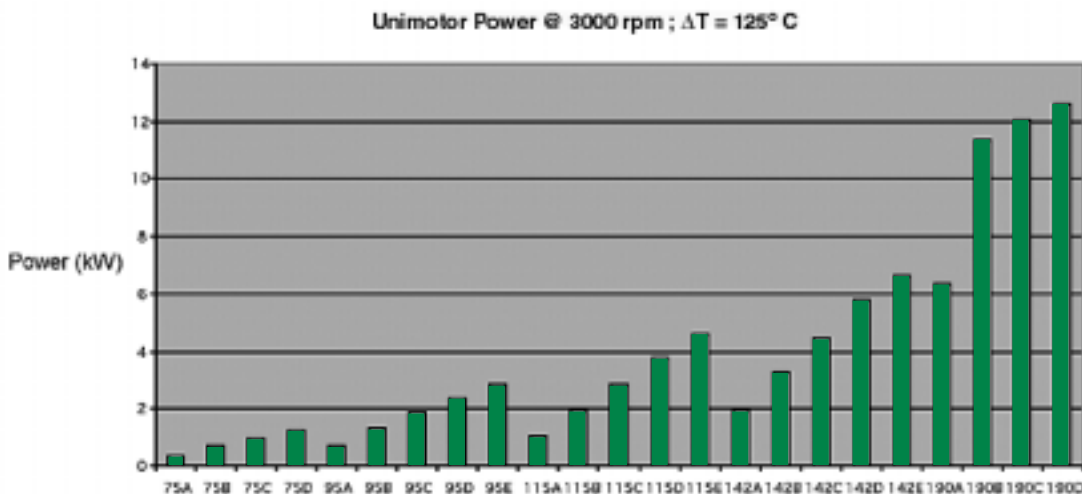

Checklist of Operating Details

Complete this checklist to help select which Unimotor best suits your application requirements.

Torque Speed (Use CT sizing software to help choose the correct motor)

- What motor operating speed do you require (rpm)? (tick one)
 - 2000
 - 3000 (Standard)
 - 4000
 - 6000
 - Other (non standard) speed

- What is the rms torque? (See section on Calculating Load Torque). Decide on switching frequencies for drive, and de-rate motor or drive accordingly.

- If the ambient temperature is greater than 40° C, apply a derating factor. If the motor is mounted to a hot interface; or interfaced with low thermal mass; or high thermal resistance; apply a derating factor. Torque ratings of motors are stated in controlled conditions mounted on a reference front plate. Details of this are found in the performance data section.

- Inertia mismatch (ratio of motor inertia to load inertia reflected to motor shaft) can be as high as 3:1 for acceleration rates of 1000 rad/s² for a typical system. Larger mismatch or acceleration can be tolerated with a rigid mechanical system and high resolution feedback.

- Do you require a parking brake?
 - Yes (option) No (standard)

Motor Mounting

- Does the motor fit the machine? Make allowances for cables and connections.

- Do you require output key or plain shaft?
 - Output key (standard) Plain shaft (option)

NB. When gearbox is fitted, this choice applies to the gearbox o/p shaft, as supplied by CTD.

Feedback

- Do you want an encoder or resolver? See section Feedback Devices.
 - Incremental encoder (standard)
 - Resolver (option)
 - Sin/cos single-turn (option)
 - Sin/cos multi-turn (option)

- Do you require SLM feedback for M'Ax Drive?

Electrical Connections

- Hybrid connection type has limited availability. Choose connector if possible.
 - Connector, rotatable (standard) Hybrid (option)

Other options

- Do you require a gearbox?
 - Yes (option) No (standard)

- Many other custom special motors are made by CTD. If you require something not in this catalogue please ask. (See www.controltechniques.com or ctdynamics.com for Technical Application Sheet or Enquiry Sheet).

12

Points To Consider

Torque and Temperature

- The maximum allowable temperature of the motor windings or feedback device should not be exceeded. The windings have a certain mass and hence a long thermal time-constant ranging from 1.5 minutes to over an hour. Dependent upon motor temperature the motor can be overdriven for shorter periods without exceeding the temperature limitations. Set motor winding thermal time constant into drive parameter. (Auto for SLM & M'Ax). The parameter is used for thermal shock (I^2T) calculations within the drive.
- The motor winding thermal time constant should be large in comparison with the medium term periods of high rms torque.
- Ensure that the drive's features, such as switching frequencies, waveforms, peak and continuous currents, are suitable for the application. Low switching frequencies of the drive will require motor derating.
- Torque estimates should include friction and acceleration (and hence inertia) calculations.
- Consider the motor cooling effects; for example, is the conductive thermal path adequate? Is the motor mounted on a hot gearbox?
- Ensure that the motor and drive can meet the short term peak torque requirements.

Braking

- If a load requires dynamic braking by the motor under servo control, energy is transferred back into the system. Then a pump-up effect occurs at the drive system that raises the DC bus link voltage. To prevent the link volts from rising too far, and to protect the drive devices, brake dump resistor(s) may need to be fitted to the drive. Please refer to the drive system manual.
- The installation may also require static parking brakes. This is an option available on all Unimotor types.

Inertia

- Ensure that the motor has correct inertia matching to suit the acceleration requirements. Consider inertia load matching especially for acceleration levels above $1,000 \text{ rad/s}^2$. Motors with larger frame diameters have higher inertia. Higher inertia rotor options are available.

Vibration

- Think about any other environmental factors that may be important, such as vibration. See IEC60068 part 2.

Cables

- Think about the cable lengths required for the installation, and the suitability of the cables, drive and feedback signals involved. You should ensure compliance with both SAFETY and EMC regulations.
- Ensure motor is mounted firmly and properly earthed. Screen all cables to reduce system noise and EMC.

Feedback

- Recheck your choice of feedback device and the compatibility of feedback.
- To achieve a good system it is necessary to ensure stiff connections and couplings to all rotating parts, so that a high servo bandwidth can be achieved. This will improve stability and enable higher servo gains to be set, ensuring higher accuracy and positional repeatability.
- High resolution feedback will increase stability and allow greater acceleration or inertia mismatch

Bearing loads

- Check the radial and axial loading are within the limits of the motor. (See bearing life calculations at the end of this section.)

Calculating Load Torque

In any application, the load consists of various torque loads plus acceleration and deceleration of inertia:

Constant Torque Periods.

Periods where a torque is maintained at constant or near constant motor speeds.

Acceleration & Deceleration

Torque is required to achieve acceleration and deceleration. Acceleration times of less than one second can often be achieved using peak torque capability of the drive and motor. See the graph below.

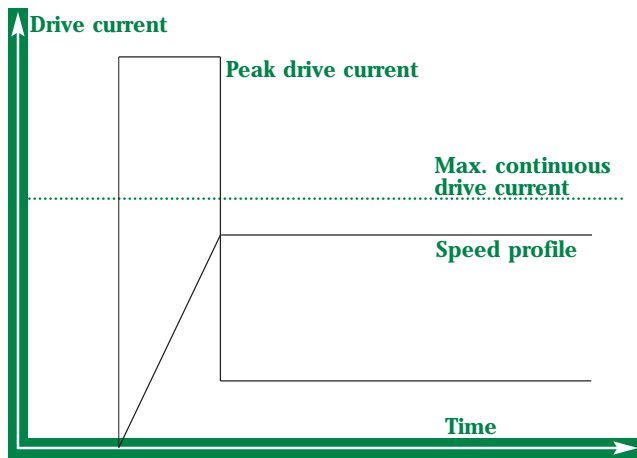

Note: Peak drive current may be set by drive control to the motor's continuous current rating. If this is required, check that it is within the drive's capability. Medium periods of up to 200% over current are often acceptable for the motor, provided that the heating effects are not too rapid and that the motor thermal time constant is long in comparison.

Inertial loads on a common shaft may be added together. Inertial loads may be reflected from the output of a reduction gearbox to the motor by dividing the output inertia by the square of the ratio.

Total inertia = reflected inertial load at motor + motor inertia

Torque T required to accelerate/decelerate inertia J is given by:
 $T = J\alpha Nm$

where α = acceleration in rad/s²
 (1 rev = 2π rads)
 J = inertia in kgm²

RMS torque for a repetitive duty cycle:

1. Draw a graph of torque (T) against time for one complete repetitive cycle of events (or choose the worst case of various events.) Make the T axis vertical. On the same graph, draw the speed profile against time for one cycle.

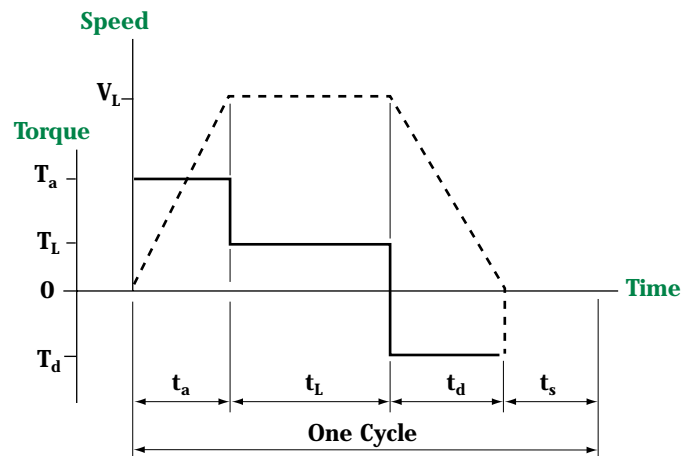

2. From the above speed-torque diagram calculate the rms torque using the formula:

$$T_{rms} = \sqrt{\frac{T_a^2 \times t_a + T_L^2 \times t_L + T_d^2 \times t_d}{t_a + t_L + t_d + t_s}}$$

where T_a = Acceleration Torque (Nm)
 T_L = Load Torque (Nm)
 T_d = Deceleration Torque (Nm)
 t_a = Acceleration Time (sec)
 t_L = On load running time (sec)
 t_d = Deceleration time (sec)
 t_s = Stop time (sec)
 V_L = Full load speed (rpm)

12

Inertia formula and accelerating or decelerating torque:

The moment of inertia J of a solid cylinder about an axis is:

$$J = \frac{Mr^2}{2}$$

where M = mass in kg and
 r = radius in m

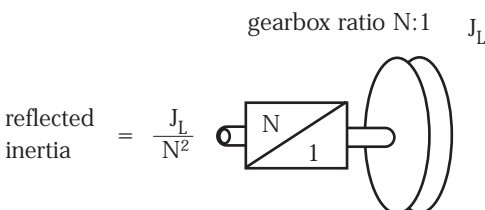

Example

In an application where the torque-speed profile is as above with $T_a = 20 \text{ Nm}$, $T_L = 5 \text{ Nm}$, $T_d = -10 \text{ Nm}$, $t_a = 20 \text{ ms}$, $t_L = 5 \text{ s}$, $t_d = 30 \text{ ms}$, $t_s = 3 \text{ s}$ and $V_L = 3000 \text{ rpm}$. Calculate the RMS torque for this application.

$$T_{rms} = \sqrt{\frac{20^2 \times 0.02 + 5^2 \times 5 + 10^2 \times 0.03}{0.02 + 5 + 0.03 + 3}} = \sqrt{\frac{136}{8.05}}$$

$$T_{rms} = 4.11 \text{ Nm}$$

15% tolerance required, hence RMS torque for this application = 4.73Nm

Understanding Motor Heating Effects

During operation, the motor is subjected to heating effects from several sources. Some of these are obvious; others obscure. Whilst the motor specification allows for most of these heating effects, others depend on the application. This section examines some of the causes of motor heating.

Motor copper loss

Motor copper loss is a product of RMS motor current squared and the resistance of the motor windings. It includes ripple current, determined by the switching frequency of the drive and the inductance of the motor. The inductance of the Unimotor windings is generally relatively low, so that the maximum drive frequencies should be selected commensurate with drive heating losses. Data in this manual is for switching frequencies as stated in the performance data section. If lower frequencies are used, motor performance is reduced.

Motor copper loss also includes losses arising from waveform distortions of either the drive or motor or both. The motor's back EMF waveform is sinusoidal and of low harmonic distortion. If lower frequencies are used, the drive current has higher harmonic distortion, and hence the motor performance is reduced.

Motor current depends on the torque demanded by the load at any instant. This is normally given by the motor torque constant (Kt) in Nm/A. Although regarded as a constant, Kt decreases slightly when the motor is at maximum temperature. Note that motor ripple current exists with no torque and even when the motor is not rotating.

Smaller motors may use trapezoidal DC drives to power the sinusoidal brushless motors. Note: that for these Kt is quoted as Nm/A (dc) and currents are A (dc).

The Ke for a brushless three phase motor is always quoted as Volts (rms) per Krpm, since the motor back emf is sinusoidal.

Motor iron loss

Motor iron loss is a heating effect produced in the motor laminations. It is caused by the rotating magnetic field cutting through the laminations. With the rotor shaft stationary, there is no significant iron loss. For this reason, the continuous rating of motor stall torque is greater than the continuous rating of the running torque at nominal speed.

Iron loss depends on the strength of the magnetic field and type of lamination material. As the other factors are not under user control, more significant in the Unimotor is the speed of the rotor (motor shaft). An allowance is already included in the motor data for the quoted nominal speeds.

Friction and Windage

The bearings, oil seal and air resistance to rotor speed cause internal friction. Its effect is relatively small and is included in the data provided.

Thermal Protection

An incorrect system set up can give rise to excessive motor temperatures. This can be guarded against by use of the motor thermistor protection facility.

Servo Motor/Drive system faults

Common but often unnoticed causes of motor overheating can be created by:

- Instability (self induced oscillation) within the overall servo feedback system.
- Incorrect parameter settings in the drive protection system, for example peak current, and I²T (thermal protection calculation for the drive).

Thermistor Protection

Thermistor protection devices built into the motor windings give an indication of a serious overheating problem directly at the motor windings. The thermistors do not provide an active motor cut-out, only a passive rapid increase of resistance at the temperature limit. This mechanism, when correctly connected to the appropriate circuitry of the drive, protects the class H windings of the Unimotor. Note SLM technology uses special software to protect the motor

The installer must connect the motor thermistor outputs to the electronic circuit in the drive to cause motor power shutdown in the event of gross overheating. It is the installer's responsibility to ensure that this protection facility is properly connected and set at the drive. **Failure to ensure the correct operation of the protection facility invalidates the motor warranty in respect of a burnt-out winding.**

Environment and Torque De-rating

The temperature of the environment into which the Unimotor is mounted must be considered. Unimotor optimises the effects of radiated and convected heat to the surrounding air in any mounting orientation. The greater the housing temperature above the surrounding air, the more efficient the process becomes. Note that Unimotor housing temperatures are typically 100°C maximum for class F, and 125°C maximum for class H at continuous full rating and 40°C ambient temperature.

Mounting arrangements

The Unimotor is specified in accordance with IEC and BS specifications, where the motor front flange is mounted to an aluminium plate of certain dimensions in free air at ambient temperature. See performance specifications 'Thermal conductance table'. If the motor mating surface is heated from an external source, such as a gearbox, or if the mating surface is a poor thermal conductor, then de-rate motor torque. This can be anywhere between 5% and 20%. Consult CT Dynamics if unsure.

High ambient air temperature

Assuming copper losses dominate, (2,000 and 3,000 rpm motors) the temperature rise is given by $\Delta T = k(\text{torque})^2$, where k is a constant. Hence, for an ambient temperature T°C (> 40°C max.), derate torque using the following formula as a guideline:

$$\text{New de-rated torque} = (\text{specified torque}) \times \sqrt{1 - (T - 40)/(\Delta t_w \text{max.})}$$

where $\Delta t_w \text{max}$ = winding temperature rise of
 100°C maximum for class F (encoder).
 125°C maximum for class H ratings (resolver).
 T = Ambient temperature °C

For example, for an ambient temperature of 76°C and class F:

New de-rated torque = specified torque $\sqrt{0.64}$

New de-rated torque = 0.8 x (specified torque)

Bearing Life

When selecting a motor some consideration must be made to the loading that the required application will put on the motor shaft. All shaft loads are transferred to the motor's bearing system, so a poorly selected motor could result in premature bearing failure.

The following equations are given as a guide for the estimation of a motor's bearing life in a given application. It MUST be noted that these equations do not take into account elevated ambient temperatures, shock loading or vibration. These conditions will reduce a motors bearing life and if these conditions are foreseen a more detailed study must be carried out.

Calculation of Bearing Life (Radial Loading)

The front bearing of a motor has the highest radial loading and therefore this will determine the bearing life of the motor.

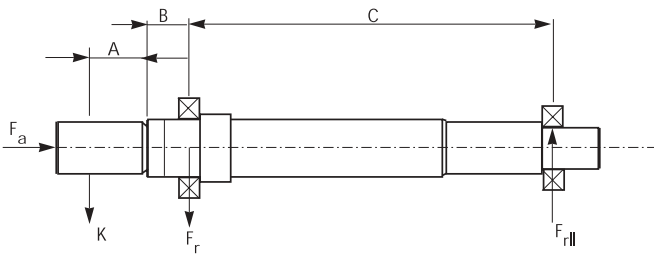

- A - Position of load to output shaft shoulder
- B - Distance from shaft shoulder to front bearing
- C - Distance between bearing centres
- K - Radial load applied to shaft output end
- Fr - Radial load on front bearing
- Fa - Axial load applied to shaft output end & front bearing
- Frll - Radial load on rear bearing

Values of 'B' and 'C' for Unimotor shafts are in Table 4.

The load applied to the shaft output end and its position will effect the radial force on the front bearing, which is calculated as follows:

EQUATION 1.
$$F_r = \frac{(A + B + C)}{C} \times K$$

The life of a bearing is dependent upon the speed of the motor; the faster the speed, the shorter the bearing life. The speed of the motor is defined in the bearing life calculation as:

f_n - Speed factor

Speed factors for the range of Unimotor speeds are given in Table 1.

Motor Speed (rpm)	Speed Factor (fn)
1000	0.322
2000	0.255
3000	0.223
4000	0.203
4500	0.195
5000	0.188
6000	0.177

Table 1 - Speed factor for given motor speeds

Calculated Bearing Life

Using the information given above, the bearing life can now be calculated using equation 2.

EQUATION 2

$$L_{10} = 500 \times \left(f_n \times \frac{C_r}{P} \right)^3$$

Normally $P = F_r$

Where:

- f_n - Speed factor
- P - Bearing Load. (Newton) For pure radial load on shaft output: $P = F_r$
- C_r - Basic load rating (Newton) (see Table 2)
- L_{10} - Bearing fatigue life (hours)

NOTE

The L_{10} life is defined as the calculated fatigue life with a statistical reliability of 90%

Motor	Basic load rating C_r (N)	Basic Static load rating C_{or} (N)	Geometry factor f_o
75UM	7650	3750	13.2
95UM	12800	6600	13.1
115UM	10100	5850	14.5
142UM	19500	11300	13.8
190UM	29100	17900	14.0

Table 2 - Basic load ratings for Unimotor

Combined Radial And Axial Loading

In some applications in addition to radial shaft loading an axial load will be applied to the output shaft. Axial loads further reduce bearing life and their effect can be calculated as follows:

The same bearing life calculations are used but a new value of 'P' must be calculated.

EQUATION 3

$$P = XF_r + YF_a$$

Where:

- P - Is now referred to as the Equivalent load
- F_r - Radial load
- F_a - Axial load
- X^a - Radial load factor
- Y - Axial load factor
- e - Deep groove ball bearing constant

Values of X and Y are determined from Table 3.

$\frac{f_0 F_a}{C_{0r}}$	e	$\frac{F_a}{F_r} \leq e$		$\frac{F_a}{F_r} > e$	
		X	Y	X	Y
0.172	0.19	1	0	0.56	2.30
0.345	0.22	1	0	0.56	1.99
0.689	0.26	1	0	0.56	1.71
1.03	0.28	1	0	0.56	1.55
1.38	0.30	1	0	0.56	1.45
2.07	0.34	1	0	0.56	1.31
3.45	0.38	1	0	0.56	1.15
5.17	0.42	1	0	0.56	1.04
6.89	0.44	1	0	0.56	1.00

Table 3 - Dynamic Equivalent Load

Motor Type	B (mm)	C (mm)
75UM	13	114
95UM	15	126
115UM	15	143
142UM	20	122
190UM	26	155

Table 4 - UM Shaft Dimensions

Note: Shaft dimensions quoted are for the shortest shaft length for each motor type, therefore bearing loads are at the maximum per frame size.

Worked Examples

Example 1

A 95UMA500CACAA motor is to be used in an application where a radial shaft load of 460 N will be applied 25.0 mm from the shaft shoulder. What will the calculated bearing life for the motor be?

i.e.

A = 25mm K = 460N

From Table 4:

B = 15mm C = 126mm

Now:

Substituting A, B, C and K into EQUATION 1

$$F_r = \frac{(A + B + C)}{C} \times K$$

$$F_r = \frac{(25 + 15 + 126)}{126} \times 460$$

$$F_r = 606.03 \text{ N}$$

Only pure radial load:

∴ P = F_r = 606.03 N

Motor speed is 5000rpm

So from Table 1

$$f_n = 0.188$$

From Table 2

$$C_r = 12,800 \text{ N}$$

Substituting C_r, P and f_n into EQUATION 2

$$L_{10} = 500 \times \left(f_n \times \frac{C_r}{P} \right)^3$$

$$L_{10} = 500 \times \left(0.188 \times \frac{12,800}{606.03} \right)^3$$

$$L_{10} = 31,303 \text{ Hours}$$

12

Example 2

It has been determined that the application in example 1 will actually apply an additional axial load to the motor shaft of 200 N. What will the calculated bearing life be reduced to?

i.e.

$$F_a = 200$$

From Table 2

$$C_{or} = 6600N \quad f_0 = 13.1$$

From example 1

$$F_r = 606.03N \quad f_n = 0.188 \quad C_r = 12,800N$$

Using Table 3

$$\frac{f_0 F_a}{C_{or}} = 0.397$$

The closest value to that for

$$\frac{C_{or}}{F_a} = 30$$

∴

$$e = 0.23$$

$$\frac{F_a}{F_r} = \frac{200}{606.03} = 0.33 > e$$

Since $\frac{F_a}{F_r} > e$

From Table 3

$$X = 0.56 \quad \text{and} \quad Y = 1.92$$

Substituting X, Y, F_r and F_a into EQUATION 3

$$P = XF_r + YF_a$$

$$P = (0.56 \times 606.03) + (1.92 \times 200)$$

$$P = 723.38N$$

Substituting C_r , P and f_n into EQUATION 2

$$L_{10} = 500 \times \left(f_n \times \frac{C_r}{P} \right)^3$$

$$L_{10} = 500 \times \left(0.188 \times \frac{12800}{723.38} \right)^3$$

$$L_{10} = 18,406 \text{ Hours}$$

Example 3

A 142UMD200CACAA motor is to be used in an application where a bearing life of 30,000 hours is required. A radial load will be applied to the shaft via a belt at a distance of 30mm from the shaft shoulder. What is the maximum force that can be applied to the shaft?

i.e.

$$L_{10} = 30,000 \quad A = 30mm$$

Motor speed is 2000rpm

∴ from Table 1 $f_n = 0.255$

From Table 2

$$C_r = 19,500 N$$

Rearranging EQUATION 2 for 'P'

$$L_{10} = 500 \times \left(f_n \times \frac{C_r}{P} \right)^3$$

$$P = f_n \times C_r \times \left(\frac{500}{L_{10}} \right)^{1/3}$$

$$P = 0.255 \times 19,500 \times \left(\frac{500}{30,000} \right)^{1/3}$$

$$P = 1,270.16 N$$

Pure radial load

$$\therefore P = F_r$$

From Table 4

$$B = 20mm \quad C = 122mm$$

Rearrange EQUATION 1 for 'K'

$$F_r = \frac{(A + B + C)}{C} \times K$$

$$K = \frac{F_r \times C}{(A + B + C)}$$

$$K = \frac{1270.16 \times 122}{(30 + 20 + 122)}$$

$$K = 900N$$

Safety

You should read this section in full before installing or using the Motors described in this manual.

Before you install or service Unimotor servomotors you should be properly trained and qualified to do so. Refer to the installation guide delivered with the motor for full installation instructions. Follow all instructions carefully.

Transportation

All servomotors have been inspected before leaving the factory and are packed in perfect condition. When you receive the motor, please check it for any external damage it may have received in transit. If you see anything wrong, write out a damage notification statement in the presence of the carrier.

Handling

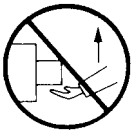

DO NOT USE COVER FOR LIFTING

Do NOT lift Unimotor by holding its encoder cover. Care should be taken when lifting the larger frame size motors, which can weigh as much as 48 kg. Use mechanical assistance where possible. The 190mm frame size motors have lifting eyes to aid handling.

Storage

Store the motor only in an enclosed, dry, ventilated and vibration-free place within temperature limits -20°C to +70°C. Any damage caused by incorrect storage or handling is not covered by the defects warranty.

Installation



DANGER High Voltage

Before you attempt any connecting or fitting operations, make sure that the voltage supply to the motor is off, and disconnect cables.

Unimotor servomotors are manufactured in accordance with IEC60072, and are sealed to IP65S. During connection care must be taken to ensure suitable sealing for cable outlets. The desired cable outlet direction can be achieved by rotation of the connector, or by 90° increments of the terminal box.

Allow sufficient room for cables/connector access. Minimum cable bend radius is numerical 10 x cable diameter.

Fixing Dimensions

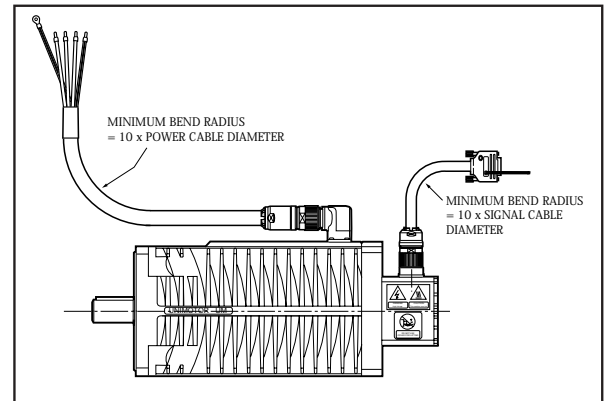

Frame Size	Fixing Hole p.c.d.	Register Ø(mm)	No. Holes	Free Holes Ø(mm)
75	75	60.0 (J6)	4	5.8 (H14)
95	100	80.0 (J6)	4	7.0 (H14)
115	115	95.0 (J6)	4	10.0 (H14)
142	165	130.0 (J6)	4	12.0 (H14)
190	215	180.0 (J6)	4	14.5 (H14)



CAUTION
The Machine Runs Hot

During operation, the motor's surface temperature may exceed 100°C. Ensure that no temperature sensitive devices touch the motor's surface. If necessary, take precautions to prevent contact.

The motor dissipates its heat through convection, radiation and by conduction via the front flange of the motor's body. The motor should be mounted so that heat dissipation is not reduced. This can be done by mounting the motor to a suitable thermally conductive mounting surface and allowing space around the motor for the free circulation of air. Ambient temperatures of between 0°C and 40°C are acceptable.

If running the motor with couplings or pulleys, ensure the output key is correctly seated.



Do NOT use a hammer to fit couplings or pulleys as you will damage the motor bearings. Fit them to the motor shaft using the shaft threads provided.

Remove output key

If you want to run the motor with no coupling fitted, then to reduce the risk of injury, remove the output key first. This may be necessary, for example, when carrying out resolver/encoder tests.

Earth bond

When fitting the motor, connect an earth bond strap from the machine to the motor body. CT Dynamics recommend that you fit the strap to the front flange of the motor in such a way that it will not interfere with mounting of the motor.

Ensure that the registration spigot is correctly located. The motor shaft should be correctly aligned with the driven load. It is inadvisable to fit a third bearing to the shaft without a suitable end coupling.

Electrical Connection



DANGER
High Voltage

Switch off the drive for at least two minutes before disconnecting, connecting or fitting the motor. See 'Installation Guides' from Control Techniques. The motor contains a permanent magnet rotor. As a result, a voltage is generated at the motor terminals when the rotor is turned. If the motor is backdriven for any reason care must be exercised to avoid electric shocks.

The motor typically operates at switching voltages of 600 - 700V DC, even when stationary. Ensure that an earth wire is correctly fitted to the motor connecting pin or earth point.

For motors with connections made via a terminal or hybrid connection box, ensure that a good seal is made between cables and the cable glands. Hybrid is denoted in the motor type number by an **H** (Hybrid) or **C** (Connector) for connection type:

142UME301 H AAAA Hybrid box	Uses a gland
142UME301 C AAAA Connectors	No glands

Please ensure that connections are made correctly. For setting up of feedback devices turn to Feedback Devices section.

Drive

You must ensure that the drive parameters are set to provide the motor with adequate thermal protection. The rating label gives the motor's stall and rated current. Refer to this label when you set the peak and rated current limit for the drive. Care should be taken to ensure PID and rated speed settings are also correct.

Drive Parameters for Unidrive

When first connecting a motor to a drive it is necessary to set the drive parameters to match the motor. The value of these parameters will vary with each motor type.

All motors are delivered with commutation correctly pre-set to match CT drives.

Do not attempt the phasing (commutation) check with motor load torque applied.

M'Ax and Multi'Ax Drive

Parameters for these drives are automatically set from E²PROM data contained within the SLM motor.

Parking Brakes

Where fitted, fail safe brakes are usually 24V DC, and are not polarity conscious. CT Dynamics recommend that you fit a reversed polarity diode across the brake coil at the relay contacts or semi-conductor drive, together with appropriate R/C (Resistor/Capacitor) noise suppression.

To release the brake, the coil must be energised. The brake can only perform a limited number of emergency braking operations: it should not normally be used for dynamic braking. See the section on Fail Safe Parking Brakes for brake information.



Do not apply the brake while the shaft is rotating except for emergency braking such as a mains supply failure.

Servicing

The only service you should perform is to clean the motor surface. The bearings in the motor are greased for life. The warranty is void if the motor is dismantled or repaired by someone other than the manufacturer or at an approved workshop. Should overspraying of the motor be desired, design data can no longer be guaranteed.

TORQUE		SI UNIT - Newton metre (Nm)
To convert from:	To:	Multiply by:
lb ft	Nm	1.356
lb in	Nm	0.1129
oz in	Nm	7.062×10^{-3}
Nm	lb ft	0.7375
Nm	lb in	8.857
Nm	oz in	141.6

MOMENT OF INERTIA		SI UNIT - kilogram metre ² (kg m ²)
To convert from:	To:	Multiply by:
lb in s ²	kg m ²	0.113
oz in s ²	kg m ²	7.06155×10^{-2}
kg m ²	lb in s ²	8.85075
kg m ²	oz in s ²	141.612
kg cm ²	kg m ²	10^{-4}

FORCE		SI UNIT - Newton (N)
To convert from:	To:	Factor:
lb(f)	N	4.4482
N	lb(f)	0.22481

LINEAR ACCELERATION		SI UNIT - metres per second ² (m/s ²)
To convert from:	To:	Factor:
in/s ²	m/s ²	2.54×10^{-2}
ft/s ²	m/s ²	0.3048
m/s ²	in/s ²	39.37
m/s ²	ft/s ²	3.2808

See also 'Performance Definitions'

Absolute feedback

With the shaft in any position at motor start, the data from an absolute feedback mechanism always relays the position of the shaft, even if the shaft turns when the feedback has no power supply. A non-absolute feedback mechanism must start from a known rotational position, such as the index pulse.

Acceleration

The rate of change of velocity. A negative value corresponds to decreasing velocity. (Deceleration).

Accuracy

A measure of the difference between an expected value and an actual value. Motor accuracy is usually given as an angle representing the maximum deviation from expected position.

Ambient temperature

The temperature of the medium, usually air, immediately surrounding the motor or other device.

Angular accuracy

The measure of shaft positioning accuracy on a servo, stepping motor or any position transducer.

Back EMF

The voltage generated when a permanent magnet rotor rotates. This voltage is directly proportional to motor speed and occurs whether the motor winding(s) are energized or unenergized.

B.EMF Harmonic Distortion

Root sum squares of the rms values of non fundamentals as a percentage of fundamental rms values.

$$\%THD = \frac{\sqrt{V_2^2 + V_3^2 + \dots + V_N^2}}{\sqrt{V_1^2 + V_2^2 + V_3^2 + \dots + V_N^2}} \times 100$$

Where terms 2...N are the voltage of the harmonics and term 1 is the voltage level of the fundamental.

Braking resistors

Required by drives for high dynamic systems.
See also Dynamic braking.

Brushless servomotor

Any servomotor that operates using electronic commutation of phase currents rather than electromechanical (brushes) commutation. Commutation is a function of rotor position. These motors typically have a permanent magnet rotor and wound stator.

CE Mark

An EC certificate indicating that the machine that carries it meets European approved standards.

Class F insulation

A NEMA insulation specification. Class F insulation is rated to an operating (internal) temperature of 155°C.

Class H insulation

A NEMA insulation specification. Class H insulation is rated to an operating (internal) temperature of 180°C.

Closed loop

Any system that measures output and compares it with input. The output is then adjusted to reach the desired condition. In motion control, this typically describes a system that uses a velocity and/or position transducer to generate correction signals.

$$\text{Cogging (Cogging torque)} = \frac{\text{peak cogging}}{\text{rated torque}} \times 100\%$$

A non-uniform angular velocity. Cogging results in jerking motion, especially at low speeds. When an armature turns slowly, rotation might not be uniform because of the tendency of the armature to favour certain angular positions.

See also Skewed Stator.

Commutation

1. The action of steering currents or voltages on the proper motor phases that result in optimum motor torque. In brush type motors, the brushes and commutator commutate electromechanically. In brushless motors, commutation is achieved by the switching electronics using rotor position information. This information is obtained from the feedback device.
2. Commutation of stepping motors is normally open loop. Feedback from the motor is not required to hold rotor position precisely.

Continuous stall current (I_{CS}) (Amps)

The amount of current applied to a motor (at locked rotor conditions) that results in rated temperature rise. See also Continuous stall torque

Continuous stall torque (T_{CS}) (Nm)

The amount of torque at zero speed which a motor can deliver constantly without exceeding its thermal rating. It is determined by applying DC current through two windings with the rotor locked, while monitoring temperature. It is specified with motor windings at maximum rated temperature, with the motor in 40°C ambient, mounted to a heat sink. See individual specifications for heat sink size.

Controller

A programmed electronics interface between the drive and the customer's system.

CSA

Canadian Standards Authority

Current at peak torque (I_{PK}) (Amps)

The amount of input current required to develop "peak torque".

Current, Rated

The maximum allowable continuous current a motor can use without exceeding motor temperature limits.

Demagnetising current

The current level at which the motor magnets start demagnetizing. The effect is irreversible and changes the motor characteristics and degrades performance.

Differential line drivers

Active electronic drivers with twin outputs, each the inverse of the other.

Differential Receiver

Receiver amplifier to match the differential driver. Noise picked up on both lines are rejected.

Direct-on-Line

A direct-on-line motor operates directly from the mains supply without driver or inverter.

Driver

An active robust electronic device capable of transmitting information down long cables.

Duty cycle

The ratio of on time to total cycle time in a repetitive cycle.
Duty cycle (%) = (On time) / (On time + Off time) x 100

Dynamic braking

A passive method of stopping a permanent magnet brushed or brushless motor. The motor windings are shorted together through a resistor so causing motor braking. Speed decreases exponentially. See also Regeneration.

Efficiency

The ratio of power output to power input.

Electrical time constant (t_e) (Seconds)

The time required for current to reach 63.2% of its final value for a fixed voltage level. It is given by: $t_e = L/R$ where L is inductance (Henries) and R is resistance (Ohms). This is more relevant for direct-on-line motors, where the delay is significant for build up torque.

Encoder

A feedback device that converts mechanical motion into electronic signals. Rotary encoders, for example, output digital pulses that correspond to incremental angular motion. The encoder consists of a glass wheel with alternating transparent and opaque stripes. Optical sensors detect the intensity to produce the digital outputs.

Explosion proof

A classification indicating that a motor can withstand internal explosions without bursting and will contain ignition within the motor frame.

Feedback

A signal transferred from the output back to the input for use in a closed loop system.

Four quadrant

A motion system that can operate in all four quadrants i.e. velocity in either direction and torque in either direction. The motor can therefore accelerate, run, and decelerate in either direction.

Friction

A resistance to motion caused by a contacting surface. Friction is either constant with varying speed (Coulomb friction) or proportional to speed (viscous friction).

Hall sensors

A feedback device in a brushless servo system that provides information for the drive to electronically commutate the motor. A magnetized wheel and Hall effect sensors may be used to generate the commutation signals.

Harmonic Distortion - see B.EMF Harmonic Distortion**Hybrid stepping motor**

A brushless motor that moves in discrete increments or steps. The motor has a permanent magnet rotor and a wound stator. Motion derives from phase currents commutated as a function of time.

Inductance (L) (Henries) (Phase-to-Phase)

The electrical equivalent of mechanical inertia. It is the property of a circuit to resist a change in current.

Inductance (mutual)

The property that exists between two current carrying conductors or coils when magnetic lines of force from one link with those of the other.

Inductance (self)

The self-inductance of a coil is the constant by which the time rate of change of the current in the coil is multiplied to give the self induced counter EMF.

Inertia (Kgm²)

The property of an object to resist change in velocity unless acted upon by an outside force. Higher inertia objects require larger torques to accelerate and decelerate. Inertia is dependent upon the mass and shape of the object.

Inertial match

For most efficient operation, the system coupling ratio should be chosen so that the reflected inertia of the load is equal to the rotor inertia of the motor.

Insulation Class

The rating assigned to the insulating components' maximum temperature capability in a motor.

Intermittent duty zone

An area of the speed torque graph in which the motor may be operated for short periods of time.

Mechanical time constant (t_m) (Seconds)

The time required in a simple first order system for the motor's speed to attain 63.2% of its final value for a fixed voltage level. It is given by:

$$t_m \text{ (secs)} = 8.87 \frac{JR}{K_T^2} \quad \text{(Not applicable to servos)}$$

where:

J is inertia in kgm^2

R is resistance in ohms

K_T is torque constant in Nm/A

Multi-turn encoder

A multi-turn encoder stores the number of rotations made by the shaft in non-volatile memory. See also Single-turn encoder.

NEMA

National Electrical Manufacturer's Association. This American organisation sets standards for motors and other industrial electrical equipment.

Neodymium-Iron-Boron (Nd-Fe-B)

A rare permanent magnet material developed in the mid 1980's. Sintered Nd-Fe-B magnet has a higher energy density than Samarium-Cobalt.

Non-volatile

Information is retained even when the power supply is removed.

Open-loop

A system in which there is no feedback. Motor motion is expected to follow the input command, but will be dependent upon the gain of the open loop series elements.

Output key

A key at the output end of the shaft that enables connection to a compatible machine. For CTD motors the key is IEC 60072 part I compatible.

Peak torque

The maximum torque that a permanent magnet motor can deliver for short periods of time. If motor peak torque is exceeded, permanent degradation of the motor magnets may result. The maximum peak torque is determined by the peak current limit which is a function of the drive.

Power

The rate at which work is done, measured in Watts.

For motion control:-

(Linear) Power = Force(N) x metres/s

(Rotational) = torque (Nm) x radians/s

(Electrical) = Amps x Volts

PTC

Positive temperature coefficient

Pull-out torque

The maximum friction load, at a given inertial load, that can be applied to the shaft of a constant speed synchronous motor without causing the motor to lose synchronism.

Pulse Width Modulation (PWM)

1. A PWM amplifier switches the output between the positive and negative supply rails of the DC supply at a fixed frequency. The duration of the on/off (mark/space) is variable. 2. Pulse Width Modulation (PWM) is a switched-mode control method used in amplifiers and drives to control motor voltage and current. By modulation of the pulse width at high frequency switching rates, lower frequencies of any waveshape can be generated.

Radian

A measure of angular distance, defined as the plane angle between two radii of a circle, which cut off a circumference arc equal in length to the radius.

2π radians = 1 rev

RDC

Resolver-to-Digital Converter. An electronic component that converts the analogue signals from a resolver into a digital word representing angular position. R to D (Resolver to Digital) is sometimes used.

Regeneration (or deceleration, or when the load turns the motor)

During motor braking, the action in which the motor acts as a generator. It takes kinetic energy or potential energy from the load, converts it to electrical energy, and returns it to the drive where it may be stored as an increased voltage charge in the d.c. capacitors. Excessive voltage must be reduced by reduction of the capacitive charge by dissipating power into brake dump resistors or to share excessive energy with other drivers by paralleling to other drive d.c. link voltages.

Repeatability

The degree to which a parameter such as velocity or position can be duplicated.

Resistance, Hot (R_H) (Ohms) (Phase-to-Phase).

The terminal resistance value of the motor, specified at the hot winding temperature, which is at the motor's maximum rated temperature.

Resolution

The smallest increment into which a parameter can be broken down. For example, a 4096 line encoder has a resolution of:

$$\frac{1}{4096 \times 4} = \frac{1}{16384}$$

Resolver

An electromagnetic feedback device that converts angular shaft position into analogue signals. These signals can be processed with an RDC to produce digital position information. Resolvers are of two basic types; transformer and transmitter. A transformer-type is designed for stator primary excitations and rotor secondary output. Position is determined by the phase shift between the rotor output signal and one of the primary excitation signals. A transmitter-type typically used in servo systems has rotor primary excitation and stator secondary outputs. Position is determined by the ratio of the cosine output amplitude to sine output amplitude.

Resonance

The oscillatory behaviour arising from excitation of a structure or system at its natural frequency.

RMS Current

Root Mean Square Current. In an intermittent duty cycle application, the RMS Current is the equivalent value of a steady state current which would produce the same motor heating over a period of time.

RMS Torque

Root Mean Square Torque. In an intermittent duty cycle application, the RMS Torque equals the value of steady state torque which would produce the same motor heating over a period of time.

Rotational velocity (rad/s)

The rate of change of rotary position, measured in radians/s.

Samarium cobalt

A type of rare-earth permanent magnet material.

Servo Mode

The normal setting used by drivers for servo motors, where feedback is basically position information, from which speed and acceleration may be derived.

Settling time

The time required for a parameter with damped oscillations or ringing and reach its final value.

Single-turn encoder

A single-turn encoder is not equipped to count and retain the number of turns completed. See also Multi-turn encoder.

Skewed Stator

In order to reduce cogging effects to near zero, the stack of laminations that form the stator is deliberately twisted or skewed by 1 slot pitch after winding insertion.

Skewed Magnets

An alternative to skewed stator for minimal cogging.

Slew

In motion control, the portion of a move made at a constant non-zero velocity.

Speed

The linear or rotational velocity of an object in motion.

Stall Torque (Locked Rotor Torque)

The amount of torque developed with voltage applied and shaft locked, or not rotating.

Step angle

The angular distance the shaft rotates when it receives a single step command.

Stiffness

The resistance to movement induced by an applied torque. Stiffness may be described by a torque displacement curve that shows the amount a motor shaft will rotate upon application of a known external force when stopped.

Synchronism

A motor rotating at a speed corresponding correctly to the applied step pulse frequency. Load torques in excess of the motor's capacity (rated torque) cause a loss of synchronism. A stepping motor is not damaged by loss of synchronism.

Tachometer

An electromagnetic feedback transducer which produced an analogue voltage signal proportional to rotational velocity. Tachometers can be either brushed or brushless.

TEFC

Totally Enclosed Fan Cooled. A type of motor enclosure.

TENV

Totally Enclosed Non-Ventilated. A type of motor enclosure.

Thermal resistance (R_{TH}) ($^{\circ}C/Watt$)

A measure of the effectiveness with which a unit gets rid of heat, given as temperature rise per Watts lost.

Thermal time constant (T_{TH}) (minutes)

The time required for a motor to attain 63.2% of its final temperature for a fixed power input.

Torque

A measure of the angular force that produces rotation. This force is defined by a linear force multiplied by a radius.

Torque is given by:

$$\text{Torque (N)} = \text{Force} \times \text{moment (m)}$$

Torque Constant ($K_T = \text{Nm/A}_{\text{rms}}$)

Expresses the relationship between input current and output torque. For each ampère of current, a fixed amount of torque results. K_T may vary with the distortion and phase error of the drive and will also reduce with temperature. In closed loop systems this compensated by the feedback.

Torque Mode

An open loop current mode for a servo drive, giving a motor torque output proportional to an input demand. Current will be controlled by the drive, but torque value will be dependent upon the K_T value for the motor which may vary with temperature.

Torque-to-inertia ratio

The motor's holding torque divided by the inertia J of its rotor. The larger the ratio, the higher a motor's maximum acceleration capability will be.

$$\text{Torque} = J \alpha \quad \text{Where } \alpha = \frac{\text{acceleration}}{\text{rads/s}^2}$$

UL

Underwriters Laboratory

Velocity

The change in position as a function of time. Velocity has both a magnitude and sign.

Viscous Damping (K_{DV}) (Nm/krpm)

All motors have inherent losses that result in a lower power delivered at the output shaft than that supplied to the machine. Losses proportional to speed (i.e. speed dependent terms such as windage, friction, eddy current) are related through the motor's "viscous damping" constant, measured as the slope of the damping curve.

Volatile

Stored information will be lost when power is removed.

Voltage constant (K_E) (Vrms/krpm phase to phase)

An operating motor generates a voltage proportional to speed but opposing the applied voltage. The shape of the voltage waveform depends upon the specific motor design. For example, brushless motors have a trapezoidal, or sinusoidal waveform. For sinusoidal motors, the voltage constant can be measured from phase-to-phase at a known speed and expressed as the back-EMF constant (K_E) Vrms/krpm.